



GB

Air/water heat pumps, heating only, with domestic hot water production, axial-flow fans and water pump assembly.

BRAN 0011M H
BRAN 0025M H
BRAN 0041M H

r HFC
R-410A

DeLonghi

Professional

U I A	General warnings	3	I A	Operating characteristics	16
U I A	Waiver of liability	3	I A	General technical data	21
U I A	Fundamental safety rules	3	A	Checking and starting up the unit	23
I A	Receiving and handling the product	4	A	HSW11 functions	24
I A	Description of standard unit	5	A	LEDs and display	25
I	Dimensioned drawings	6	I A	Displaying alarms	37
I	Installation	6	A	Shutting down for long periods	38
I A	Water connections	7	A	Routine maintenance	39
I A	Water circuit data	9	A	Special maintenance	39
I A	Operating diagrams	10	A	Disposal	39
I A	Electrical connections	12	I A	Troubleshooting	40
I A	Mains power supply connections	13			
I A	Installer connections	14			

The following symbols are used in this publication and inside the unit:



User



Important



Danger high temperatures



Installer



Prohibition



Assistance



Danger voltage

The manufacturer reserves the right to modify the data in this manual without warning.

⚠ **These appliances have been designed** to chill and/or heat water and must be used in applications compatible with their performance characteristics; these appliances are designed for residential or similar applications.

Incorrect installation, regulation and maintenance or improper use absolve the **manufacturer** from all liability, whether contractual or otherwise, for damage to people, animals or things.

Only those applications specifically indicated in this list are permitted

Read this manual carefully. All work must be carried out by qualified personnel in conformity with legislation in force in the country concerned.

The warranty is void if the above instructions are not respected and if the unit is started up for the first time without the presence of personnel authorised by the Company (where specified in the supply contract) who should draw up a "start-up" report.

The documents supplied with the unit must be consigned to the owner who should keep them carefully for future consultation in the event of maintenance or service. All repair or maintenance work must be carried out by the Company's Technical Service or qualified personnel following the instructions in this manual.

The air-conditioner must under no circumstances be modified or tampered with as this may create situations of risk. Failure to observe this condition absolves the manufacturer of all liability for resulting damage.

WAIVER OF LIABILITY

This publication is the sole property of **manufacturer**. Any reproduction or disclosure of such is strictly prohibited without the written authorisation of **manufacturer**.

This document has been prepared with maximum care and attention paid to the content shown. Nonetheless, **manufacturer** waives all liability deriving from the use of such document.

Read this document carefully. All work must be performed, components selected and materials used in complete accordance with the legislation in force in material in the country concerned, and considering the operating conditions and intended uses of the system, by qualified personnel.

FUNDAMENTAL SAFETY RULES

When operating equipment involving the use of electricity and water, a number of fundamental safety rules must be observed, namely:

⊗ **The unit must not be used** by children or by unfit persons without suitable supervision.

Do not touch the unit with bare feet or with wet or damp parts of the body.

Never perform any cleaning operations before having disconnected the unit from the mains power supply.

Do not modify safety or control devices without authorisation and instructions from the manufacturer.

Do not pull, detach or twist the electrical cables coming from the unit, even when disconnected from the mains electricity supply.

Do not open doors or panels providing access to the internal parts of the unit without first ensuring that the switch QF1 is in the OFF position (see the wiring diagram).

Do not introduce pointed objects through the air intake and outlet grills.

Do not dispose of, abandon or leave within reach of children packaging materials (cardboard, staples, plastic bags, etc.) as they may represent a hazard.

⚠ **Respect safety distances** between the unit and other equipment or structures. Guarantee adequate space for access to the unit for maintenance and/or service operations.

Power supply: the cross section of the electrical cables must be adequate for the power of the unit and the power supply voltage must correspond with the value indicated on the respective units. All units must be earthed in conformity with legislation in force in the country concerned.

Terminals 6, 7, 8 & 9 may be live even after the unit is disconnected. Make sure power is not connected before proceeding.

Water connections should be carried out as indicated in the instructions to guarantee correct operation of the unit. Add glycol to the water circuit if the unit is not used during the winter or the circuit is not emptied.

Handle the unit with the utmost care (see weight distribution table) to avoid damage..

When the items are consigned by the carrier, check that the packaging and the unit are undamaged.

If damage or missing components are noted, indicate this on the delivery note. A formal complaint should be sent via fax or registered post to the After Sales Department within eight days from the date of receipt of the items.

The units are supplied complete with:

- instruction manual;
- guarantee certificate;
- CE declaration;
- list of the main components and sub-assemblies fitted on the product. These are contained in a plastic bag (A) attached to the top of the chiller.

The unit must be handled by qualified and suitably equipped personnel only using equipment appropriate for the weight of the unit, in compliance with the safety standards in force (and subsequent amendments.).

If a forklift truck is used, insert the forks under the base, spacing the forks as wide apart as possible.

If a crane is used, pass the cables through the bottom of the base, making sure they do not exert pressure on the unit.

Once the packaging has been removed, the appliance can be lifted and moved by inserting two metal tubes (max. diameter 22 mm) into the feet, and using suitable handling equipment.

⚠ The instruction manual is an integral part of the unit and should therefore be read and kept carefully..

The packaging should not be removed until the unit is located in the installation site.

⊗ Do not dispose of packaging materials in the environment or leave them within reach of children as they may represent a hazard.

⚠ The weight of the unit is biased towards the compressor side (side of the packaging with the bar code, see the figure).

During transport, the unit should be kept in a vertical position.

The unit must be stored sheltered from direct sunlight, rain, wind or sand.

Avoid exposing the unit to direct sunlight, as the pressure inside the refrigerant circuit may reach dangerous values and cause the activation of the safety valves, where fitted.

Check the instructions on the packaging for stacking units.

The packaging must be removed by the operator using suitable protective equipment (gloves, glasses, etc.). Take special care not to damage the unit.

Observe the local standards in force as regards disposal of the packaging, using specialist collection or recycling centres.

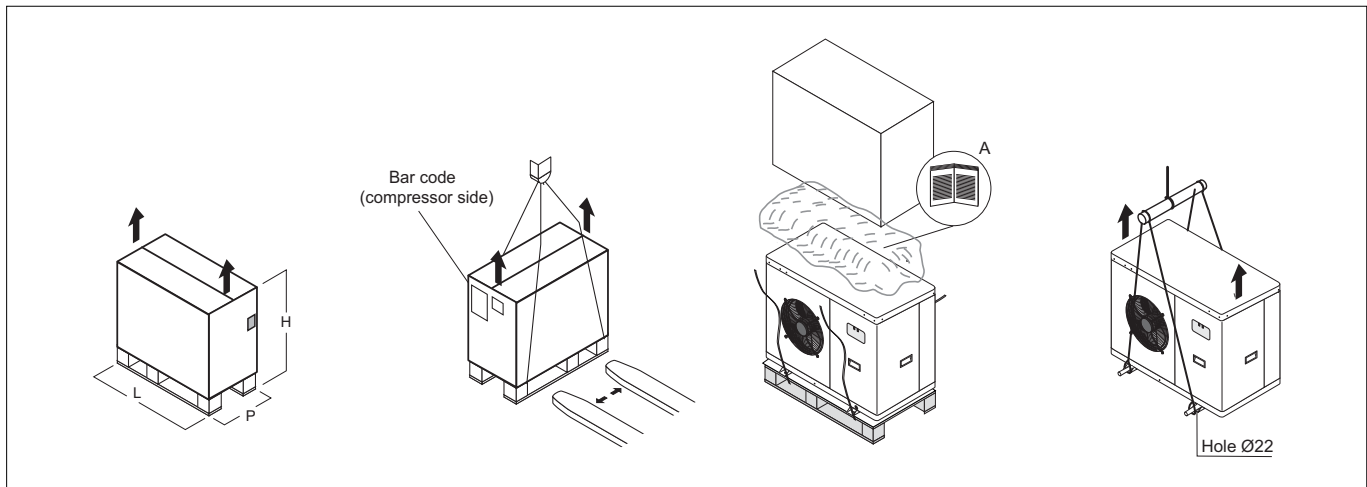

Dimensions		0011	0025	0041
Dimension L	mm	950	950	950
Dimension P	mm	450	450	450
Dimension H	mm	650	950	1250
Gross weight	kg	105	130	160

These air/water heat pump with axial-flow fans operate with R410A refrigerant fluid and are suitable for outdoor installation. The units are CE marked, as established by the EU directives, including the latest amendments, and the corresponding approximated national legislation.

They are factory tested and on site installation is limited to water and electrical connections.

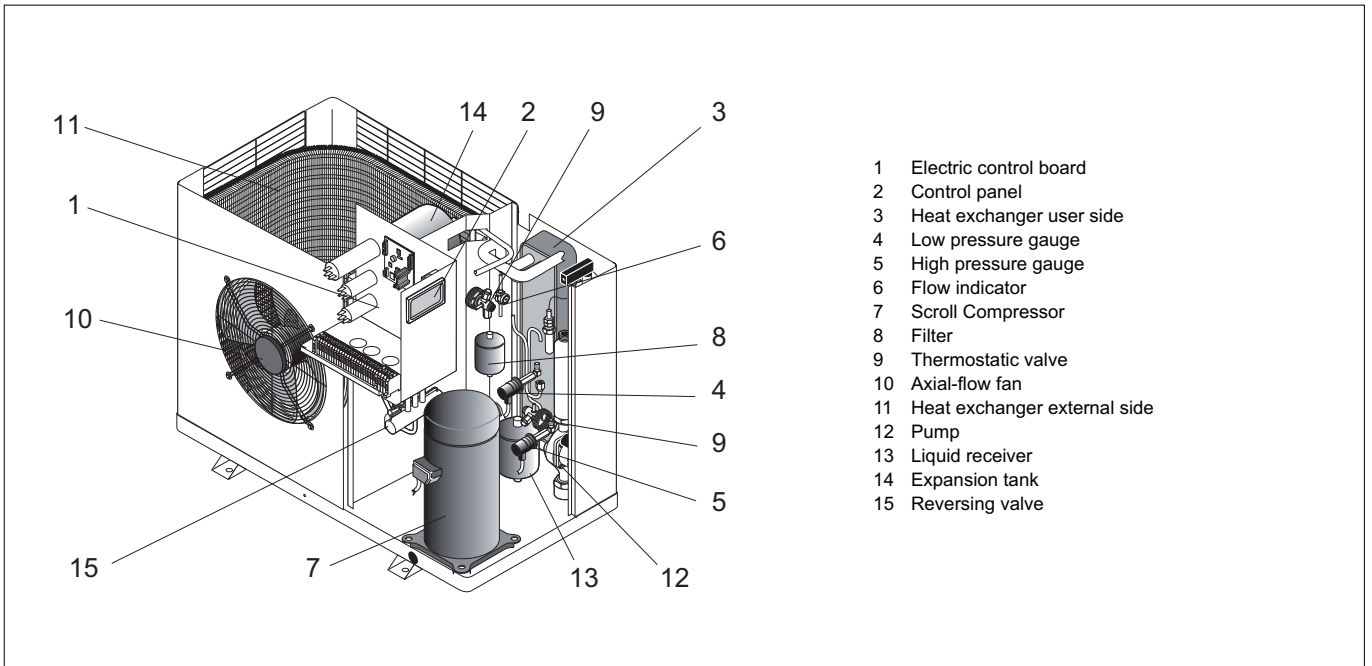

VERSIONS AVAILABLE



BRAN H

Air/water heat pump, heating only, with domestic hot water production. Built-in water pump assembly complete with electric heaters.

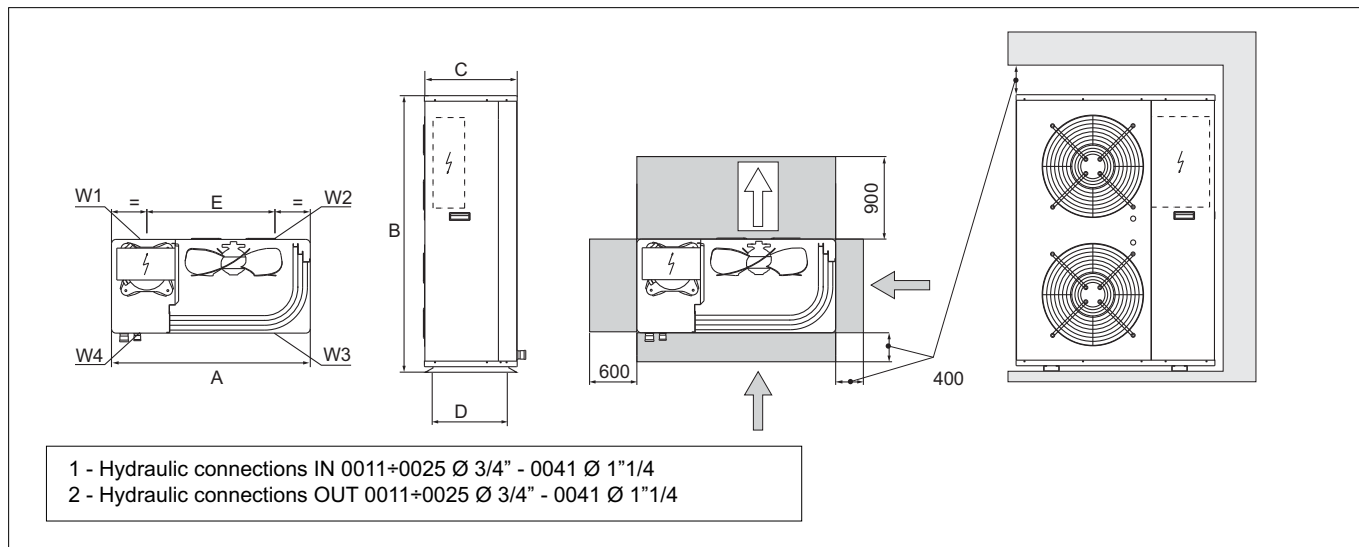

Dimensions		0011	0025	0041
A	mm	900	900	900
B	mm	640	940	1240
C	mm	370	370	370
D	mm	320	320	320
E	mm	580	580	580

Weight distribution		0011	0025	0041
W1	kg	37	45	55
W2	kg	13	16	20
W3	kg	12	15	18
W4	kg	32	39	48
tot	kg	95	115	140

INSTALLATION

CHOICE OF INSTALLATION SITE

Before installing the unit, agree with the customer the site where it will be installed, taking the following points into consideration:

- Check that the fixing points are adequate to support the weight of the unit;
- Pay scrupulous respect to safety distances between the unit and other equipment or structures to ensure that air entering the unit and discharged by the fans is free to circulate.
- Follow the instructions shown in the chapter on DIMENSIONAL DRAWINGS to allow room for maintenance operations. If installing multiple units the clearances must be doubled.

POSITIONING

Before handling the unit, check the capacity of the lift equipment used, respecting the instructions on the packaging.

To move the unit horizontally, make appropriate use of a lift truck or similar, bearing in mind the weight distribution of the unit.

To lift the unit, insert tubes long enough to allow positioning of the lifting slings and safety pins in the special holes in the base of the unit.

To avoid the slings damaging the unit, place protection between the slings and the unit.

The unit should be installed on special vibration dampers. See the chapter on DIMENSIONAL DRAWINGS for the support positions identified by W1, W2 etc. and the corresponding weights for the correct sizing of the vibration dampers.

Fix the unit, making sure it is level and that there is easy access to water and electrical components.

If the site is exposed to strong winds, fix the unit adequately using tie rods if necessary.

In heating mode the unit produces a significant quantity of condensate, which must be suitably drained.

Condensate drainage must not cause problems to objects or people.

If the outside air temperature is less than 0°C, the condensate may freeze; in these case fit a frost protection heater on the drain line.

For correct operation of the unit, avoid the following: obstacles to air flow, leaves that may block the heat exchange coil, strong winds that stop or reinforce air flow, sources of heat too close to the unit, recirculation or stratification of air.

The choice and installation of components is the responsibility of the installer who should follow good working practice and current legislation. Before connecting the pipes, make sure they do not contain stones, sand, rust, dross or other foreign bodies which might damage the unit. Construction of a bypass is recommended to enable the pipes to be washed through without having to disconnect the unit (see drain valves). The connection piping should be supported in such a way as to avoid it weighing on the unit. The following components should be installed in the water circuit:

1. Two pressure gauges with a suitable scale (intake and outlet);
2. Two vibration damper joints (intake and outlet);
3. Two shut off valves (normal in intake and calibrating in outlet);
4. **A flow switch (inlet). The flow switch must be calibrated by the installer to a value equal to 70% of rated flow.**
5. Two thermometers (intake and outlet);
6. **An intake filter must be installed as close as possible to the evaporator and positioned to allow easy access for routine maintenance.**
7. All the pipes must be insulated with suitable material to prevent the formation of condensate and heat loss. The insulating material must be a vapour barrier. Make sure that the control and shut off devices protrude from the insulation.
8. At the lowest points in the system, install drain valves for easy emptying.
9. At the highest points in the system, install automatic or manual air vent valves.
10. The unit is fitted as standard with an expansion vessel; make sure this is correctly sized for the water content of the system and the expected operating temperature, otherwise install an additional expansion vessel.

Failure to install the flow switches will mean the heat exchangers are not protected in the event of no flow of liquid. Manufacturer cannot be held liable for any damage to the unit and/or the system following the failure to install these devices or the filter.

The correct operation of the components that help ensure the safety of the appliance and the system should be checked regularly.

Specifically, this involves cleaning the filters and checking the operation of the flow switches installed.

Make sure that the frost protection heaters on the heat exchanger are powered when the unit is off (unit in standby "StbY")

Water flow to the chiller unit must conform to the values shown in the section on "General Technical Data".

The flow of water must be maintained constant during operation.

The water content of the unit must be such as to avoid disturbing operation of the refrigerant circuits.

The unit must be prevented from freezing at outside air temperatures around 0°C.

It is recommended to use suitable percentages of antifreeze (see "Water circuit data"), protect the piping with heating sheaths, and empty the system, making sure there no water remains at the lowest points in the circuit.

It is recommended to use non-toxic food grade antifreeze, compliant with the standards in force in the countries where the unit is used, if domestic hot water production is also featured.

Utility water circuit connection diagram

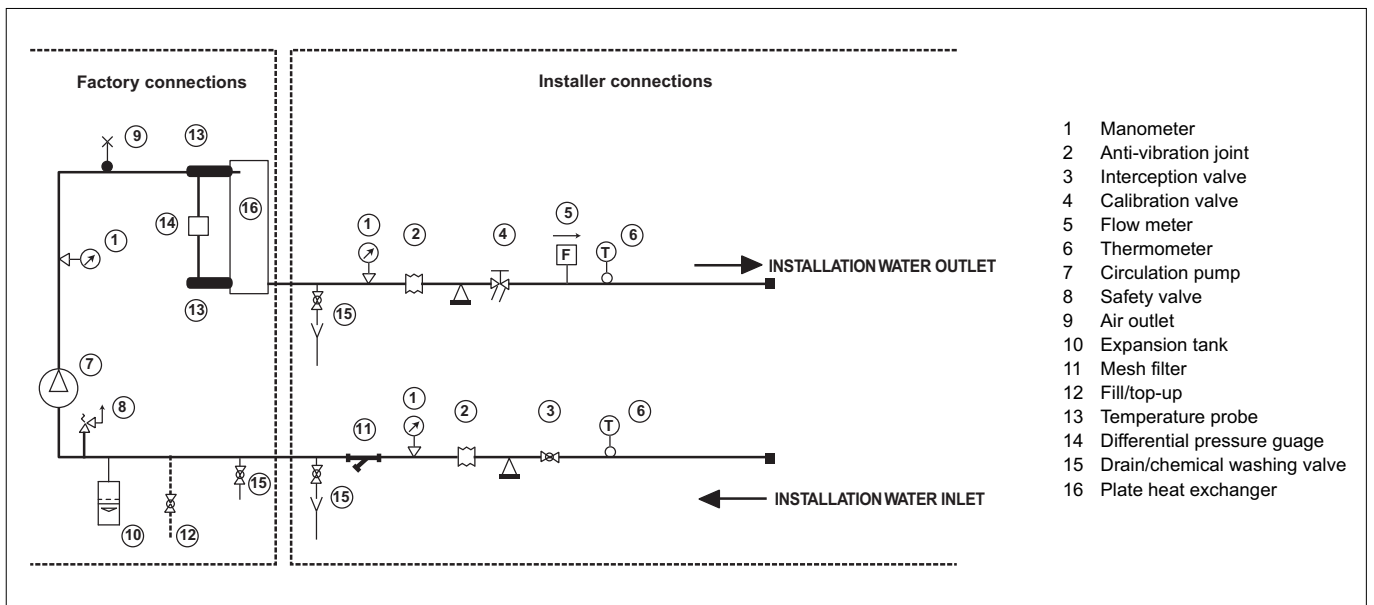

⚠ **The heat pumps** must be fitted with a filling/top-up system connected to the return line and a drain valve in the lowest part of the system.

Systems containing antifreeze or covered by specific legislation must be fitted with low-loss headers.

⚠ The manufacturer is not liable for obstruction, breakage or noise resulting from the **failure to install filters** or vibration dampers.

Particular types of **water used for filling or topping up** must be treated with appropriate treatment systems.

For reference values, see the table.

PH	6-8
Electrical conductivity	less than 200 mV/cm (25°C)
Chlorine ions	less than 50 ppm
Sulphuric acid ions	less than 50 ppm
Total iron	less than 0.3 ppm
Alkalinity M	less than 50 ppm
Total hardness	less than 50 ppm
Sulphur ions	none
Ammonia ions	none
Silicon ions	less than 30 ppm

CONDENSATE DRAIN

The unit is fitted with condensate pan; this must be connected to a drain system to take away the water that forms, see the drawing.

If the outside air temperature is less than 0°C, the condensate drained from the collection pan may freeze.

The unit must be supported on a suitable structure or brackets to keep it off the ground, with a frost protection heater fitted on the drain line.

Size and position of connections	0011	0025	0041
A (mm)	50	65	65
B (mm)	285	465	670
C (mm)	158	65	65
D (mm)	135	415	520
Hydraulic connections (Ø)	3/4"	3/4"	1"1/4"

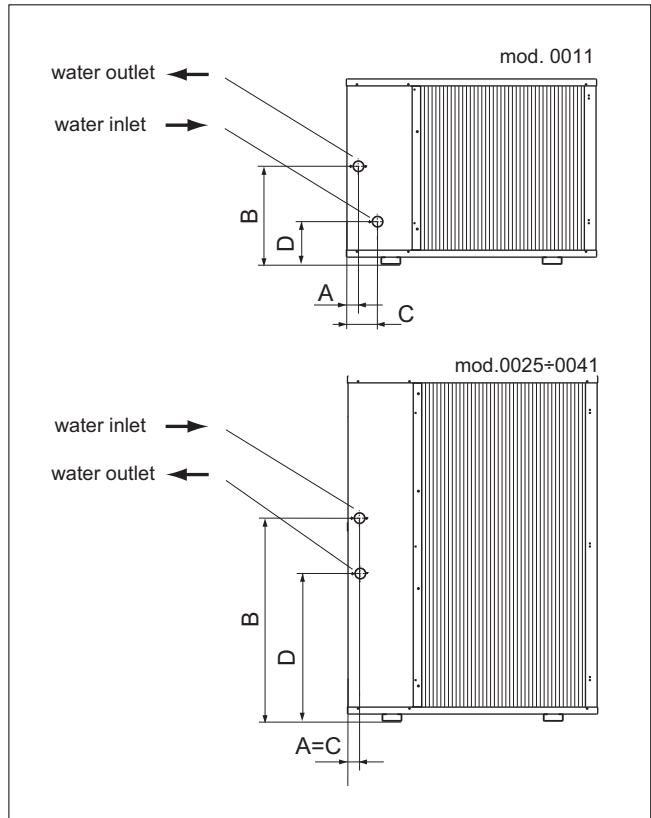

FILLING THE SYSTEM

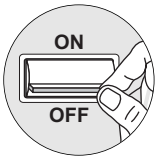

- Before starting to fill, place the unit mains switch QF1 in the OFF position.
- Before filling, check that the system drain valve is closed.
- Open all system and terminal air vents.
- Open system shut off valves.
- Start filling by slowly opening the system water fill valve outside the unit.
- When water begins to leak out of the terminal air vent valves, close them and continue filling until the pressure gauge indicates a pressure of 1.5 bar.

⚠ **The system must be filled** to a pressure of between 1 and 2 bars.

It is recommended that this operation be repeated after the unit has been operating for a number of hours. The pressure in the system should be checked regularly and if it drops below 1 bar, the water content should be topped-up.

Check the tightness of the joints.

EMPTYING THE SYSTEM

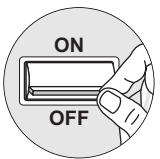

- Before starting to empty, place switch QF1 in the "OFF" position
- Make sure the system fill/top-up water valve is closed.
- Open the drain valve outside the unit and all the installation and terminal air vent valves..

⚠ If the fluid in the **circuit contains antifreeze**, it should not be allowed to drain freely, as it is pollutant.

It should be collected for possible reuse.

When draining after heat pump operation, take care as the water may be hot (up to 50°).

Water content in the system

Size		0011	0025	0041
Minimum water content	l	24	32	40

Ethylene glycol solutions

Water and ethylene glycol solutions used as a heat carrier in the place of water reduce the performance of the unit. Multiply the performance figures by the values given in the following table.

Freezing point (°C)						
	0	-5	-10	-15	-20	-25

Percentage of ethylene glycol in weight						
	0	12%	20%	28%	35%	40%
cPf	1	0,985	0,98	0,974	0,97	0,965
cQ	1	1,02	1,04	1,075	1,11	1,14
cdp	1	1,07	1,11	1,18	1,22	1,24

cPf: capacity correction factor
 cQ: flow rate correction factor
 cdp: pressure drop correction factor

Fouling factors

The performance data given refer to conditions with clean evaporator plates (fouling factor=1). For different fouling factors, multiply the figures in the performance tables by the coefficient given in the following table.

Fouling factors (m ² °C/W)	Evaporator		
	f1	fk1	fx1
4,4 x 10 ⁻⁵	-	-	-
0,86 x 10 ⁻⁴	0,96	0,99	0,99
1,72 x 10 ⁻⁴	0,93	0,98	0,98

f1: capacity correction factor
 fk1: compressor power input correction factor
 fx1: total power input correction factor

PUMP USEFUL HEAD CURVE (*)

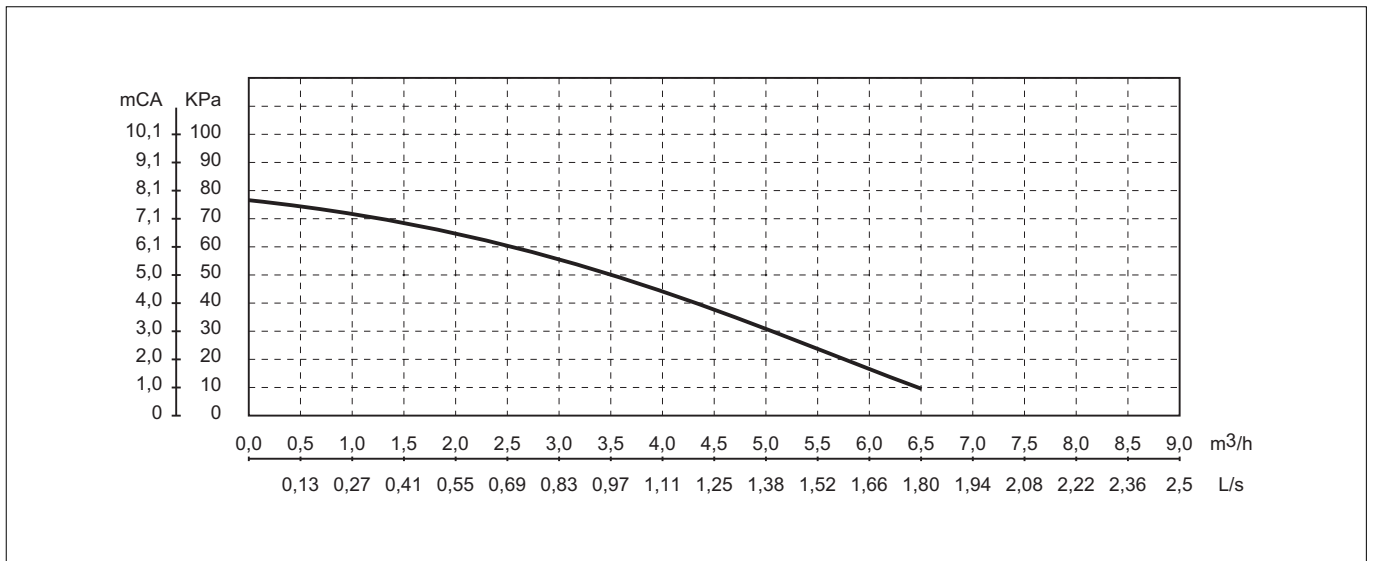

(*) To obtain the useful head of the installation, subtract the pressure drop of the plate heat exchanger.

HEAT EXCHANGER PRESSURE DROP (WATER SIDE)

Model	Water flow	m³/h	0,8	1,0	1,1	1,8	2,2	2,3	2,5	3,0	3,3
			l/sec	0,223	0,278	0,306	0,501	0,612	0,640	0,696	0,835
0011	Pressure drop	kPa	17	26	31	84	126	138	-	-	-
0025		kPa	8	12	15	39	58	63	75	-	-
0041		kPa	-	6	8	21	31	34	40	57	69

Note: the values highlighted refer to the rated flow: external air 35°C - evaporator water 12/7°C

The heat pump is connected directly to the central heating circuit (the minimum water content required must be ensured).

The heat pump can also produce domestic hot water by managing a special 3-way valve, connected to a hot water storage cylinder

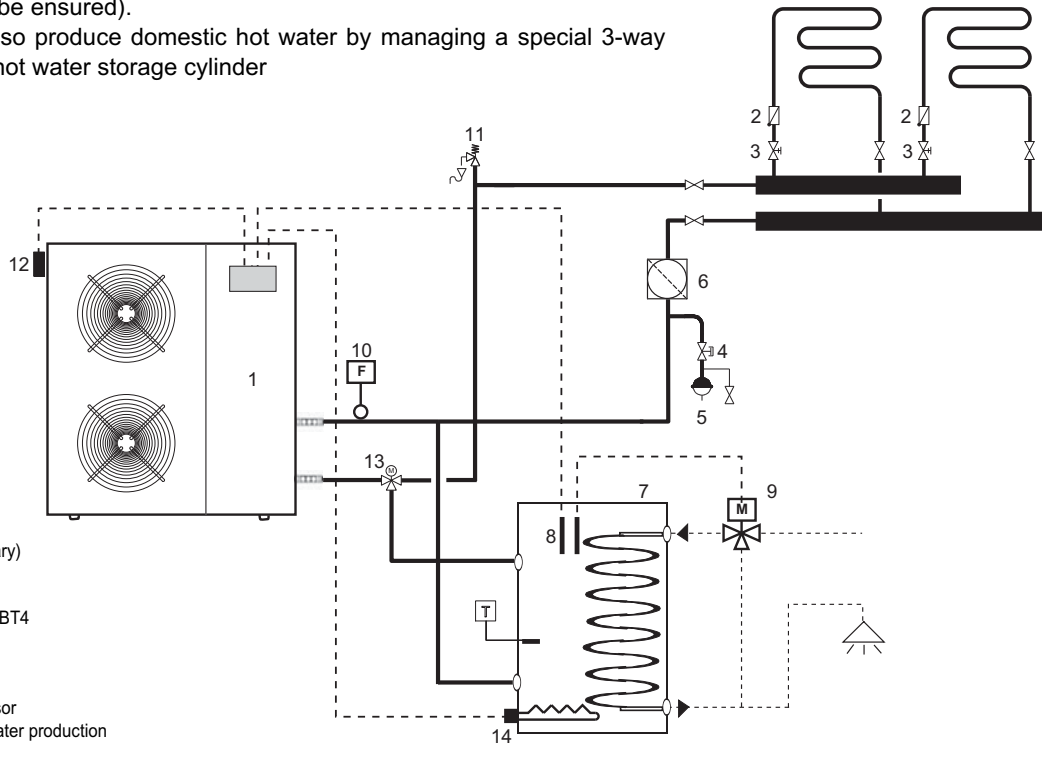

- 1 Heat pump
- 2 Non-return valve
- 3 Control valve with dial
- 4 Shut off valve
- 5 Expansion vessel (if necessary)
- 6 Air separator
- 7 DHW storage
- 8 Storage temperature sensor BT4
- 9 Thermostatic valve
- 10 Flow switch
- 11 Safety valve
- 12 Outside air temperature sensor
- 13 3-way valve, domestic hot water production
- 14 Electric heater

Example water circuit diagram

The heat pump heats the water in the heating system storage cylinder.

The underfloor system is managed by the central heating pump, installed externally to the storage cylinder, and by the mixer valve (unit 12).

The heat pump can also produce domestic hot water by managing a special 3-way valve, connected to a hot water storage cylinder.

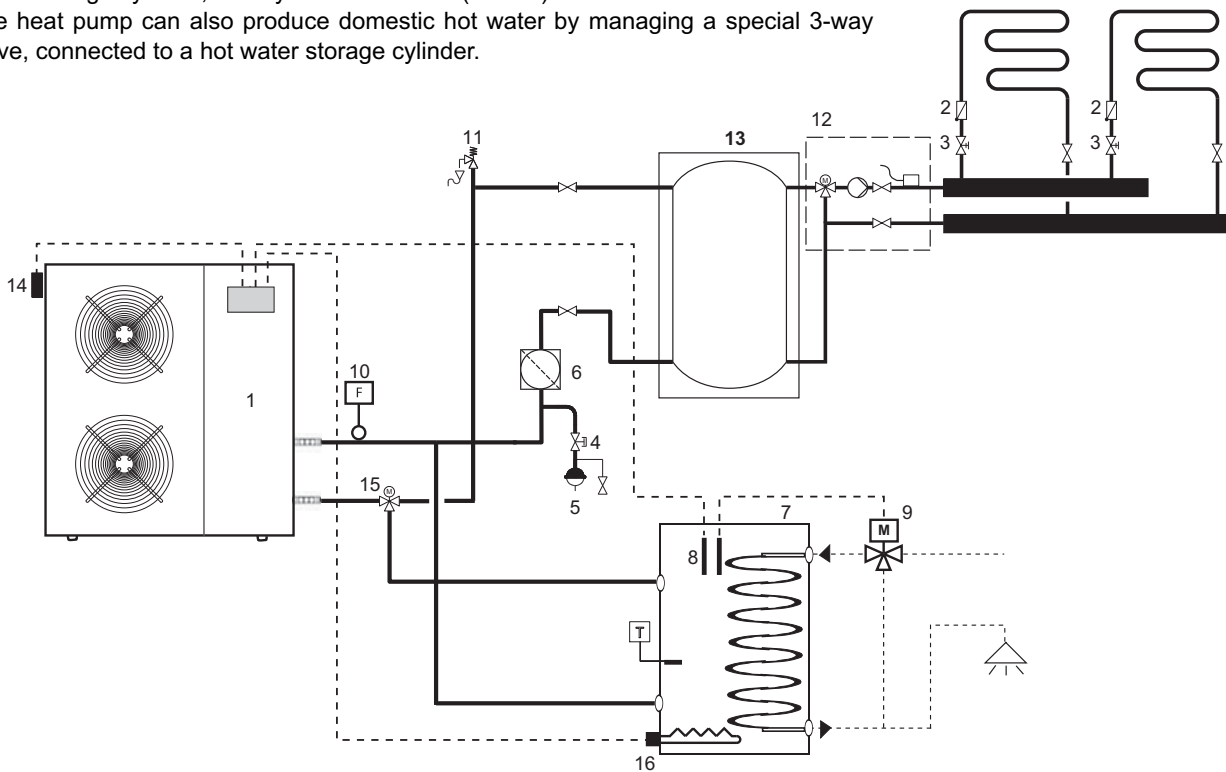

- 1 Heat pump
- 2 Non-return valve
- 3 Control valve with dial
- 4 Shut off valve
- 5 Expansion vessel (if necessary)
- 6 Air separator
- 7 DHW storage
- 8 Storage temperature sensor BT4
- 9 Thermostatic valve
- 10 Flow switch
- 11 Safety valve
- 12 Underfloor system control not supplied
- 13 System storage
- 14 Outside air temperature sensor
- 15 3-way valve, domestic hot water production
- 16 Electric heater

Example water circuit diagram

The heat pump is connected directly to the central heating circuit (the minimum water content required must be ensured).
 The heat pump can also produce domestic hot water by managing a special 3-way valve, connected to a hot water storage cylinder.

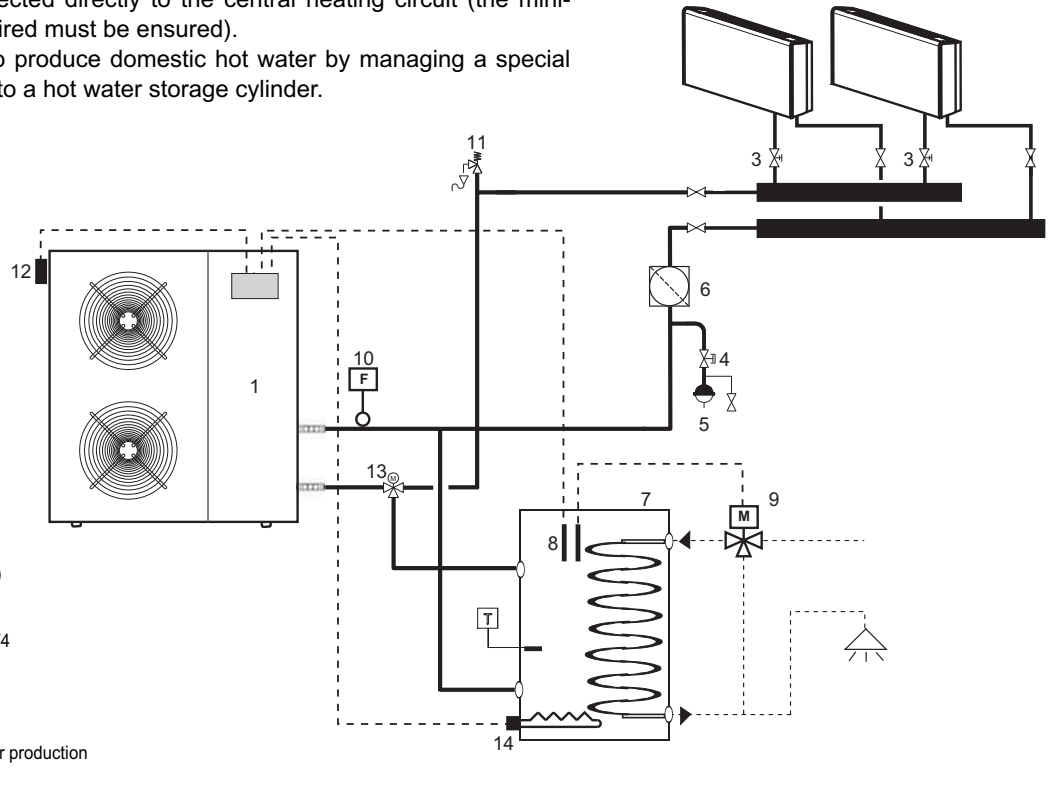

- 1 Heat pump
- 2 Non-return valve
- 3 Control valve with dial
- 4 Shut off valve
- 5 Expansion vessel (if necessary)
- 6 Air separator
- 7 DHW storage
- 8 Storage temperature sensor BT4
- 9 Thermostatic valve
- 10 Flow switch
- 11 Safety valve
- 12 Outside air temperature sensor
- 13 3-way valve, domestic hot water production
- 14 Electric heater

Example water circuit diagram

The heat pump heats the water in the heating system storage cylinder.
 The underfloor system is managed by the central heating pump, installed externally to the storage cylinder, and by the mixer valve (unit 12).
 The heat pump can also produce domestic hot water by managing a special 3-way valve, connected to a hot water storage cylinder.

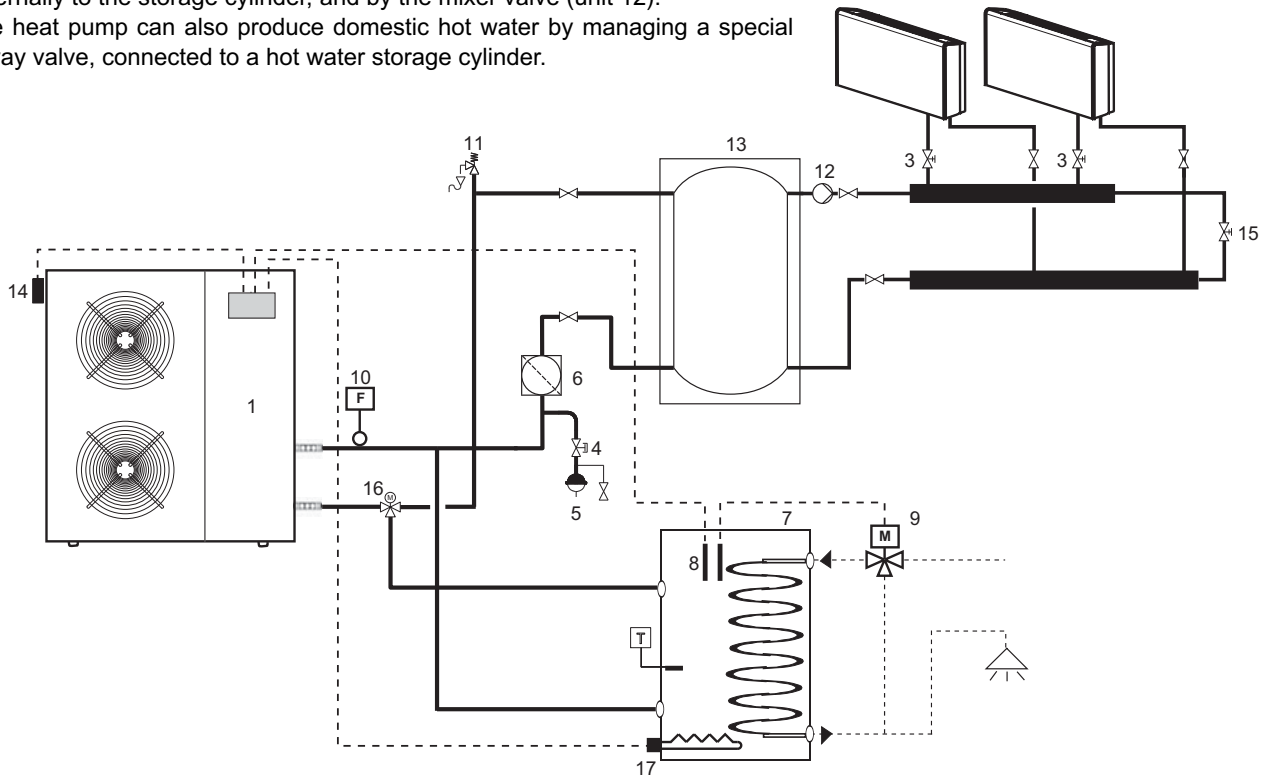

- 1 Heat pump
- 2 Non-return valve
- 3 Control valve with dial
- 4 Shut off valve
- 5 Expansion vessel (if necessary)
- 6 Air separator
- 7 DHW 3storage
- 8 Storage temperature sensor BT4
- 9 Thermostatic valve
- 10 Flow switch
- 11 Safety valve
- 12 Underfloor system control not supplied
- 13 System storage
- 14 Outside air temperature sensor
- 15 Bypass valve
- 16 3-way valve, domestic hot water production
- 17 Electric heater

Example water circuit diagram

The heat pumps must be installed downstream of a main switch (QF1, see wiring diagram), as required by the standards in force in the country where the unit is installed. Connection to the mains power supply and the connection of the flow switch to the corresponding terminals must be performed by authorised personnel in compliance with the standards in force.

For all electrical work, refer to the electrical wiring diagrams in this manual.

It is also recommended to check that:

- The characteristics of the mains electricity supply are adequate for the power ratings indicated in the electrical specifications below, also bearing in mind the possible use of other equipment at the same time.

⚠ Power to the unit must be turned on only after installation work (plumbing and electrical) has been completed.

All electrical connections must be carried out by qualified personnel in accordance with legislation in force in the country concerned

Respect instructions for connecting phase, neutral and earth conductors..

The power line should be fitted upstream with a suitable device to protect against short-circuits and leakage to earth, isolating the installation from other equipment.

⚠ Voltage must be within a tolerance of $\pm 10\%$ of the rated power supply voltage for the unit (for three phase units, the unbalance between the phases must not exceed 3%). If these parameters are not respected, contact the electricity supply company.

For electrical connections, use double insulation cable in conformity with legislation in force in the country concerned..

⚠ A thermal overload switch and a lockable mains disconnect switch, in compliance with the CEI-EN standards (contact opening of at least 3mm), with adequate switching and residual current protection capacity based on the electrical data table shown below, must be installed as near as possible to the appliance.

⚠ An efficient earth connection is obligatory.
The manufacturer cannot be held liable for any damage caused by the failure to correctly earth the unit.

In the case of three phase units, ensure the phases are connected correctly.

⊖ Do not use water pipes to earth the unit.

Electrical data at maximum conditions allowed (full load)

Size	Power elettrica (V-Ph-Hz)	Maximum values									Fuses (5x20T 250V)		
		Compressor			Fan/Fans		Pump		Total		FU1	FU2	FU3
		F.L.I. (kW)	F.L.A. (A)	(1) (A)	F.L.I. (kW)	F.L.A. (A)	F.L.I. (kW)	F.L.A. (A)	F.L.I. (kW)	F.L.A. (A)			
BRAN 0011M H	230~50	3,3	16	25	0,15	0,6	0,21	1	3,7	17,6	1,25 A	8 A	2 A
BRAN 0025M H	230~50	4,1	19	37	0,15	0,6	0,21	1	4,4	20,6	1,25 A	8 A	2 A
BRAN 0041M H	230~50	5,0	27	59	0,3	1,2	0,42	2	5,7	30,3	4 A	8 A	2 A

F.L.I. Maximum power input

F.L.A. Maximum current input

(1) Start-up current

- Before connecting the unit to the power supply, make sure that switch QF1 is open, suitably padlocked and marked.
- Remove the inspection panel by unscrewing the screws.-

- Use cable gland **A** for the main electrical power cable and cable gland **B** for other external cables to be connected by the installer.

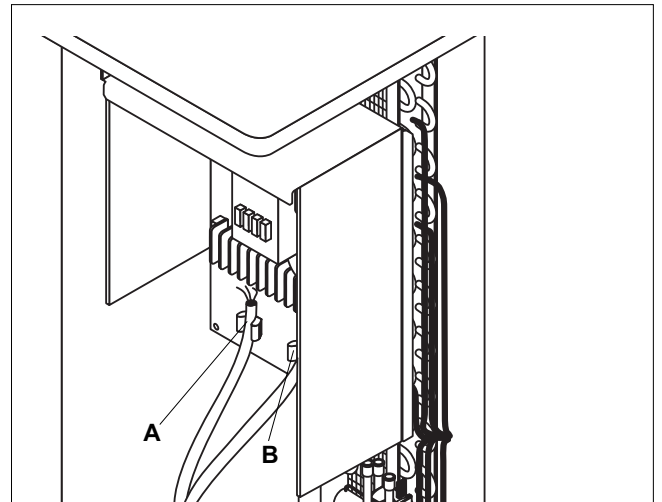
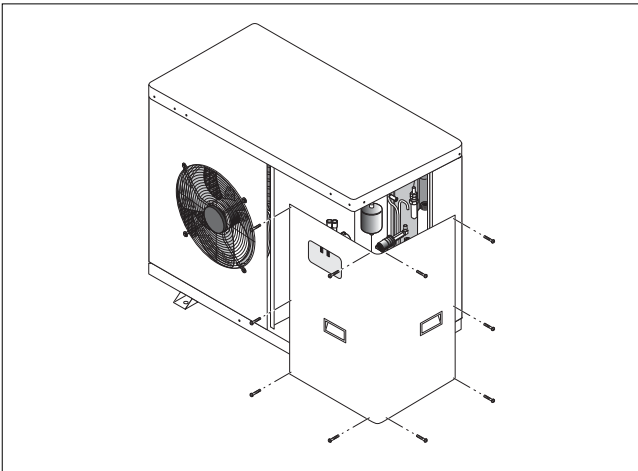

- Identify the terminals used for electrical connections on the layout drawing shown in this manual.
For the functional connection of the unit, bring the power supply cable to the electrical panel inside the unit and connect it to terminals U-N for units 0025-0041, to terminals T1 and T3 on the disconnect switch for units 0011, respecting the (U) phase, (N) neutral and (PE) earth in the case of single phase units (230V~50Hz), or U-V-W phases, N neutral and PE earth in three phase units (400V-3N~ 50 Hz).
- Reposition the inspection panel.
- Check that all the covers removed to make the electrical connections have been replaced before powering up the unit.
- Place the main switch QF1 (outside the unit) in the "ON" position.
- The "POWER" LED on the control panel comes on to signal that power is connected.
- The message ON is shown on the HSW11 control panel, signalling that power is connected.

ELECTRICAL PANEL LAYOUT

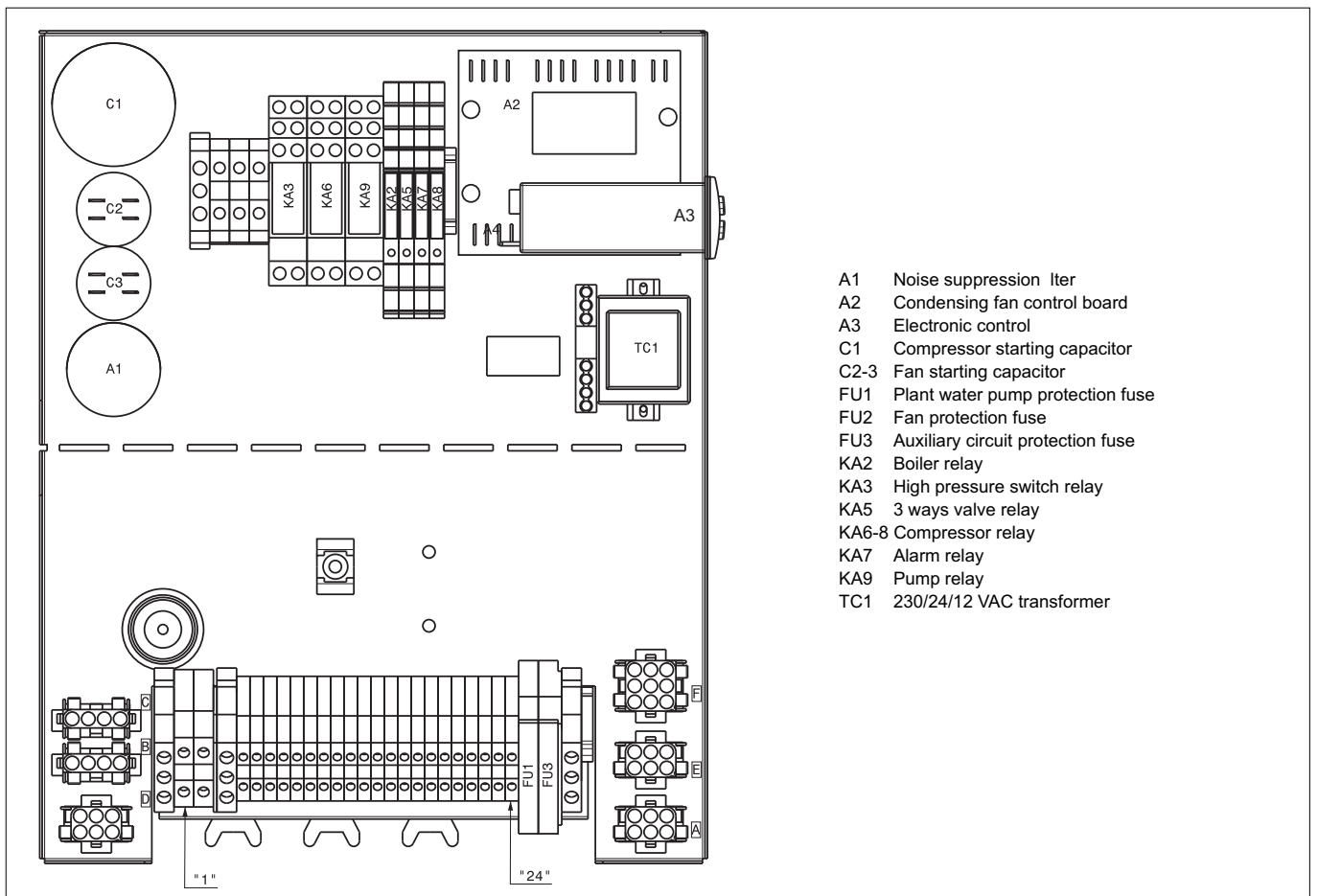

- A1 Noise suppression iter
- A2 Condensing fan control board
- A3 Electronic control
- C1 Compressor starting capacitor
- C2-3 Fan starting capacitor
- FU1 Plant water pump protection fuse
- FU2 Fan protection fuse
- FU3 Auxiliary circuit protection fuse
- KA2 Boiler relay
- KA3 High pressure switch relay
- KA5 3 ways valve relay
- KA6-8 Compressor relay
- KA7 Alarm relay
- KA9 Pump relay
- TC1 230/24/12 VAC transformer

All the terminals referred to in the following explanations are to be found on the terminal board located inside the electrical panel and called "installer terminals" (see wiring diagram).

REMOTE ON/OFF (SA1)

To use a remote on/off device, connect the contact of the device to terminals 14 and 15 on the installer terminal board. Set parameter CL42 = -1.

Remote off corresponds to standby status, with the compressor and pump off, yet all the safety features are active.

REMOTE ALARM (RD1)

For remote display of unit shut-down, an audible or visual alarm warning device can be connected between terminals 12 and 13.

Connect the phase to terminal 13 and the alarm signal device between terminal 12 and the neutral.

REMOTE KEYPAD KIT (A4)

The remote keypad kit can be used to display all unit functions and access the parameters of the electronic board from a point located at some distance from the unit itself. It consists of a remote control module.

To install the kit, proceed as follows:

- disconnect the power supply and then access the inside of the electrical panel;
- connect the remote control module with 3 wires to terminals 22, 23 and 24 on the installer terminal board:
 - terminal 22 connected to the GND/black terminal on the keypad;
 - terminal 23 connected to the signal/blue terminal on the keypad;
 - terminal 24 connected to the +12VDC/red terminal on the keypad;

⚠ To avoid interference due to magnetic fields, the use of shielded cable is recommended. The cable should not be more than 100 m long.

CONNECTING A FLOW SWITCH (F3)

If a flow switch is used, connect it to terminals 18 and 19 on the installer terminal board, after having removed the jumper.

COMPRESSOR ON SIGNAL (GN1)

TERMINAL BLOCK BRAN H SINGLE-PHASE

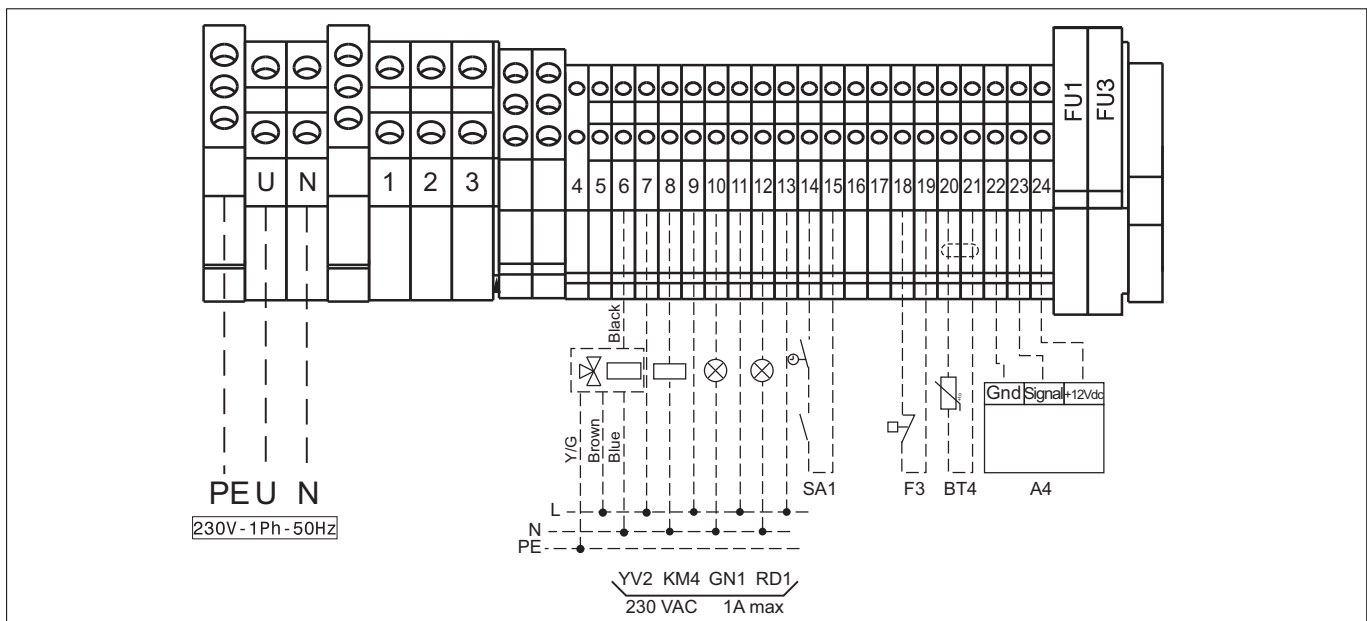

For remote display of the compressor operating status, an audible or visual alarm warning device can be connected between terminals 10 and 11.

Connect the phase to terminal 11 and the signal device between terminal 10 and the neutral.

DOMESTIC HOT WATER 3-WAY VALVE (YV2)

To configure a 3-way for the production of domestic hot water (supplied by manufacturer), make the following connections:

- terminal 7 on the heat pump connected to the phase L
- terminal 6 on the heat pump connected to the balck wire on the 3-way valve
- brown wire on the 3-way valve connected to Phase L
- blue wire on the 3-way valve connected to Neutral N
- yellow/green wire connected to earth

The valve is also fitted with a limit switch contact. The contact is either closed or open, depending on the position of the valve. Limit switch contact (red and green wire):

- Closed = Valve open
- Open = Valve closed

The 3-way valve for the production of domestic hot water, if not supplied by manufacturer, should have the following characteristics:

- Voltage 230V AC, 50/60 Hz
- Opening and closing time 10s.
- P delta 500 kPa
- Fluid temperature 0°C to 90°C

Use three-way valves with a pressure drop below 20 kPa.

DOMESTIC HOT WATER STORAGE TEMPERATURE SENSOR (BT4)

The domestic hot water temperature inside the storage cylinder is measured using sensor BT4, connected to terminals 20 and 21.

AUXILIARY HEATING ELEMENT (KM4)

If an auxiliary heating element is used, heater or boiler, connect the control device or contactor, as shown in the wiring diagram. For further details, see the chapter on "Operating characteristics".

SINGLE-PHASE WIRING DIAGRAM BRAN 0011-0025-0041 M H

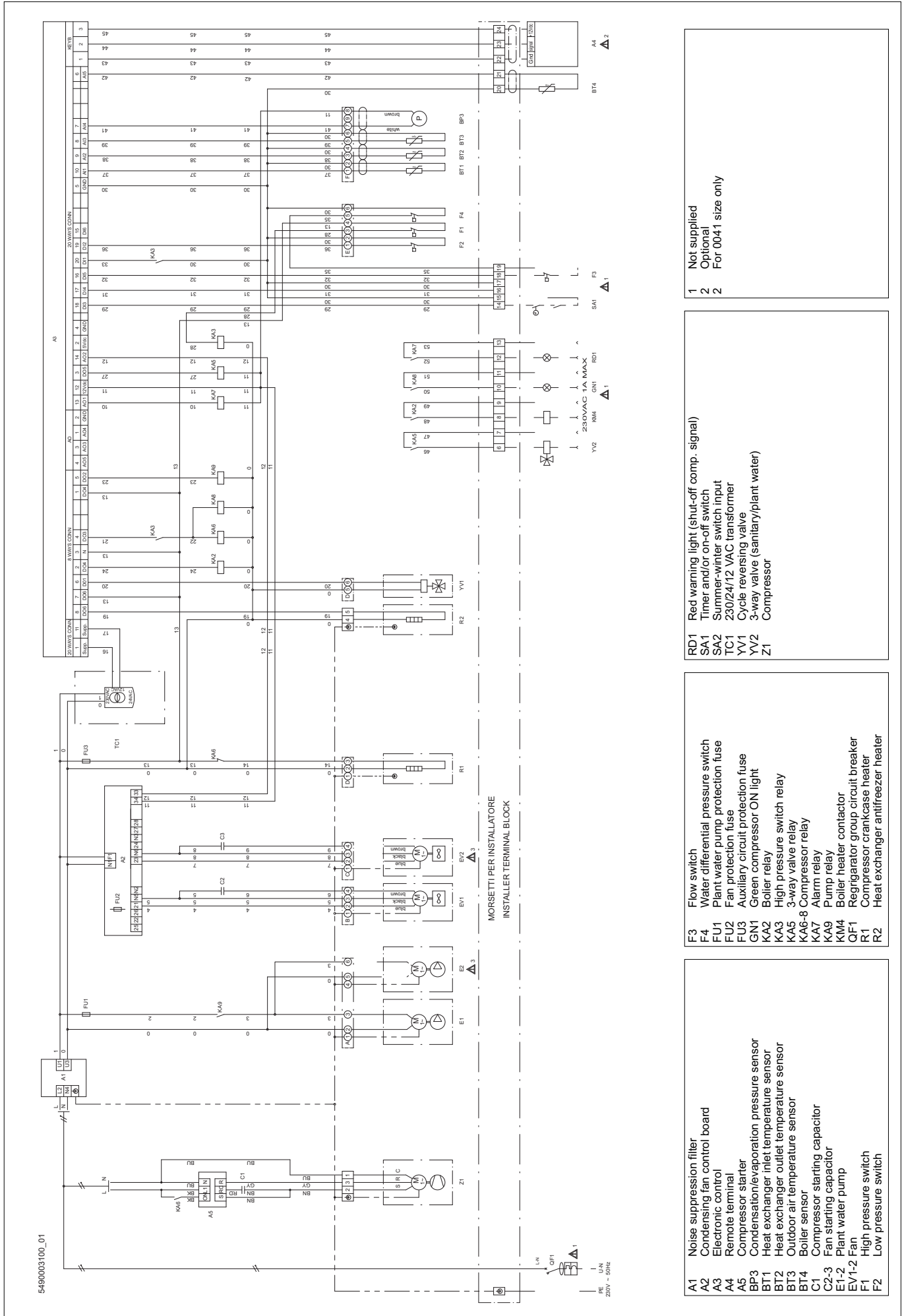

1 Not supplied
2 Optional
2 For 0041 size only

RD1 Red warning light (shut-off comp. signal)
SA1 Timer and/or on-off switch
SA2 Summer-winter switch input
TC1 230/24/12 VAC transformer
YV1 Cycle reversing valve
YV2 3-way valve (sanitary/plant water)
Z1 Compressor

F3 Flow switch
F4 Water differential pressure switch
FU1 Plant water pump protection fuse
FU2 Fan protection fuse
FU3 Auxiliary circuit protection fuse
GN1 Green compressor ON light
KA2 Boiler relay
KA3 High pressure switch relay
KA5 3-way valve relay
KA6-8 Compressor relay
KA7 Alarm relay
KA9 Pump relay
KM4 Boiler heater contactor
QF1 Refrigerator group circuit breaker
R1 Compressor crankcase heater
R2 Heat exchanger antifreezer heater

A1 Noise suppression filter
A2 Condensing fan control board
A3 Electronic control
A4 Remote terminal
A5 Compressor starter
BP3 Condensation/evaporation pressure sensor
BT1 Heat exchanger inlet temperature sensor
BT2 Heat exchanger outlet temperature sensor
BT3 Outdoor air temperature sensor
BT4 Boiler sensor
C1 Compressor starting capacitor
C2-3 Fan starting capacitor
E1-2 Plant water pump
F1 Fan
F2 Low pressure switch

Temperature control

Control is performed based on the system water return temperature.

The set points refer to the water return temperature.

The water outlet temperature depends on the difference between inlet and outlet, usually 5°C (rated).

This temperature difference may change depending on the type of water circuit.

For example, if the HEAT set point is set to +30°C, the outlet temperature will be +35°C.

The return temperature is also used to activate the resources inside or outside unit (e.g. electric heaters).

The controller features Full Floating technology that optimises, when the scan time elapses, the water temperature set points (HEAT/DHW) in relation to the compressor operating time and the water temperature.

To display the actual set point, select directory Sr and the active operating mode (Heat, DHW), as described in the paragraph "Displaying installer parameters".

Heating set point

(factory setting) = 40°C, Hysteresis = 3°C.

The compressor starts at outlet water temperatures below 37°C.

The compressor stops at water temperatures above 40°C.

In the event of temporary power failure, when power returns, the mode set previously will be retained in the memory.

COMPRESSOR START UP DELAY

Two functions prevent the compressor from starting up too frequently:

- Minimum time since last shut-down 3 minutes.
- Minimum time since last start-up 5 minutes.

CIRCULATING PUMP

The electronic board has an output for managing the circulating pump, always on in HEAT modes, and off with a 1 minute delay when unit shuts down (standby).

After the first minute of pump operation when the water flow is at full speed, the water flow alarm functions are activated (differential pressure switch and flow switch).

FAN SPEED CONTROL

To enable the unit to function correctly at different outside temperatures, a microprocessor with pressure reading via temperature sensor controls the fan rotation speed. This allows the exchange of heat to be increased and/or decreased, maintaining condensing or evaporation pressures essentially constant. The fan operates independently of the compressor.

FROST ALARM

The frost protection function is always active even if the controller is standby.

To prevent the water freezing and damaging the plate heat exchanger, the microprocessor shuts down the compressor if the temperature measured by the heat exchanger outlet temperature sensor is less than +4°C.

The frost prevention temperature set point can be modified by an authorised service centre only and only after verifying that the water circuit contains antifreeze.

Tripping of this alarm shuts down the compressor but not the pump, which remains active.

To reset normal functions, the water outlet temperature must rise to more than +7°C. Reset is automatic.

If the frost alarm is tripped more than 3 times in one hour, reset becomes manual.

DOMESTIC HOT WATER FROST PROTECTION

The domestic hot water frost protection function is only active if an auxiliary resource is installed for the domestic hot water storage (parameter CL61=28).

The auxiliary resource is activated if the water temperature, measured by sensor BT4, is less than +5°C, and is deactivated at +7°C.

WATER FLOW ALARM

The microprocessor manages a water flow alarm controlled by a differential pressure switch installed as standard on the unit, and a flow switch to be installed on the water outlet piping.

This safety device may trip after the first 60 seconds of pump operation, if the water flow-rate is not sufficient.

The alarm shuts down the compressor and not the pump, which remains active if the alarm lasts less than 20 seconds, otherwise the unit is shut down completely.

DYNAMIC DEFROST

The unit manages the defrosts by reversing the refrigerating cycle, switching the position of the reversing valve and operating the circuit in cooling mode for a few minutes with the fans off.

The defrost cycle removes the ice that forms on the surface of the outdoor heat exchanger external at low temperature and high humidity.

The unit controller features smart defrost management in relation to the temperature read by the outside air temperature sensor and the pressure in the refrigerant circuit.

The graph of the function is shown below.

The defrost cycle is started if the evaporation pressure falls below the effective start defrost set point, a value that may change, as represented in the graph, in relation to the outside air temperature.

A countdown starts, and only at the end is the cycle reversed to cooling mode, if the pressure remains below the effective start defrost set point

If it rises back above the effective start defrost set point, the defrost timer is set to zero.

The defrost ends when the set pressure value is reached or alternatively after a maximum time.

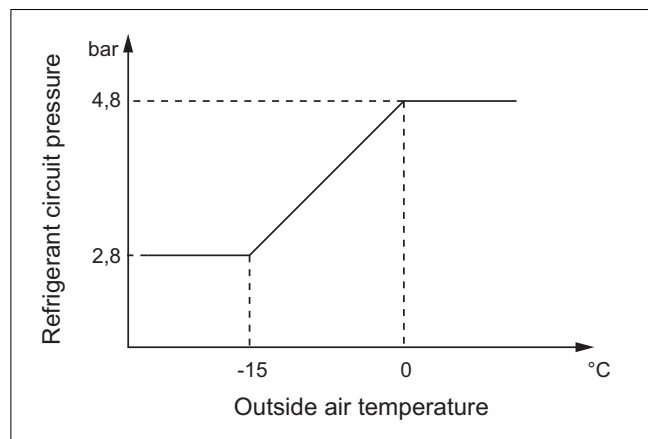

3-WAY VALVE MANAGEMENT FOR DOMESTIC HOT WATER (YV2)

The HSW11 controller manages domestic hot water production using a 3-way valve installed outside of the unit.

The production of domestic hot water is guaranteed in both summer and winter, according to the operating limits shown in this manual. An electric heater should be installed inside the DHW storage cylinder to ensure the temperature does not fall below 15/20°C in the event of extended periods of heat pump inactivity (standby).

Domestic hot water production is only enabled if the following conditions are satisfied:

- DHW storage temperature (sensor BT4) less than the DHW set point (AS01) minus the hysteresis (AS04); 3-way valve changeover to the domestic water storage;
- the time set for parameter AS10 has elapsed
- an Anti-Legionella cycle is not in progress (if activated by parameter)

Changeover from domestic hot water production to heating system hot water production:

- if the DHW storage temperature (sensor BT4) has reached the DHW set point (AS01); 3-way valve changeover to system;
- if the return water temperature (sensor BT1) has reached the DHW set point (AS01) plus a differential (AS05) that considers the possible temperature difference between the domestic water storage and the system return water temperature.
- if the maximum time (AS09) domestic hot water production time has elapsed.

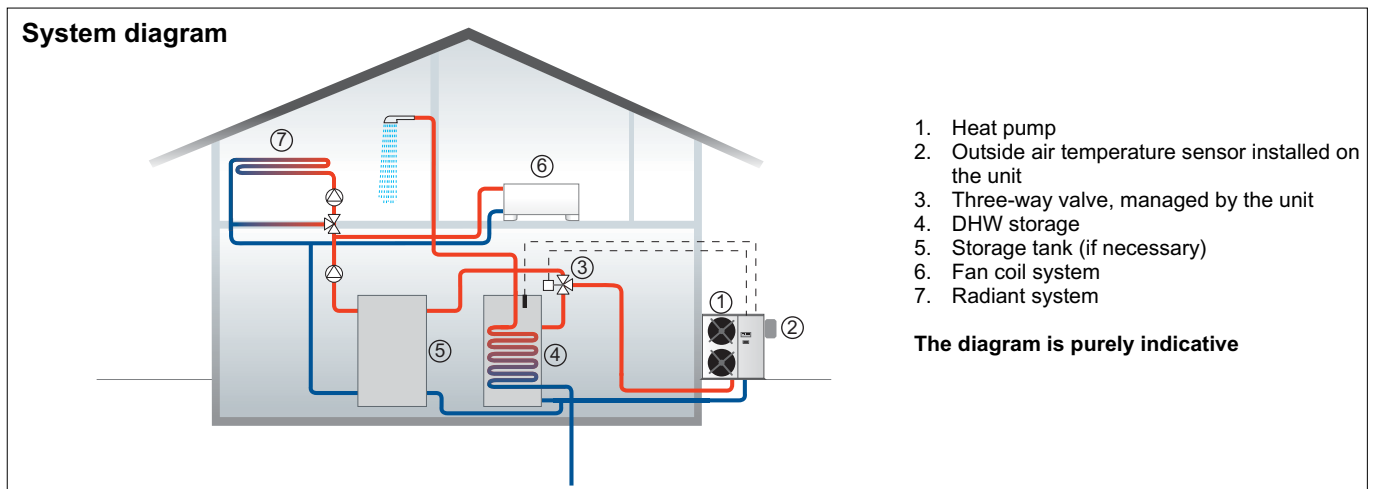

Parameter	Value	Description
AS00	0	Domestic hot water management disabled
	1	Domestic hot water production with heat pump only
	2	Domestic hot water production with DHW storage heater only
	3	Domestic hot water production with heat pump and DHW storage heater
AS01	50	Domestic hot water set point
AS04	3	Heat pump hysteresis for domestic hot water management
AS05	0	Heat pump operation differential on temperature control sensor (BT1)
AS09	60	Maximum domestic hot water production time with heat pump
AS10	15	Minimum interval between domestic hot water production requests with heat pump

For the electrical connections of the 3-way valve and the sensor BT4 in the DHW storage cylinder, see "Wiring diagram" and the chapter "Installer connections".

ADDITIONAL HEATER (OUTSIDE THE UNIT) (KM4)

The additional heater may be configured as:

- DHW storage heater.
- Boiler replacing the heat pump.

Additional DHW storage heater

The additional heater may be a electric heater or a boiler, to be connected as shown in the chapter on “installer connections”.

The device is activated if the storage temperature (sensor BT4) is less than the value calculated by:

$$\text{Water storage temperature (BT4)} < \text{AS01-AS07-AS06}$$

The device is deactivated if the storage temperature (sensor BT4) is above the value calculated by:

$$\text{Water storage temperature (BT4)} > \text{AS01-AS07}$$

Parameter	Value	Description
AS00	0	Domestic hot water management disabled
	1	Domestic hot water production with heat pump only
	2	Domestic hot water production with additional DHW storage heater only (e.g. electric heater)
	3	Domestic hot water production with heat pump and additional DHW storage heater (e.g. electric heater)
AS01	50	Domestic hot water set point
AS06	3	Additional heater domestic water hysteresis
AS07	0	Additional heater domestic water differential

Parameter AS00 defines the DHW storage heating mode (AS00=1 factory setting)

Boiler replacing the heat pump

This configuration manages a boiler rather than the heat pump, for water temperatures above the limits of the unit.

The boiler is enabled when the outside air temperature is less than the value of parameter HP05.

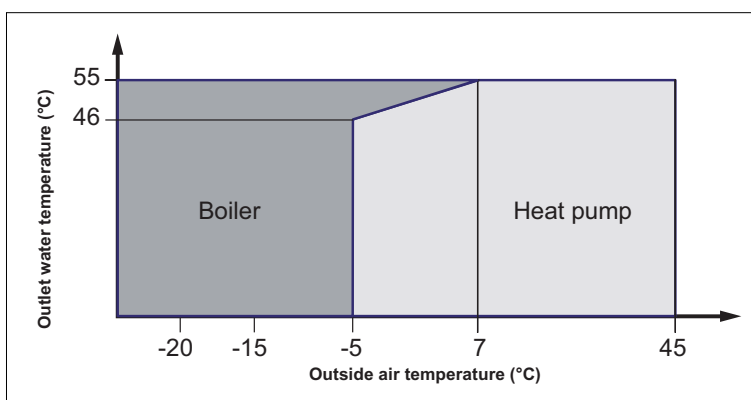

Parameter	Value	Description
CL61	30	Configuration of output KM4 as replacement boiler
HI20	0	Deactivation of heat pump heaters
HP03	-5	Differential from the maximum water temperature available with the heat pump
HP05	-12	Differential from rated outside air temperature (+7°C)
HP11	-5,1	Outside air temperature to shut down heat pump and activate the boiler
HP12	1	Outside air temperature hysteresis to enable the heat pump

ANTI-LEGIONELLA FUNCTION

The Anti-Legionella function ensures the elimination of the Legionella bacteria that reside in domestic water vessels; such bacteria typically die when the water temperature is above 70°C.

The Anti-Legionella function must be activated by an authorised technician.

This function is only available if an electric heater is fitted inside the DHW storage (see the function "DHW storage heater").

If the Anti-Legionella function is active, the domestic hot water is heated to 70°C for at least 60 minutes each Thursday of the week, starting at 2 am.

Deactivation of the Anti-Legionella cycle

The Anti-Legionella cycle ends if at least one of the following conditions is satisfied:

- the DHW storage temperature (sensor BT4) reaches the Anti-Legionella set point, parameter AS20
- the Anti-Legionella time has terminated, parameter AS34.

Parameter	Value	Description
AS06	3	Domestic hot water heater hysteresis for Anti-Legionella
AS20	70	Anti-Legionella set point
AS34	1h	Anti-Legionella cycle duration for Thursday
AS35	2	Anti-Legionella cycle start hours for Thursday
AS36	0	Anti-Legionella cycle start minutes for Thursday

If the Anti-Legionella cycle is not completed, the display shows a warning. Contact an authorised service centre.

SYSTEM WATER SET POINT COMPENSATION BASED ON THE OUTSIDE TEMPERATURE

The unit is fitted with an outside air temperature sensor that is used to optimise the energy efficiency of the unit based on the outside conditions.

Set point compensation based on the outside temperature must be enabled by setting a parameter, see the table.

System water set point compensation in HEATING mode based on the outside temperature

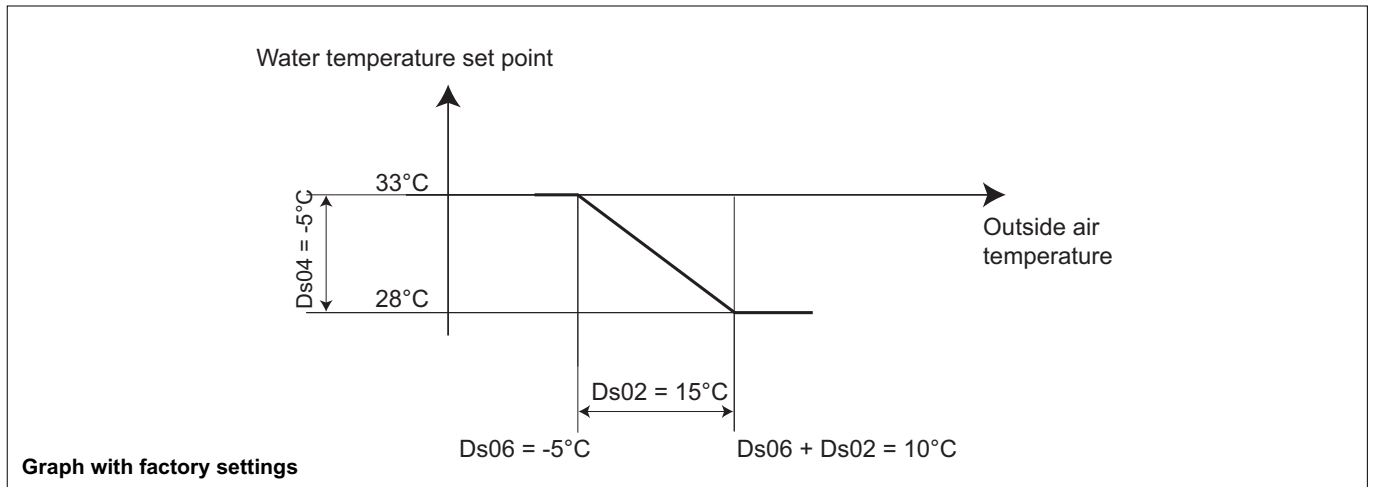

Parameter	Value	Unit of measure	Description
ds00	1		Enable system water set point compensation function
OPERATION IN HEATING MODE			
Ds02	15	°C	Differential applied to the value of ds06
DS04	-5	°C	Differential applied to the system water temperature set point in heating mode
Ds06	-5	°C	Outside air temperature activation/deactivation value for set point compensation function in HEATING

TIME BANDS

The HSW11 controller can manage the unit based on the time and the day of the week.

The controller features four time bands in three profiles that can be combined, when programming, with the days of the week.

The profile defines the behaviour of the unit over a 24 hour period.

Time band management must be enabled by parameter tE00 = 1 (tE00 = 0 standard setting).

Programming example

1) Define the profile for each time band, as shown in the following table.

Description	Description	Profile 1	Profile 2	Profile 3
TIME BAND 1	Hour / Minutes	hours 00 (tE10=0) / min.00 (tE11=0)	hours 00 (tE38=0) / min.00 (tE39=0)	tE66..tE67
	Operating mode ON/Standby	ON (tE12=0)	ON (tE40=0)	tE68
	Cool set point	tE13=15	tE42=15	tE69
	Heat set point	tE14=30	tE42=30	tE70
	DHW set point	tE15=50	tE43=50	tE71
TIME BAND 2	Hour / Minutes	hours 6 (tE17=6) / min.00 (tE18=0)	hours 7 (tE45=6) / min.00 (tE46=0)	tE73..tE74
	Operating mode ON/Standby	ON (tE19=0)	ON (tE47=0)	tE75
	Cool set point	tE20=12	tE48=12	tE76
	Heat set point	tE21=33	tE49=33	tE77
	DHW set point	tE22=45	tE50=45	tE78
TIME BAND 3	Hour / Minutes	hours 9 (tE24=9) / min.00 (tE25=0)	hours 7 (tE52=12) / min.00 (tE53=0)	tE80..tE81
	Operating mode ON/Standby	ON (tE26=0)	ON (tE54=0)	tE82
	Cool set point	tE27=15	tE55=12	tE83
	Heat set point	tE28=30	tE56=33	tE84
	DHW set point	tE29=50	tE57=45	tE85
TIME BAND 4	Hour / Minutes	hours 17 (tE31=17) / min.00 (tE32=0)	hours 17 (tE59=17) / min.00 (tE60=0)	tE87..tE88
	Operating mode ON/Standby	ON (tE33=0)	ON (tE61=0)	tE89
	Cool set point	tE34=12	tE62=12	tE90
	Heat set point	tE35=33	tE63=33	tE91
	DHW set point	tE36=45	tE64=45	tE92

↑
↑

Example of profile 1 to be used on opening days	Example of profile 2 to be used on closing days
--	--

2) Associate one of the three programmed profiles with each day of the week.

The days of the week are identified by the parameters tE01 to tE07; tE01 = Monday, tE02= Tuesday.....tE07=Sunday.

Once having displayed the day of the week, tE01 to tE07, select the value 1, 2 or 3 corresponding to Profile 1, Profile 2 and Profile 3 respectively.

Follow the operations shown below to program the profiles and combine them with the day of the week:



To access directory tE from the main display, press esc and set together. [esc+set].



Pressing these two buttons enters the menu with the list of directories.

Use the up and down buttons to scroll to the directory PAR. Press the set button and use the up and down buttons to scroll to the directory tE.



Press the set button to display the first parameter, tE00. Use the up and down buttons to scroll to the other parameters.

To set the selected parameter, press the set button and enter the value using the up and down buttons. Confirm the changes by pressing the set button or alternatively cancel by pressing esc.

BRAN H		0011M	0025M	0041M
Heating capacity (1)	kW	6,5	8,7	13,8
Effective input power according to EN 14511 (1)	kW	1,82	2,31	3,68
COP according to EN 14511 (1)		3,57	3,76	3,75
Heating capacity (1)	kW	6,5	8,7	13,8
Power absorbed (2)	kW	1,65	2,15	3,40
COP (2)		3,94	4,05	4,06
Rated water flow (1)	m ³ /h	1,12	1,50	2,37
Residual head (1)	kPa	41	48	89
Fans	n°	1	1	2
Air Flow	m ³ /s	0,9	1	1,9
Type of compressor		SCROLL		
No. of compressors	n°	1	1	1
No. of circuits	n°	1	1	1
Refrigerant R410A	Kg	1,75	3	3
Oil Mobil EAL ARTIC 22cc	Kg	1,1	1,24	1,95
Pump type		Circulator		
No. of pumps	n°	1	1	1
Functioning weight	kg	95	115	140
Hydraulic connections	inches	3/4	3/4	1 1/4
Sound power level according to EN ISO 3744	dB(A)	72	73	73
Sound pressure (3)	dB(A)	61	62	62
Electric power supply	V/ph/Hz	230~50		

(1) Heat pump mode: External air temperature 7°C DB- 6°C WB, water in flow at 30°C and out flow at 35°C

(2) The total input is given by the compressor input + fans power input

(3) Noise level measured in free field at a distance of 1 metre

OPERATING LIMITS

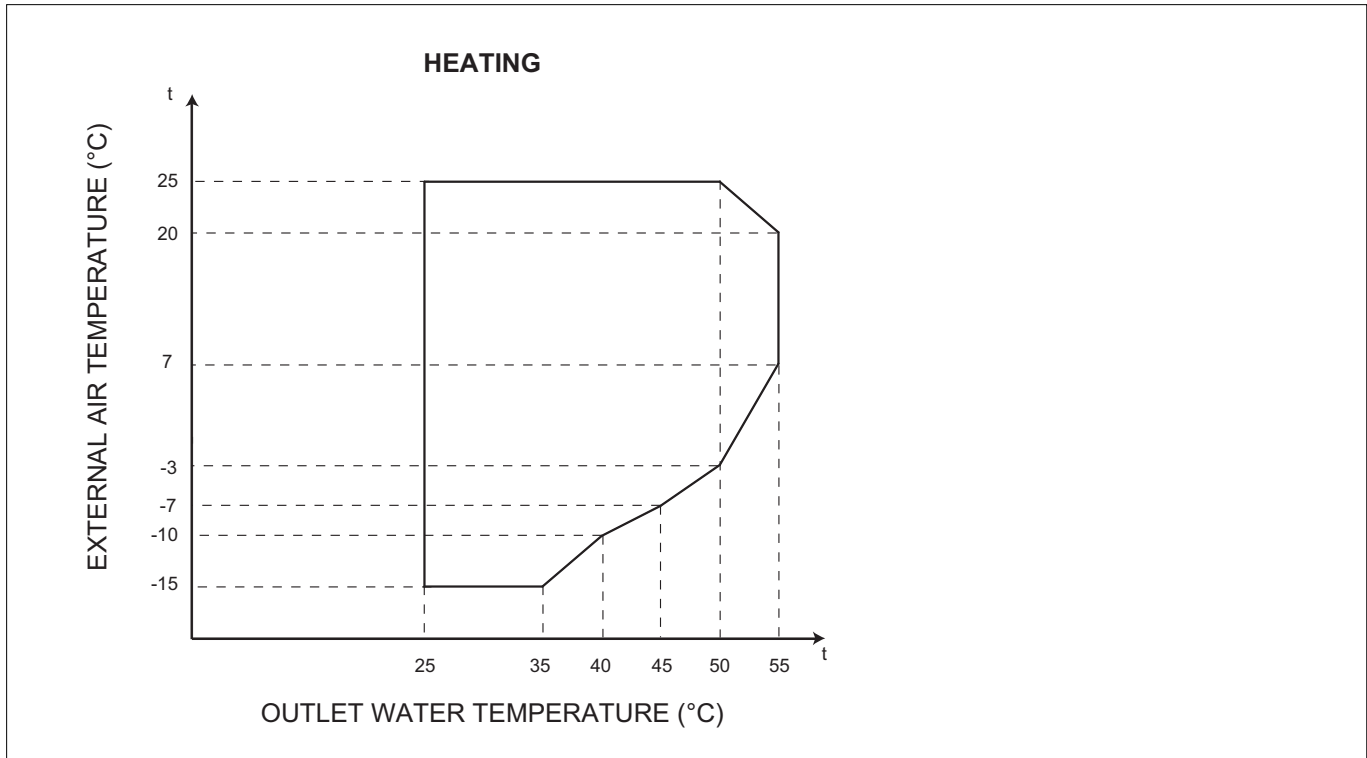

Min-max water thermal gradient	4÷6
Min-max water circuit pressure (bar)	1÷3
Max. storage temperature (°C)	63

PREPARING FOR FIRST START UP

The unit must be started up for the first time by the **Technical Service**: Before starting up the units, make sure that:

- All safety conditions have been respected;
- The unit is adequately fixed to the surface it rests on
- Functional distances have been respected;
- Water connections have been carried out as indicated in the instruction manual;
- The water circuit is filled and vented. When draining after heat pump operation, take care as the water may be hot;
- The water valves are open;
- Electrical connections have been carried out correctly
- Voltage is within a tolerance of 10% of the rated voltage for the unit;
- The unit is correctly earthed;
- All electrical connections are tight and all water connections have been carried out correctly.

⚠ The unit must be started up for the first time with standard settings. Set Point values may be modified only after testing has been completed.

Before starting up, power up the unit for at least two hours by switching QF1 and QS1 to ON (see wiring diagram) and the control panel "HSW11" to OFF (message "off") to allow the oil in the compressor sump to heat up.

STARTING UP FOR THE FIRST TIME (after two hours)

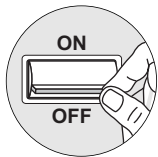

Before starting the unit:

- Make sure the switch QF1 is in the OFF position.
- Make sure the contact of the on/off device SA1 (see the wiring diagram) is open (if featured).
- Make sure the remote keypad "A4" (see wiring diagram) shows OFF (if featured).

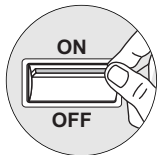

- Close the door of the electrical panel.
- Move the main unit switch QS1 to the ON position;
- Move the switch QF1 (outside the unit) to "ON".

- The message ON is shown on the control panel HSW11, indicating power is connected.

⚠ For the position of internal components, see the diagrams.

ACTIVATING AND DEACTIVATING THE UNIT

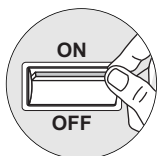

- Move the contact on the on/off device SA1 (if featured) to ON.
- Switch the remote keypad "A4" (if featured) ON.
- The COOLING and HEATING are ACTIVATED and DEACTIVATED on the control panel "HSW11" or the remote keypad "A4" if featured.

⚠ During this phase, if the following indications appear on the display, follow the instructions:

- ER20 check the water flow-rate and the connection (16 and 17) of the flow switch or differential pressure switch.
- ER01 (three-phase heat pumps only): check the power supply connection and if necessary reverse two phases.

To access the control panel, open the door:

- remove the screw 1;
- press the points 2 simultaneously and lift the door 3.

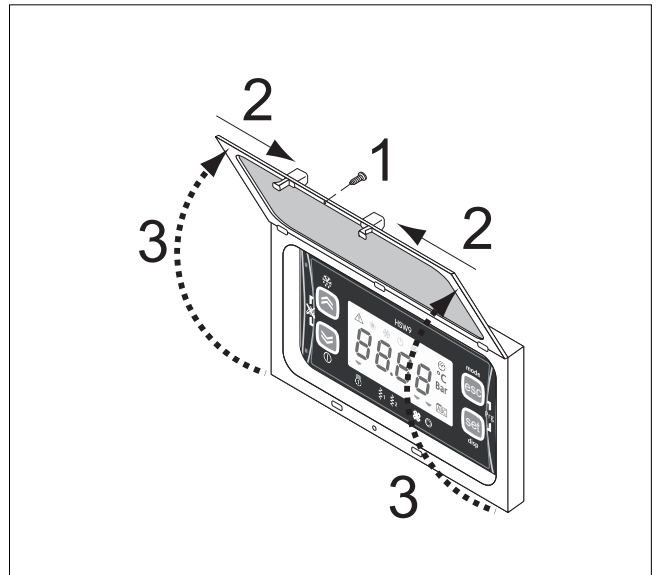

⚠ At every change of season, make sure the operating conditions fall within the limits specified.

Make sure the current input of the compressor is less than the maximum shown in the table of technical specifications.

In three-phase models, **check** that the noise levels of the compressor are not abnormal. If this is the case, reverse one phase.

Make sure the voltage is within the established limits and that, for three phase units, the unbalance between the phases is less than 3%.

Check that the cover is closed again following the setting procedure.

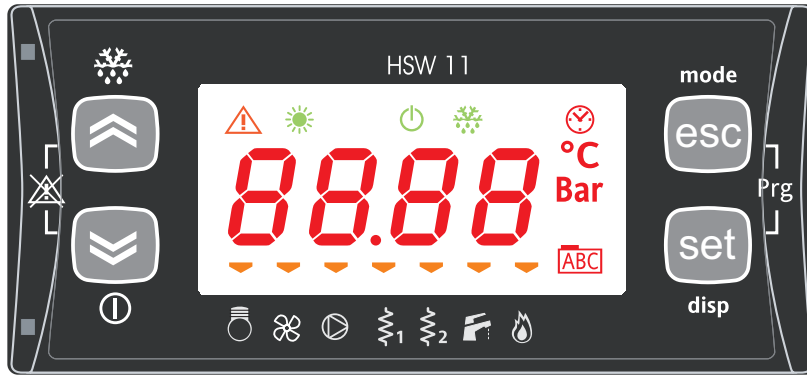

DESCRIPTION OF THE BUTTONS AND ASSOCIATED FUNCTIONS

Button	Description	Press once [press and release]	Associated function	Press and hold [press for about 3 seconds]	Menu / Notes
	UP	- Increases a value - Goes to the next label		[Manual defrost activation]	Functions menu see Functions chapter (folder FnC)
	DOWN	- Decreases a value - Goes to the previous label		[Local ON/OFF]	See Local On/OFF section See also Functions menu Functions chapter (folder FnC)
	Esc(ape) Output (Without saving new settings)	- Exit without saving new settings - Go back to previous level	mode	[Change mode] See section on Changing operating mode	Operating mode menu
	Set Confirm (save new settings)	- Confirms value / exit and save new settings - Move to next level (open folder, subfolder, parameter, value) - Accede al Menu Stati	disp	[Main display] See Main Display section	[Main Display Menu]
	ALL	- Alarm acknowledgment			See Manual alarm acknowledgment and reset section

DESCRIPTION OF THE BUTTONS – COMBINED ACTION

Symbol [function associated with the combined action of the buttons]	Combination of buttons	Combined action of the buttons Pressed once (press and release)	[associated function]	[Menu] / Notes
		[UP + DOWN]	[Manual reset]	
Prg		[Esc + Set]	[Open programming menu]	[Programming menu]

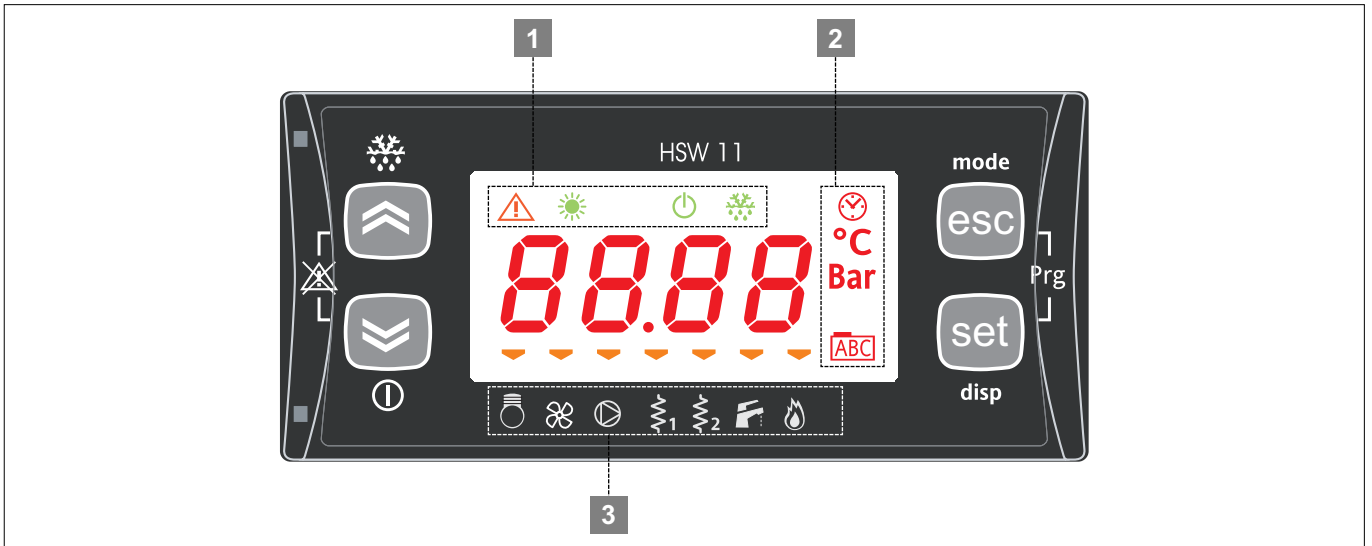

1 STATUS AND OPERATING MODE LEDS

	Alarm
	Heating
	Standby
	Defrost

2 VALUE AND UNIT OF MEASURE LEDS

	Clock (RTC)
	Degrees centigrade
	Pressure (Bar)
	Menu (ABC)

3 UTILITY LEDS

	Compressor
	Not used
	Not used
	Fan
	System pump
	Domestic hot water function activation
	External auxiliary heating element activation

SETTING THE CLOCK

The HSW11 controller is fitted with a clock for managing time bands to control specific events. Follow the procedure shown below to set the hours, minutes and date.



To set the clock of the unit, starting from the main display, press the set button.

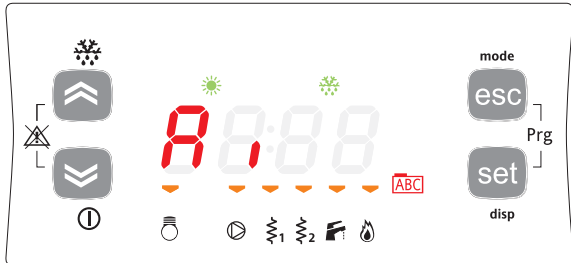

Pressing the set button once displays the various directories. Scroll the menu using the UP and DOWN buttons until reaching the directory CL.

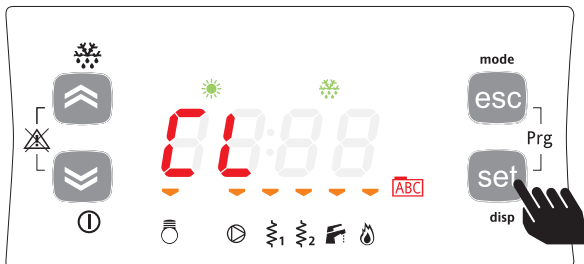

To enter menu CL press the set button.

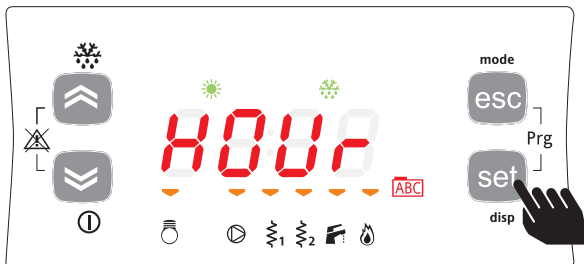

Once having entered this menu, HOUr will be shown. Select whether to set the time, date or year using the UP and DOWN buttons.

Once having decided which value to set, press the [set]** button to enter the corresponding menu.

**pressed and held for 3 around seconds.

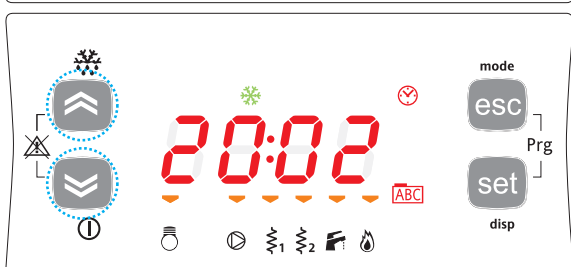
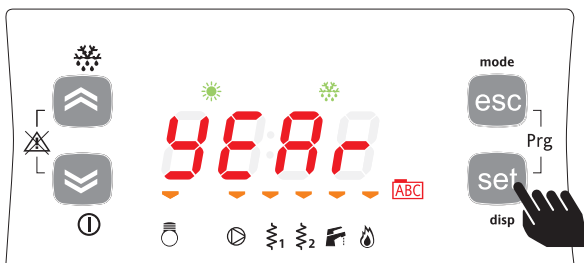
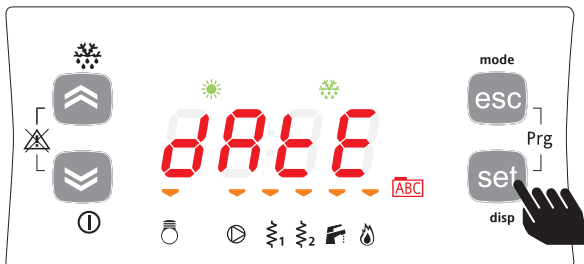

To set the time, date and year simply scroll with the UP and DOWN buttons until the desired value and



... press the set button.

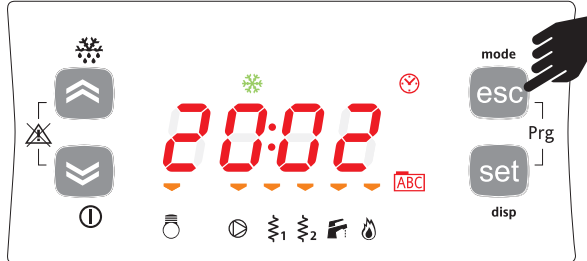

To exit the clock setting menu press the esc button until returning to the main display.

SELECTING THE OPERATING MODE

There are three different modes:

- Standby mode (StbY); in standby the compressor and pump are off but all the safety features are active
- Heating mode (HEAT)

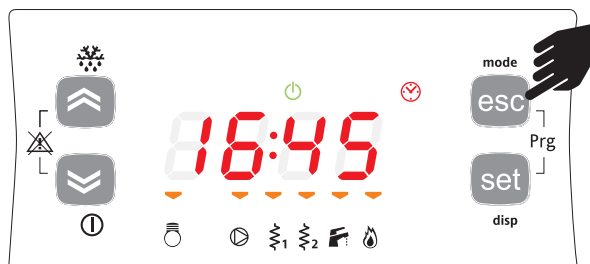

For example, to switch operation from StbY to HEAT.

To change the operating mode, press and hold the mode button for at least 2 seconds.

PS: The main display is set as RTC (current time).

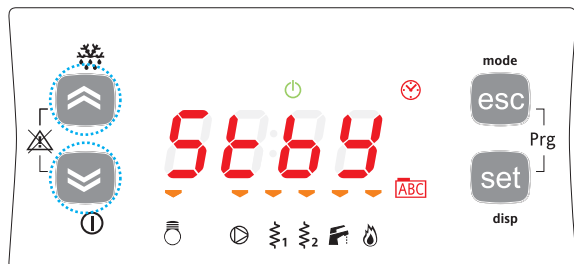

A scroll menu will start flashing with the values StbY (standby), HEAT (heat).

Use the up and down buttons to select the desired operating mode.

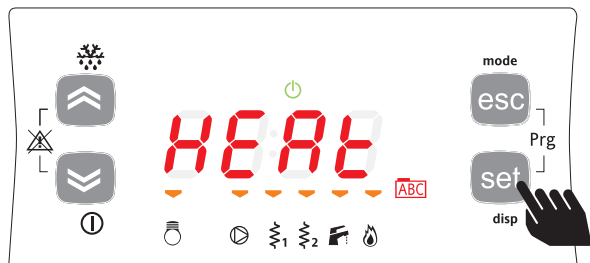

Once having selected the operating mode, press the set button.

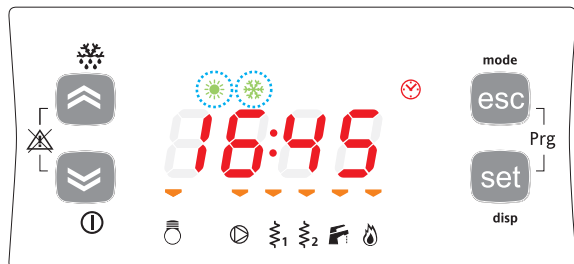

The unit will automatically return to the main display and the Stby LED, previously on, will now be off and the HEAT LED will be on.

SETTING THE SET POINTS

As an example, the Set Point in HEAT mode will be changed from 45 degrees centigrade to 48 degrees centigrade.

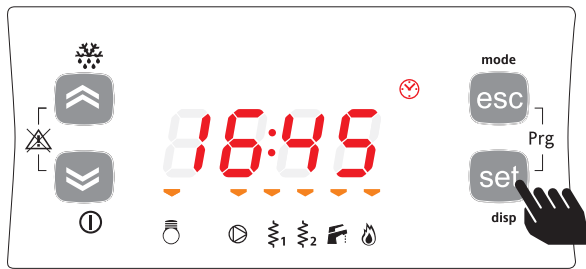

To change the set point, starting from the main display, press the set button.

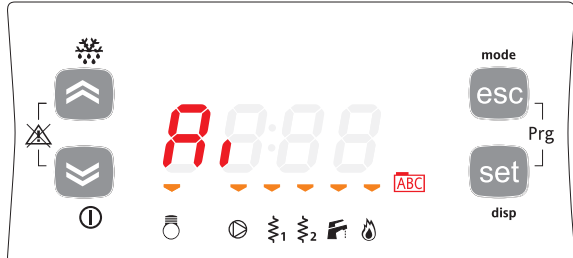

Pressing the set button once displays the various directories. Scroll the menu using the up and down buttons until reaching the SP directory.

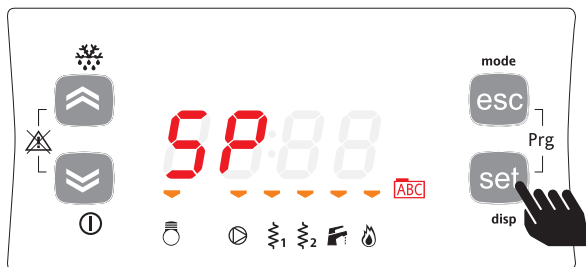

To enter the SP directory press the set button.

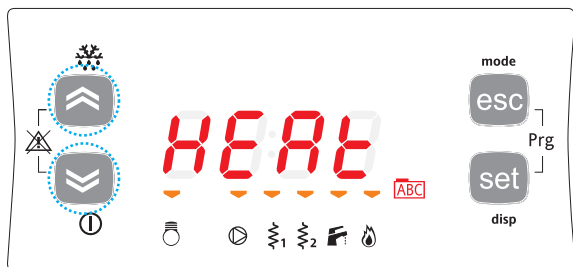

The first mode displayed will be HEAT, then scrolling with up and down to HEAT and DHW modes (as shown on the side).

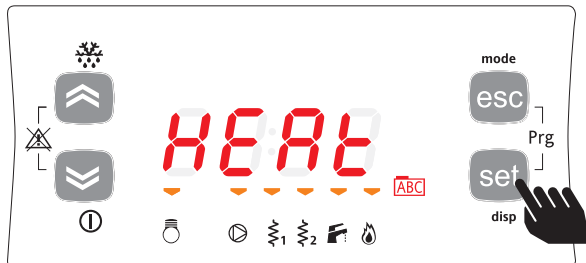
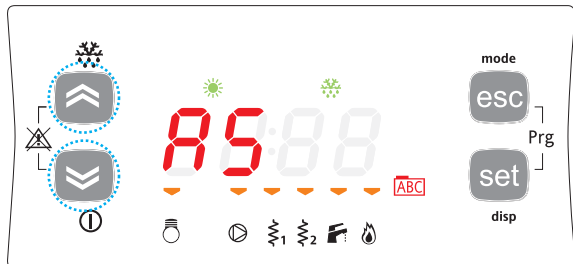

Taking the example of changing the set point for HEAT mode. Select HEAT from the menu and press the set button.

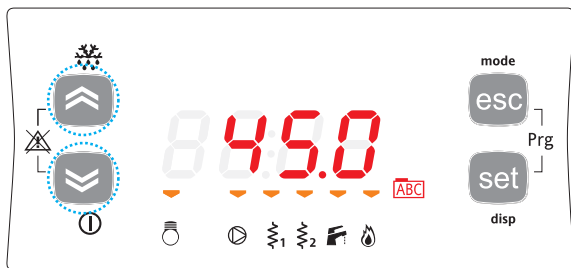

The instrument will display the current set point (in this case 45 degrees centigrade).

To increase or decrease the value, use the up and down buttons.

For example, to change the set point to 48 degrees, press the up button until the desired value is displayed.



Once having reached the desired set point, press the set button.

In this way, the instrument will save the value 48.



To return to the main display, press esc or wait for the menu timeout to expire (15 seconds).

SUMMER MODE

Change the set point for heating HEAT at the minimum (10°C), follow the operations shown above. The heat pump work only to produce domestic hot water.

DISPLAYING INSTALLER PARAMETERS



From the main display, press the set button.

Example of displaying the analogue inputs.

For the other I/Os the procedure is essentially the same***.

The display will show label Ai.

(Scroll the other labels using the UP and DOWN buttons until reaching the desired label).

Press the set button to display the label for the first analogue input (in this case AiL1).

Press the set button again to display the value of AiL1. Note that the °C icon comes on to indicate that the value displayed is in degrees centigrade.

***In the case of the digital inputs / analogue inputs configured as digital inputs, the value will be:

- 0 = input inactive (for digital inputs this corresponds to the input being open, for analogue inputs configured as digital inputs it corresponds to the input being shorted to earth).
- 1 = input active (for digital inputs this corresponds to the input being shorted to earth, for analogue inputs configured as digital inputs it corresponds to the input being open)..

To change the value of the parameter press the up and down buttons.

When having selected the value, press the set button. **

To exit the display and return to the previous level, press esc.

**NOTE: pressing the set button confirms the new value; pressing the esc button returns to the previous level without changing the existing value.

To exit the menu, press esc until returning to the main display.

DISPLAYING AUTHORISED TECHNICIAN PARAMETERS

Accessing the PASS directory (from the main display, pressing the esc and set buttons together [esc+set] and scrolling to the directory with up / down) and setting the PASS accesses the parameters visible for the password entered.

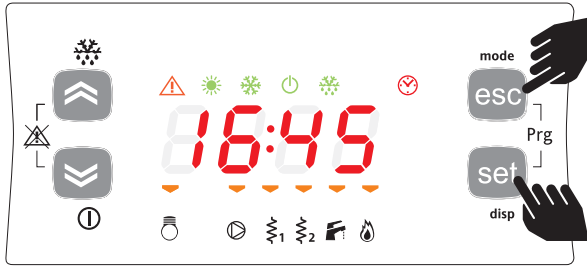

To access the PASS directory from the main display, press esc and set together [esc+set].



Pressing the two buttons accesses the menu listing the directories.
Scroll using the up and down buttons to the PASS directory.



To enter the PASS directory press the set button.
Then enter the password (installer or manufacturer), press set and exit.
Access the parameters to display or change the values.

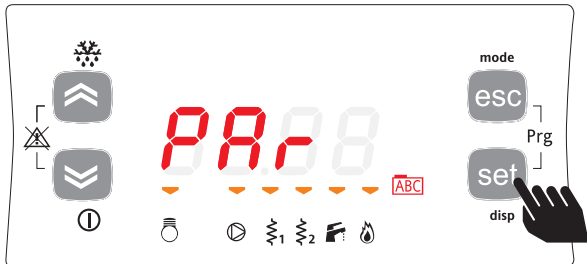

Press the up and down buttons to select the Par submenu.
Press the set button to display the desired directory.



The first directory displayed by the instrument will be the CF directory (configuration).
To set the individual CF parameters, simply press set again.

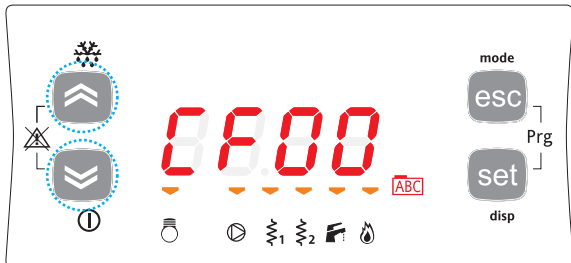

The instrument will display parameter CF00 (default factory settings).

To scroll the various parameters, simply press the up button to go to the next parameter (in this case CF01) or the down button to go to the previous parameter (in this case CF47).

CF00->CF01->CF02->...->CF47->CF00

CF47<-CF00<-CF01->...<-CF46<-CF47

NOTE: -> UP, <-DOWN



To display the value of the parameter (in this case CF00), press the set button.



For parameter CF00, the value displayed will be 2.
To change the value of the parameter, press the up or down button.

When having selected the value, press the set button. **
To exit the display and return to the previous level, press esc.

**NOTE: pressing the set button confirms the new value; pressing the esc button returns to the previous level without changing the existing value.

DISPLAYING AND RESETTING COMPRESSOR/PUMP HOURS



Example of displaying and resetting (tens) the operating hours for Pump 2.

From the main display, press the set button.

The display will show label Ai. Scroll the labels using the up and down buttons until reaching label Hr.

Press the set button to display the first label, in this case the operating hours for compressor 1 (CP01).

Scroll using the UP and DOWN buttons until displaying (if featured among the resources) the operating hours for compressor 2 (CP02) and the operating hours for the pumps (PU01, PU02).

Press the set button to display the operating hours for pump PU02.

The tens of operating hours are 2.
(The hours are expressed in tens: 2 indicates 20 operating hours).

To reset the operating hours for pump PU02, press and hold [set].

Note: to reset the operating hours for the other resources, repeat the procedure described.

To exit the menu, press esc until returning to the main display.

DISPLAYING ALARMS

The alarm signals are displayed flashing. The following procedure describes how to mute an alarm.
The various errors will be displayed in directory AL (see Status menu)



From the main display, press the set button

The display will show label Ai. Scroll the other labels using the UP and DOWN buttons until reaching label AL.

Press the set button to display the label for the first active alarm (if this exists).

In this case, the first alarm is Er01. Scroll any other active alarms using the UP and DOWN buttons.

NOTE: the menu is not cyclical.

For example, if alarms Er01 Er02 and Er03 are active, the display will be:

Er01 ->Er02->Er03 <-Er02<-Er01

NOTE: -> UP, <-DOWN

To exit the menu, press esc until returning to the main display.

RESET ALARM LOG

Below are the instructions on how to reset the alarm log if the alarm signal Er90 is shown.

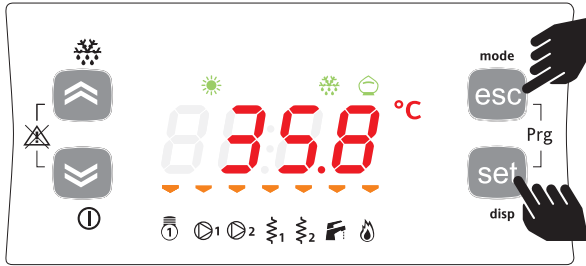

To access directory FnC from the main display, press esc and set together. [esc+set].



the first directory displayed is PAR.



Use the UP and DOWN buttons to scroll to the directory FnC.

Press the set button to access the Functions menu.



The first label displayed is dEF.

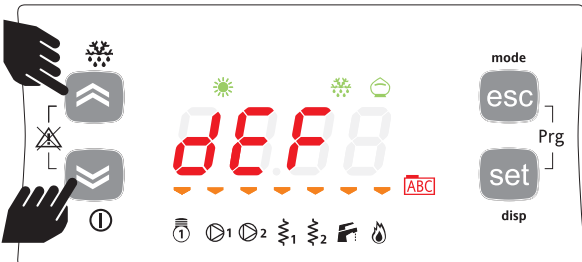

Use the UP and DOWN buttons to select directory EUr.



Press the set button for 3 seconds.



The display shows YES, to confirm that the alarm log has been reset.
Press Esc to exit.

LIST OF ACCESSIBLE PARAMETERS				
	Directory label	Meaning of the code (label)	Parameters	Parameters for:
	CL	ConFiguRation	CL00... CL97	Analogue input/output configuration
	Cr	ConFiguRation	Cr00... Cr50	Analogue input configuration
	CF	ConFiguRation	CF01... CF61	Serial configuration
	Ui	User interface	UI00... UI36	User interface
	tr	thermoregulation	tr00... Tr44	Temperature control
	St	Stati (Modi di funzionamento)	St00... St05	Operating status
	CP	ComPressori	CP00... CP27	Compressor
Pump	PI	Pump (Internal)	PI00... PI52	Primary water circuit pump
Fan	FI	Fan (Internal)	FI00... FI03	Circulation fans (inside)
	FE	Fan (External)	FE00... FE59	Fans (outside) once-through heat exchanger
Pump	PE	Pump (External)	PE00	Pump once-through heat exchanger
Electric heaters	HI	Electric Heaters (Internal)	HI00... HI26	Electric heaters, primary heat exchanger
	HE	Electric Heaters (External)	HE00... HE15	Electric heaters, once-through heat exchanger
	HA	Electric Heaters (Auxiliary)	HA00... HA02	Auxiliary electric heaters
	br	boiler	br00... Br05	Boiler
	dF	deFrost	dF00... dF32	Defrost
	dS	dynamic Setpoint	dS00... dS06	Dynamic set point
	Ad	Adaptive	Ad00... Ad06	Adaptive
	AF	AntiFreeze	AF00... AF03	Frost protection
	AS	PAR/AS	AS00... AS45	Domestic hot water
	HP	PAR/HP	HP00... HP12	Table of heat pump shut-down function parameters
	PL	Power Limitation	PL00... PL22	Forced capacity control
	tE	PAR/tE	tE00... AL92	Time bands
	AL	ALarm	AL00... AL82	Alarms

Note: when setting the parameters the COMPRESSOR and HEATER LEDs will flash alternating with the DEFROST LED.

DISPLAYING ALARMS



FAULT	CAUSE	SOLUTION
Values display indication Er01	High pressure switch tripped, manual reset after 3 activations in one hour, incorrect connection of power supply phases (three-phase models only)	Check fault (see high discharge pressure) Reset manually Change the position of two phases.
Values display indication Er03	High pressure switch from transducer tripped	Check the fault Check high discharge pressure Check the operation of the high pressure switch Check the wiring diagram Replace the component
Values display indication Er05	Low pressure switch tripped, manual reset after 4 activations in one hour	Check the fault
Values display indication Er07	Low pressure switch from transducer tripped	Check the fault Check low discharge pressure Check the operation of the low pressure switch Check the wiring diagram Replace the component
Values display indication Er20	Differential pressure switch or flow switch tripped Manual reset if active for more than 30 seconds	Check inadequate water flow Check for air in water circuit Check electrical connection (see unit wiring diagram)
Values display indication Er30	Frost prevention alarm (manual reset)	Check water outlet temperature Check water flow Check temperature Set Point Check correct positioning of sensor BT2

FAULT	CAUSE	SOLUTION
Values display indication Er35	High water outlet temperature	Alarm with automatic reset Check water outlet temperature Check water flow Check water temperature Set Point Check correct positioning of sensor BT2
Values display indication Er47	HSW11 communication error with remote keypad (only if remote keypad featured)	Check electrical connection
Values display indication Er 48	Anti-Legionella cycle not completed	Contact the authorised service centre
Values display indication Er60	Faulty BT1 water return sensor (automatic reset)	Check electrical connections Replace component
Values display indication Er61	Faulty BT2 water outlet sensor (automatic reset)	Check electrical connections Replace component
Values display indication Er66	Faulty domestic hot water sensor BT4	Check electrical connections Replace component
Values display indication Er68	Outside air sensor BT3 malfunction (automatic reset)	Check electrical connections Replace component
Values display indication Er75	Pressure transducer malfunction	Check electrical connection (see unit wiring diagrams) Replace the component
Values display indication Er81	Compressor maintenance interval	Check operating pressure Check condition of the compressor Reset the clock
Values display indication Er85	Water pump maintenance interval	Check condition of the water pumps Reset the clock
Values display indication Er90	Maximum alarm log size exceeded	Reset alarm log

SHUTTING DOWN FOR LONG PERIODS

A

After deactivating the heat pump:

- Make sure the remote switch SA1 is open, or alternatively disconnect the unit from the power supply.
- Make sure the remote keyboard (if present) is set to "OFF".
- Place QF1 in the OFF position (see wiring diagram).
- Deactivate the indoor terminal units by placing the switch of each unit in the "OFF" position.
- Close the water valves.

⚠ **If the outside temperature** may fall below zero; there is the risk of freezing.
The water circuit **MUST BE EMPTIED AND CLOSED** (if

draining after operation in heat pump mode, beware that the water may be hot), or antifreeze must be added in the proportion recommended by the manufacturer.

It is recommended to use non-toxic food grade antifreeze, compliant with the standards in force in the countries where the unit is used, if domestic hot water production is also featured.

If the mains switch is turned to "OFF" for more than four hours, after turning it on and before reactivating the unit, leave the power on but the unit deactivated for at least two hours to preheat the oil in the compressor sump.

Never perform any cleaning operations before having disconnected the unit from the mains power supply.

Terminals 6, 7, 8 and 9 may be live even when the unit has been disconnected.

Check for voltage before proceeding.

Regular maintenance is fundamental to maintain the efficiency of the unit both in terms of operation and energy consumption.

The Technical Service maintenance plan must be observed, with an annual service which includes the following operations and checks:

- Filling of the water circuit;
- Presence of air bubbles in the water circuit;
- Efficiency of safety devices;
- Power supply voltage;

- Power input;
 - Tightness of electrical and water connections;
 - Condition of the compressor contactor;
 - Efficiency of the plate heat exchanger heater;
 - Verification of operating pressure, superheat and subcooling
 - Efficiency of the compressor heater
 - Cleaning of the finned coil every three months
 - Cleaning of the fan grills
 - Cleaning of condensate drain pan (if installed);
- For units installed near the sea, the intervals between maintenance should be halved.

SPECIAL MAINTENANCE

Never perform any cleaning operations before having disconnected the unit from the mains power supply.

Terminals 6, 7, 8 and 9 may be live even when the unit has been disconnected..

Check for voltage before proceeding.

CHEMICAL WASHING

It is recommended to chemically flush the plate heat exchanger after every 3 years of operation.

For instructions on how to carry out this operation, call the toll free number.

REFRIGERANT GAS CONTENT

The chillers are charged with R410A refrigerant gas and tested in the factory.

In normal conditions, there should be no need for the Technical Service to intervene to check the refrigerant gas.

However, over time, small leaks may develop at the joints leading to loss of refrigerant and draining of the circuit, causing the unit to function poorly.

In this case, the leaks of refrigerant must be identified and repaired and the refrigerant circuit recharged.

Proceed as follows:

- Empty and dry the entire refrigerant circuit using a vacuum pump connected to the low and high pressure tap until the vacuum reads about 10 Pa.
Wait a couple of minutes and check that this value does not rise to more than 50 Pa.
- Connect the refrigerant gas cylinder or a filling cylinder to the low pressure line pressure gauge connection
- Charge the quantity of refrigerant indicated on the unit's rating plate.

- Always check the superheat and subcooling values, which should be between 5 and 10 °C and 4 and 8 °C.
- After a couple of hours operation, check that the liquid indicator indicates a dry circuit (dry-green).

⚠ In the event of partial leaks, the circuit must be completely emptied before being recharged.

The R410A refrigerant must only be charged in the liquid state.

Operating conditions other than rated conditions may produce considerably different values.

Tightness testing or identification of leaks must only be carried out using R410A refrigerant gas, checking with a suitable leak detector.

The refrigerant circuit **must not be charged** with a refrigerant other than that indicated on page 16.

The use of a different refrigerant may cause serious damage to the compressor.

⊘ Oxygen, acetylene or other flammable or poisonous gases must never be used in the refrigerant circuit as they may cause explosion or poisoning.

Oils other than those indicated on page 16 **must not be used**.

The use of a different oil may cause serious damage to the compressor.

DISPOSAL

The unit must be disposed of according to the legislation in force in the country concerned

FAULT	CAUSE	SOLUTION
The heat pump doesn't start	No voltage	Check presence of voltage Check safety systems upstream of the appliance
	Switch QF1 in OFF position Remote switch (if featured) in OFF position Control panel set to OFF Main switch QS1 in OFF Compressor thermal overload switch OFF	Switch ON
	Supply voltage too low	Check power line
	Contactor coil faulty HSW11 controller fault Start-up capacitor faulty (if featured) Compressor faulty Reversed phases (three-phase units only)	Replace the component
Insufficient capacity	Insufficient refrigerant Sizing of unit Operation outside recommended limits	Check
Compressor noisy	Liquid returning to compressor Inadequate fastening	Check
	Reversed phases (three-phase units only)	Reverse one phase
Noise and vibrations	Contact between metal bodies	Check
	Weak foundations	Repair
	Loose screws	Tighten screws
Protection devices trip and shut down the compressor	Excessive discharge pressure Low suction pressure Low voltage Electrical connections not sufficiently tight Operation outside permitted limits	Check
	Faulty operation of pressure switches	Replace the component
	Thermal protector tripped	Check supply voltage Check electrical insulation of windings

FAULT	CAUSE	SOLUTION
High discharge pressure (greater than 23 bars)*	High outside water temperature High utility water inlet temperature	Check
	Insufficient water flow-rate in utility heat exchanger (heating mode)	Check pump operation
	Faulty operation of outside heat exchanger control (pressure regulating valves)	Check
	Air in water circuit (heating mode)	Vent
	Excessive refrigerant content	Check
Low discharge pressure (less than 12 bars)*	Low utility water inlet temperature	Check
	Moisture in the refrigerant circuit (flow indicator - moisture yellow)	Empty and refill
	Faulty operation of outside heat exchanger control (pressure regulating valves)	Check
	Air in water circuit	Vent
	Insufficient refrigerant content	Check
High suction pressure (greater than 10 bars)*	High utility water inlet temperature Thermostatic expansion valve faulty or excessively open	Check
Low suction pressure (less than 3.2 bars)*	Low utility water inlet temperature Low outside water inlet temperature Thermostatic expansion valve faulty or blocked Blocked water filter Blocked plate heat exchanger	Check

*Values indicative only



Professional

Climaveneta Home System

Via Duca d'Aosta 121 - 31030 Mignagola (TV) - Italia
Tel. +39 0422 4131 - Fax +39 0422 413659