

# BAXI

# ECCO 3

GB

**High efficiency wall-mounted gas-fired boilers**

Instructions for Users and Installers

ES

**Caldera mural de gas de alto rendimiento**

Manual para el usuario y el instalador

RO

**Centrală murală cu gaz, de înalt randament**

Manual de instrucțiuni destinat utilizatorului și instalatorului

HU

**Magas hozamú fali gázkazán**

Felhasználói és szerelői kézikönyv

RU

**Высокопроизводительный настенный газовый котел**

Руководство по эксплуатации и монтажу

CE 0051



MP02

Dear Customer,

We are sure your new boiler will comply with all your requirements.

Purchasing one of the **BAXI** products satisfies your expectations: good functioning, simplicity and ease of use.

Do not dispose of this booklet without reading it: you can find here some very useful information, which will help you to run your boiler correctly and efficiently.

Do not leave any parts of the packaging (plastic bags, polystyrene, etc.) within children's reach as they are a potential source of danger.

**BAXI S.p.A.** declares that these models of boiler bear the CE mark in compliance with the basic requirements of the following Directives:

- Gas Directive 90/396/EEC
- Efficiency Directive 92/42/EEC
- Electromagnetic Compatibility Directive 2004/108/EEC
- Low Voltage Directive 2006/95/EC



## CONTENTS

### ISTRUZIONI PERTINENTI TO THE USER

1. Instructions prior to installation	3
2. Instructions prior to commissioning	3
3. Commissioning of the boiler	4
4. DHW temperature adjustment	4
5. Room temperature adjustment	5
6. Filling the boiler	5
7. Turning off the boiler	5
8. Gas change	5
9. Prolonged standstill of the system. Frost protection	6
10. Safety device indicators - activation	6
11. Servicing instructions	6

### ISTRUZIONI PERTINENTI TO THE INSTALLER

12. General information	7
13. Instructions prior to installation	7
14. Boiler installation	8
15. Boiler size	8
16. Installation of flue and air ducts	9
17. Connecting the mains supply	13
18. Fitting a room thermostat	13
19. Gas change modalities	14
20. Displaying electronic control card parameters on the boiler display ("INFO" mode)	16
21. Control and operation devices	17
22. Electronic board calibration	18
23. Positioning of the ignition and flame sensing electrode	18
24. Check of combustion parameters	18
25. Output / pump head performances	19
26. Connection of the external probe	19
27. Connection an external boiler	20
28. How to purge the DHW system from limestone deposits	21
29. How to disassemble the DHW heat exchanger	21
30. Cleaning the cold water filter	21
31. Boiler schematic	22-25
32. Illustrated wiring diagram	26-29
33. Technical data	30



**BAXI S.p.A.**, a leading European manufacturer of hi-tech boilers and heating systems, has developed CSQ-certified quality management (ISO 9001), environmental (ISO 14001) and health and safety (OHSAS 18001) systems. This means that BAXI S.p.A. includes among its objectives the safeguard of the environment, the reliability and quality of its products, and the health and safety of its employees.  
Through its organisation, the company is constantly committed to implementing and improving these aspects in favour of customer satisfaction.



# 1. INSTRUCTIONS PRIOR TO INSTALLATION

This boiler is designed to heat water at a lower than boiling temperature at atmospheric pressure. The boiler must be connected to a central heating system and to a domestic hot water supply system in compliance with its performances and output power.

Have the boiler installed by a Qualified Service Engineer and ensure the following operations are accomplished:

- a) careful checking that the boiler is fit for operation with the type of gas available. For more details see the notice on the packaging and the label on the appliance itself.
- b) careful checking that the flue terminal draft is appropriate; that the terminal is not obstructed and that no other appliance exhaust gases are expelled through the same flue duct, unless the flue is especially designed to collect the exhaust gas coming from more than one appliance, in conformity with the laws and regulations in force.
- c) careful checking that, in case the flue has been connected to pre-existing flue ducts, thorough cleaning has been carried out in that residual combustion products may come off during operation of the boiler and obstruct the flue duct.
- d) to ensure correct operation of the appliance and avoid invalidating the guarantee, observe the following precautions:

## 1. Hot water circuit:

- 1.1. If the water hardness is greater than 20 °F (1 °F = 10 mg calcium carbonate per litre of water) a polyphosphate or comparable treatment system responding to current regulations.
- 1.2. Domestic Hot Water circuit must be thoroughly flushed after the installation of the appliance and before its use.
- 1.3. The materials used for the domestic hot water circuit of the product comply with Directive 98/83/EC.

## 2. Heating circuit

### 2.1. new system

Before proceeding with installation of the boiler, the system must be cleaned and flushed out thoroughly to eliminate residual thread-cutting swarf, solder and solvents if any, using suitable proprietary products.

To avoid damaging metal, plastic and rubber parts, use only neutral cleaners, i.e. non-acid and non alkaline. The recommended products for cleaning are:

SENTINEL X300 or X400 and FERNOX heating circuit restore. To use this product proceeding strictly in accordance with the maker's directions.

### 2.2. existing system

Before proceeding with installation of the boiler, the system must be cleaned and flushed out to remove sludge and contaminants, using suitable proprietary products as described in section 2.1.

To avoid damaging metal, plastic and rubber parts, use only neutral cleaners, i.e. non-acid and non-alkaline such as SENTINEL X100 and FERNOX heating circuit protective. To use this product proceeding strictly in accordance with the maker's directions.

Remember that the presence of foreign matter in the heating system can adversely affect the operation of the boiler (e.g. overheating and noisy operation of the heat exchanger).

---

**Failure to observe the above will render the guarantee null and void.**

---

# 2. INSTRUCTIONS PRIOR TO COMMISSIONING

Initial lighting of the boiler must be carried out by a licensed technician. Ensure the following operations are carried out:

- a) compliance of boiler parameters with (electricity, water, gas) supply systems settings.
- b) compliance of installation with the laws and regulations in force.
- c) appropriate connection to the power supply and grounding of the appliance.

Failure to observe the above will render the guarantee null and void.

Prior to commissioning remove the protective plastic coating from the unit. Do not use any tools or abrasive detergents as you may spoil the painted surfaces.

---

***The instructions shall state the substance of the following:***

***This appliance is not intended for use by persons (including children) with reduced physical, sensory or mental capabilities, or lack of experience and knowledge, unless they have been given supervision or instruction concerning use of the appliance by a person responsible for their safety.***

***Children should be supervised to ensure that they do not play with the appliance.***

---

### 3. COMMISSIONING OF THE BOILER









To correctly light the burner proceed as follows:

- 1) provide power supply to the boiler;
- 2) open the gas cock;
- 3) turn the selector switch (Figure 2) to set the boiler on summertime (☀️) or wintertime (❄️) operation;
- 4) turn the central heating (2) and domestic hot water (1) adjusting controls in order to light the main burner.

To increase temperature values turn the control clockwise and anticlockwise to decrease it.

When on summertime operation (☀️) the main burner and the pump will start running only when there is a call for hot water.

**LEGEND:**

-  Operating in Central Heating mode (CH)
-  Flame present (burner switch on)
-  Loss of flame (burner off)
-  Operating in Domestic Hot Water mode (D.H.W.)
-  Generic ERROR
-  RESET
-  Water pressure LOW
-  Numeric signalling (temperature, error codes, etc)

① Domestic hot water (D.H.W.) control knob

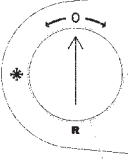

② Central heating (C.H.) control knob

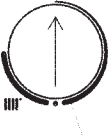

③ Selector (figure 2)

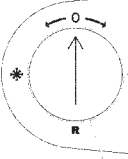

④ Display



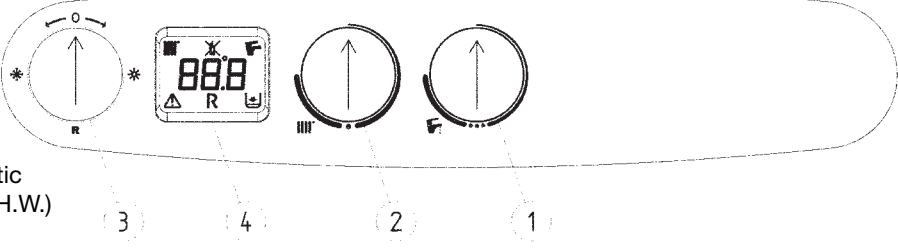

**Warning:** During initial lighting, until the air contained in the gas pipes is not released, the burner may fail to light immediately and that may cause a 'blockage' of the boiler. Under such circumstances we recommend you repeat the ignition procedure until gas is delivered to the burner, and set knob to (R - RESET) for at least 2 second.

0605\_2201 / CG\_1805

Figure 1

#### Summer / Winter / Reset / OFF selector positions

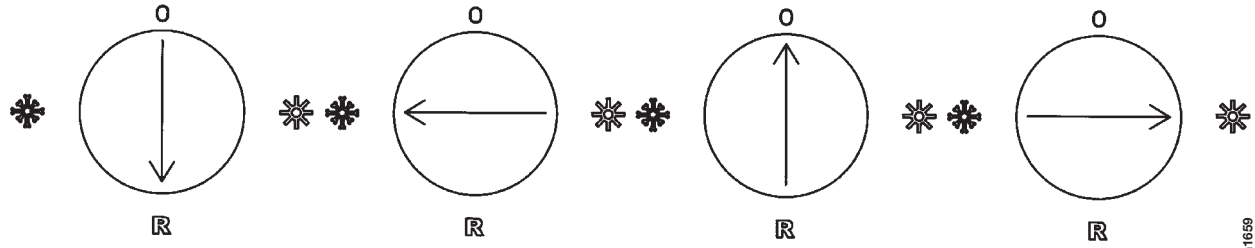

Reset

Winter

OFF

Summer

0603\_1109/CC1659

Figure 2

### 4. DHW TEMPERATURE ADJUSTMENT

The gas valve is provided with an electronic flame-modulating function, which operates depending on the DHW temperature adjusting control (1) settings and on the quantity of water drawn from the taps.

This electronic device allows to keep the water coming out of the boiler at a constant temperature also when small quantities of water are drawn.

During a domestic hot water request, the display shows a domestic hot water (D.H.W.) temperature.

To increase temperature values turn the control clockwise and anticlockwise to decrease it.

## 5. ROOM TEMPERATURE ADJUSTMENT

The system must be equipped with a room thermostat (see the relevant regulations) to control the temperature in the rooms.

In case there is no room thermostat, during initial lighting, it will be possible to control the room temperature by turning control (2).

During a central heating mode, the display shows a central heating (C.H.) flow temperature.

To increase temperature values turn the control clockwise and anticlockwise to decrease it. Electronic modulation of the flame will enable the boiler to reach the set temperature by adapting the gas supply to the burner to the actual heat exchange demand.

## 6. FILLING THE BOILER

Important: Regularly check that the pressure displayed by the pressure gauge is 0.7 to 1.5 bar, with boiler not operating. In case of overpressure, open the boiler drain valve (Figure 3).

In case the pressure is lower open the boiler filling tap (Figure 3).

We recommend you open the tap very slowly in order to let off the air.

During this operation, the Summer/Winter selector (Figure 2) must be in the OFF position (0).

**NOTE:** In case pressure drops occur frequently have the boiler checked by a Qualified Service Engineer.

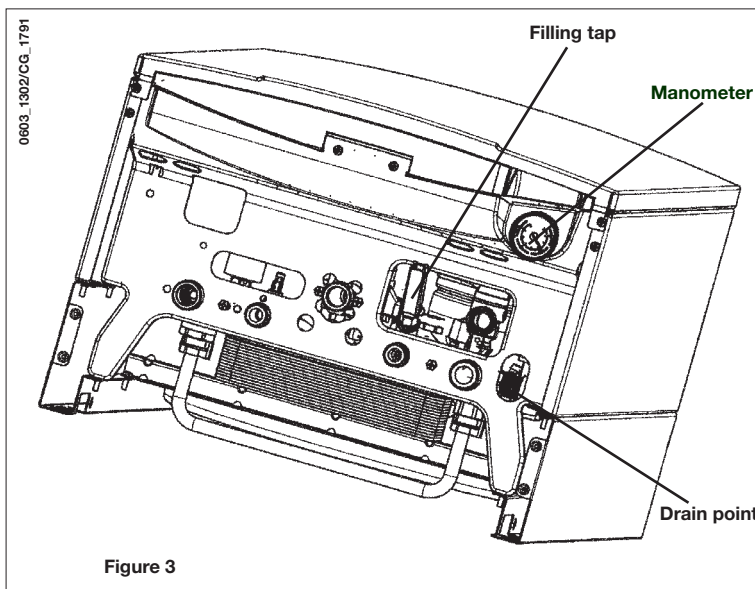

The boiler is supplied with a hydraulic pressure sensor, which blocks the boiler in case water is lacking.

## 7. TURNING OFF THE BOILER

The electric supply to the boiler must be removed in order to switch it off. With the selector in O position (off – figure 2), the gas boiler remain switched off, the display (4 – figure 1) reads out “OFF” but the main board is still supplied and the Frost protection function is activated.

**NOTE:** with the selector in “0” position and external probe connected, the display carries out the actual value of the external temperature.

## 8. GAS CHANGE

These boilers set for natural gas can be converted to work with **LPG**. Any gas change must be effected by a Qualified Service Engineer.

## 9. PROLONGED STANDSTILL OF THE SYSTEM. FROST PROTECTION

We recommend you avoid draining the whole system as water replacements engender purposeless and harmful limestone deposits inside the boiler and on the heating elements. In case the boiler is not operated during wintertime and is therefore exposed to danger of frost we suggest you add some specific-purpose anti-freeze to the water contained in the system (e.g.: propylene glycole coupled with corrosion and scaling inhibitors).

The electronic management of boilers includes a “frost protection” function in the central heating system which operates the burner to reach a heating flow temperature of 30° C when the system heating flow temperature drops below 5°C.

The frost protection function is enabled if:

- \* electrical supply to the boiler is on;
- \* the gas service cock is open;
- \* the system pressure is as required;
- \* the boiler is not blocked.

## 10. SAFETY DEVICE INDICATORS - ACTIVATION

If a fault occurs, the display reads out an error message identifying it (es. E 01):

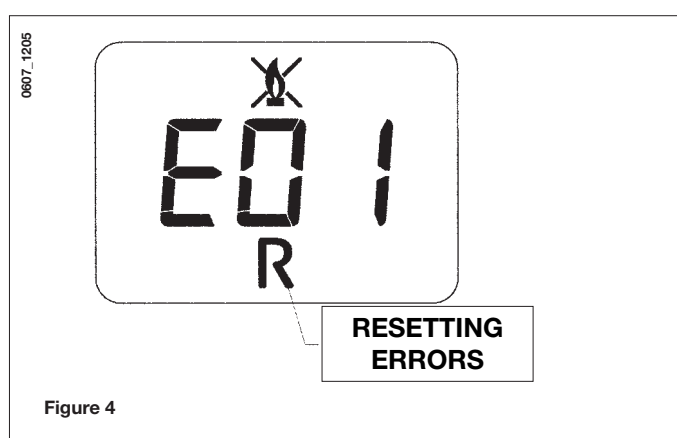

To RESET the gas boiler, turn selector (Figure 2) to “R” for at least 2 seconds. If the fault persists, call an authorised service centre.

**Note:** It is possible to carry out n° 5 relighting attempts in a row, after which the RESET function is disabled and the gas boiler still blocked.

To carry out a new RESET attempt, turn the selector (figure 2) in OFF position for at least 2 seconds.

Error code	Description of FAULTS	Corrective action
E01	Gas supply fault	Turn selector (figure 2) to “R” for at least 2 seconds. If this fault persists, call an authorised service centre.
E02	Safety thermostat sensor tripped	Turn selector (figure 2) to “R” for at least 2 seconds. If this fault persists, call an authorised service centre.
E03	Flue thermostat sensor tripped / Flue pressure switch tripped	Call an authorised service centre.
E05	Central heating NTC sensor fault	Call an authorised service centre.
E06	Domestic Hot Water NTC sensor fault	Call an authorised service centre.
E10	Water pressure LOW	Check that the pressure in the system is as specified. See section 6. If this fault persists, call an authorised service centre.
E25	Boiler max temperature exceeded(probable pump jammed)	Call an authorised service centre.
E35	Fault flame (parasitic flame)	Turn selector (figure 2) to “R” for at least 2 seconds. If this fault persists, call an authorised service centre.

**NOTE:** if a fault occurs, the display reads out an error code flashing together with background light.

## 11. SERVICING INSTRUCTIONS

To maintain efficient and safe operation of your boiler have it checked by a Qualified Service Engineer at the end of every operating period.

Careful servicing will ensure economical operation of the system.

Do not clean the outer casing of the appliance with abrasive, aggressive and/or easily flammable cleaners (i.e.: gasoline, alcohol, and so on). Always isolate the electrical supply to the appliance before cleaning it (see section 7 “Turning off the boiler”).

## 12. GENERAL INFORMATION

**Warning:** When the selector switch (figure 2) is set on Wintertime operation (❄️), it may be necessary to wait some minutes for the relight of the boiler, at each intervention of the central heating temperature adjusting control (2-figura 1).

**No waiting is needed when the boiler is in the DHW mode on models with this option.**

To relight the main burner immediately place the selector switch (figure 2) on 0 position and then again on ❄️ position.

The following remarks and instructions are addressed to Service Engineers to help them carry out a faultless installation. Instructions regarding lighting and operation of the boiler are contained in the 'Instructions pertaining to the user' section. Note that installation, maintenance and operation of the domestic gas appliances must be performed exclusively by qualified personnel in compliance with current standards.

Please note the following:

- \* This boiler can be connected to any type of double- or single feeding pipe convector plates, radiators, thermoconvectors. Design the system sections as usual though taking into account the available output / pump head performances, as shown in section 26.
- \* Do not leave any packaging components (plastic bags, polystyrene, etc.) within children's reach as they are a potential source of danger.
- \* Initial lighting of the boiler must be effected by a Qualified Service Engineer.

Failure to observe the above will render the guarantee null and void.

## 13. INSTRUCTIONS PRIOR TO INSTALLATION

This boiler is designed to heat water at a lower than boiling temperature at atmospheric pressure. The boiler must be connected to a central heating system and to a domestic hot water supply system in compliance with its performances and output power.

Have the boiler installed by a Qualified Service Engineer and ensure the following operations are accomplished:

- a) careful checking that the boiler is fit for operation with the type of gas available. For more details see the notice on the packaging and the label on the appliance itself.
- b) careful checking that the flue terminal draft is appropriate; that the terminal is not obstructed and that no other appliance exhaust gases are expelled through the same flue duct, unless the flue is especially designed to collect the exhaust gas coming from more than one appliance, in conformity with the laws and regulations in force.
- c) careful checking that, in case the flue has been connected to pre-existing flue ducts, thorough cleaning has been carried out in that residual combustion products may come off during operation of the boiler and obstruct the flue duct.

To ensure correct operation of the appliance and avoid invalidating the guarantee, observe the following precautions:

### 1. Hot water circuit:

- 1.1. If the water hardness is greater than 20 °F (1 °F = 10 mg calcium carbonate per litre of water) a polyphosphate or comparable treatment system responding to current regulations.
- 1.2. Domestic Hot Water circuit must be thoroughly flushed after the installation of the appliance and before its use.
- 1.3. The materials used for the domestic hot water circuit of the product comply with Directive 98/83/EC.

### 2. Heating circuit

#### 2.1. new system

Before proceeding with installation of the boiler, the system must be cleaned and flushed out thoroughly to eliminate residual thread-cutting swarf, solder and solvents if any, using suitable proprietary products.

To avoid damaging metal, plastic and rubber parts, use only neutral cleaners, i.e. non-acid and non alkaline. The recommended products for cleaning are:

SENTINEL X300 or X400 and FERNOX heating circuit restore. To use this product proceeding strictly in accordance with the maker's directions.

#### 2.2. existing system

Before proceeding with installation of the boiler, the system must be cleaned and flushed out to remove sludge and contaminants, using suitable proprietary products as described in section 2.1.

To avoid damaging metal, plastic and rubber parts, use only neutral cleaners, i.e. non-acid and non-alkaline such as SENTINEL X100 and FERNOX heating circuit protective. To use this product proceeding strictly in accordance with the maker's directions.

Remember that the presence of foreign matter in the heating system can adversely affect the operation of the boiler (e.g. overheating and noisy operation of the heat exchanger).

**Failure to observe the above will render the guarantee null and void.**



# 14. BOILER INSTALLATION

Decide upon the boiler location, then tape the template on the wall. Connect the pipework to the gas and water inlets prearranged on the template lower bar. We suggest you fit two G3/4 stop cocks (available on demand) on the central heating system flow and return pipework; the cocks will allow to carry out important operations on the system without draining it completely. If you are either installing the boiler on a pre-existent system or substituting it, we suggest you also fit settling tank on the system return pipework and under the boiler to collect the deposits and scaling which may remain and be circulated in the system after the purge.

When the boiler is fixed on the template connect the flue and air ducts (fittings supplied by the manufacturer) according to the instructions given in the following sections.

When installing the **240 i - 1.240 i** models (boilers with natural draught), make the connection to the flue using a metal pipe which will provide resistance over time to the normal mechanical stresses, heat and the effects of the combustion products and any condensation they form.

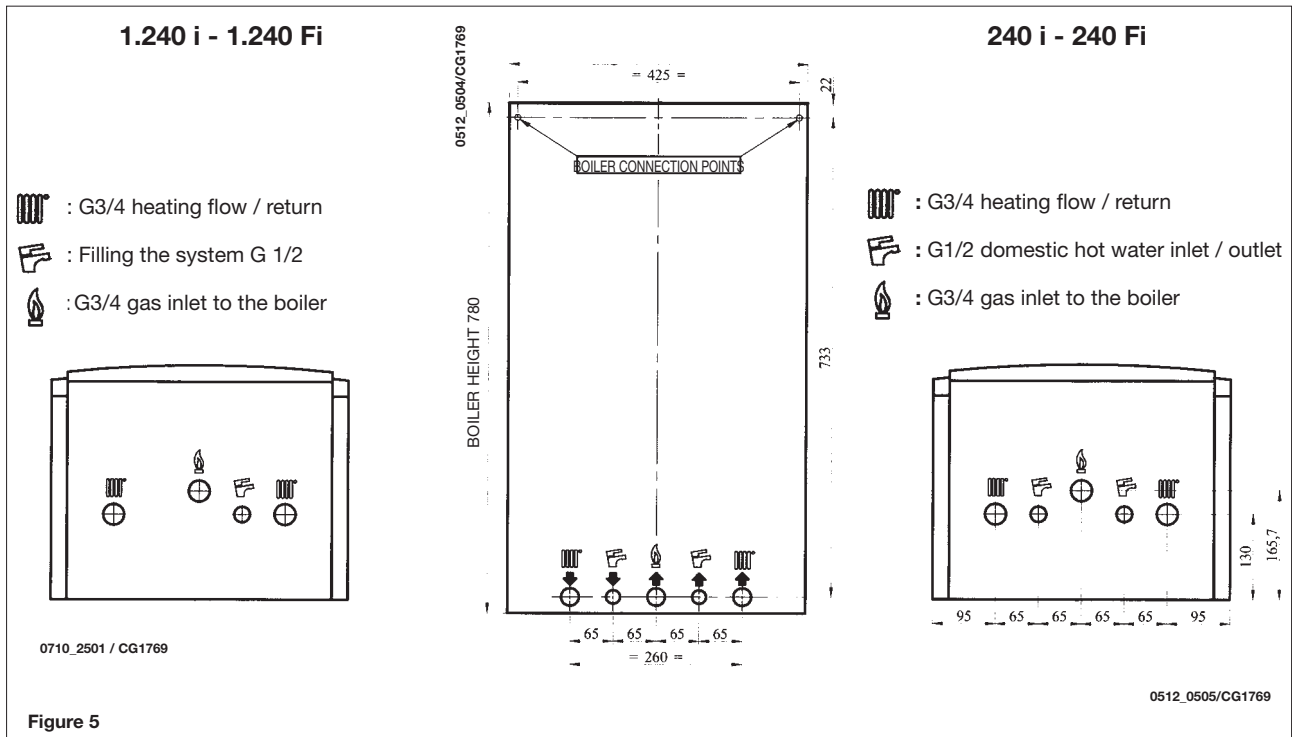

# 15. BOILER SIZE

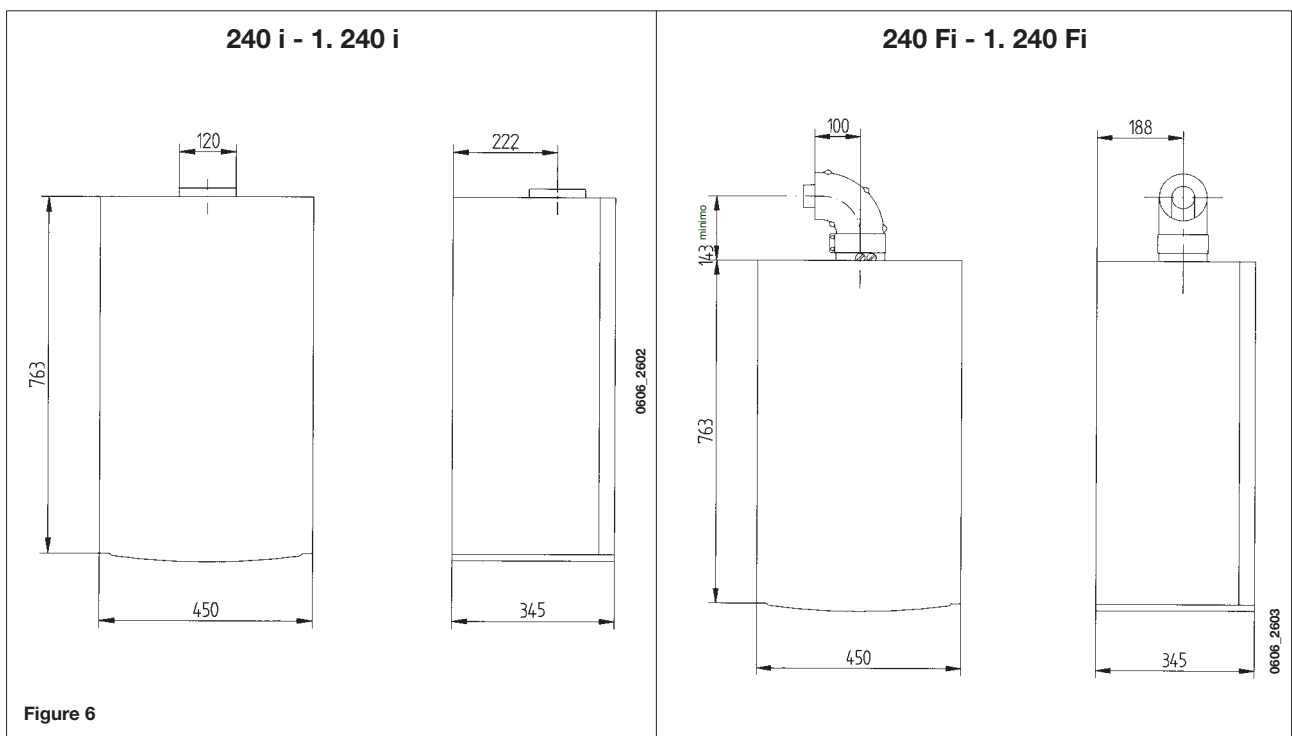



# 16. INSTALLATION OF FLUE AND AIR DUCTS

## Models 240 Fi - 1.240 Fi

We guarantee ease and flexibility of installation for a gas-fired forced draught boiler thanks to the fittings and fixtures supplied (described below).

The boiler is especially designed for connection to an exhaust flue / air ducting, with either coaxial, vertical or horizontal terminal. By means of a splitting kit a two-pipe system may also be installed.

**Exclusively install fittings supplied by the manufacturer.**

***WARNING : To guarantee more operating insurance it is necessary to assure the flue pipes to the wall using the apposite clamps.***

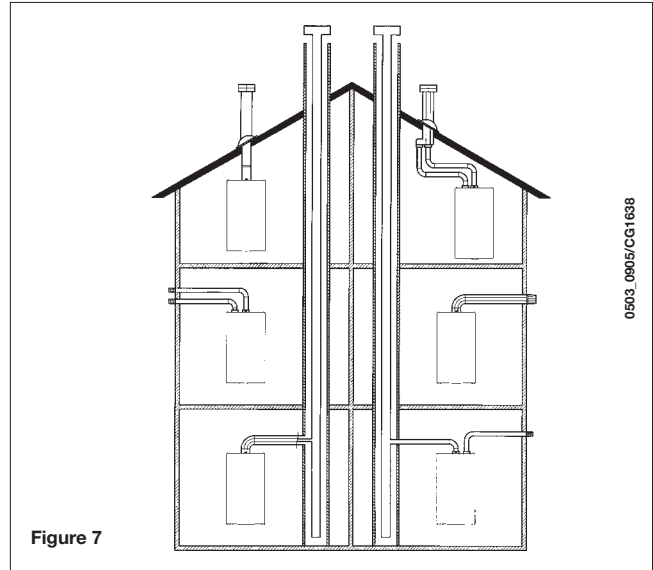

Figure 7

### ... COAXIAL FLUE - AIR DUCT (CONCENTRIC)

This type of duct allows to disengage exhaust gases and to draw combustion air both outside the building and in case a LAS flue is fitted.

The 90° coaxial bend allows to connect the boiler to a flue-air duct in any direction as it can rotate by 360°. It can moreover be used as a supplementary bend and be coupled with a coaxial duct or a 45° bend.

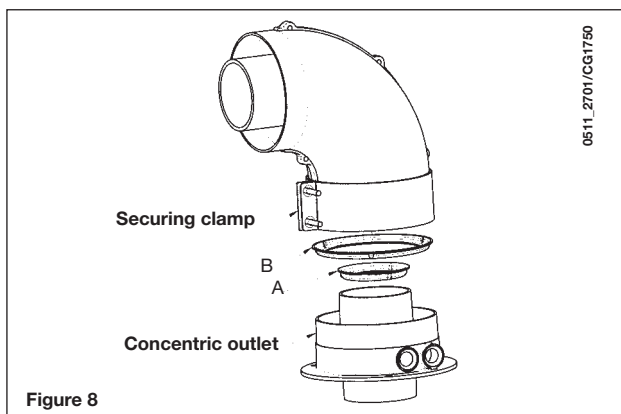

Figure 8

If the flue outlet is placed outside, the flue-air ducting must protrude at least 18mm out of the wall to allow aluminium weathering tile to be fitted and sealed to avoid water leakages. Ensure a minimum downward slope of 1 cm towards the outside per each metre of duct length.

- A 90° bend reduces the total duct length by 1 metre.
- A 45° bend reduces the total duct length by 0.5 metre.

**The first 90° bend is not included in the maximum available length.**

Boiler model	Length (m)	Air suction RESTRICTOR Ⓑ	Flue RESTRICTOR Ⓐ
240 Fi 1.240 Fi	0 ÷ 1	Yes	Yes
	1 ÷ 2		No
	2 ÷ 5	No	No
280 Fi	0 ÷ 1	No	Yes
	1 ÷ 2	Yes	No
	2 ÷ 4	No	No

## 16.1 HORIZONTAL FLUE TERMINAL INSTALLATION OPTIONS

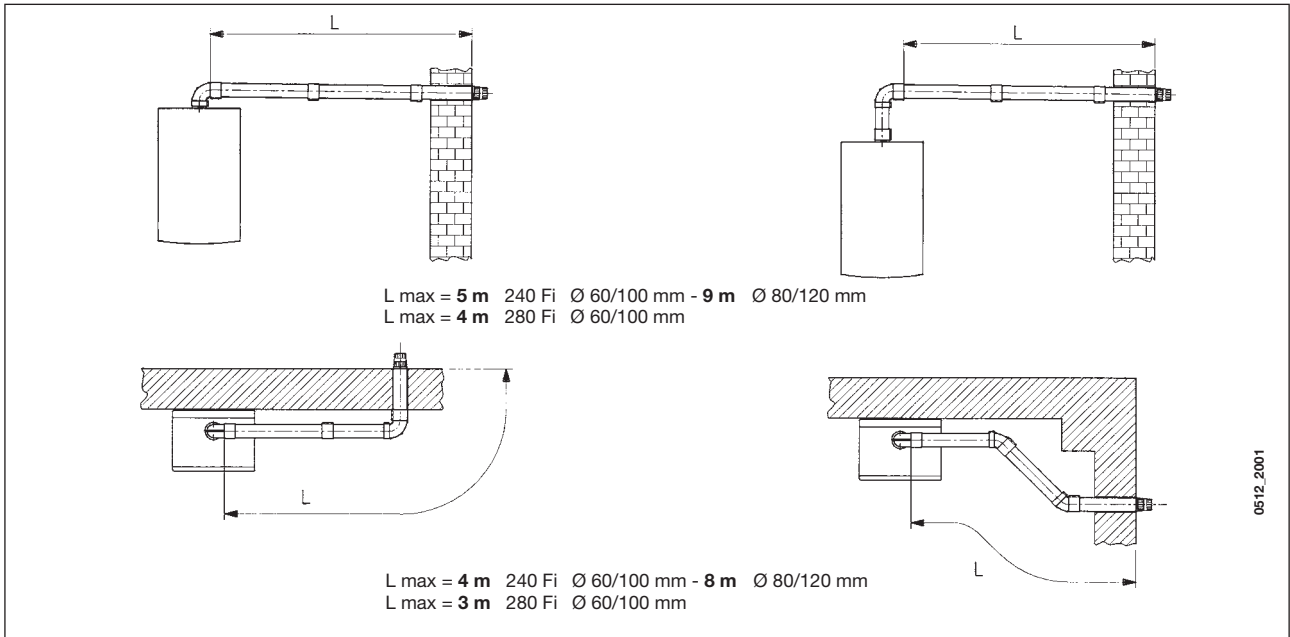

## 16.2 LAS FLUE DUCT INSTALLATION OPTIONS

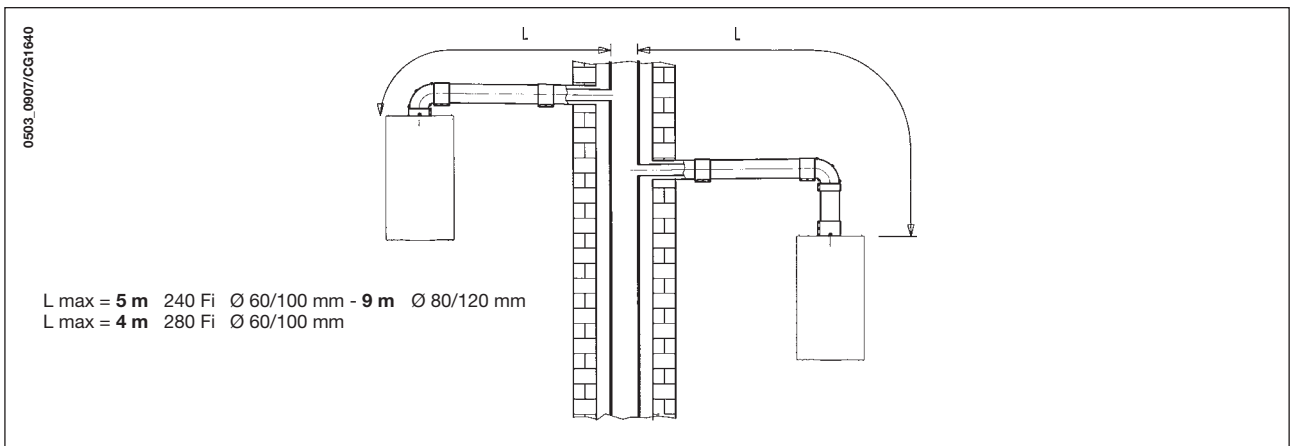

## 16.3 VERTICAL FLUE TERMINAL INSTALLATION OPTIONS

This type of installation can be carried out both on a flat or pitched roof by fitting a terminal, an appropriate weathering tile and sleeve, (supplementary fittings supplied on demand).

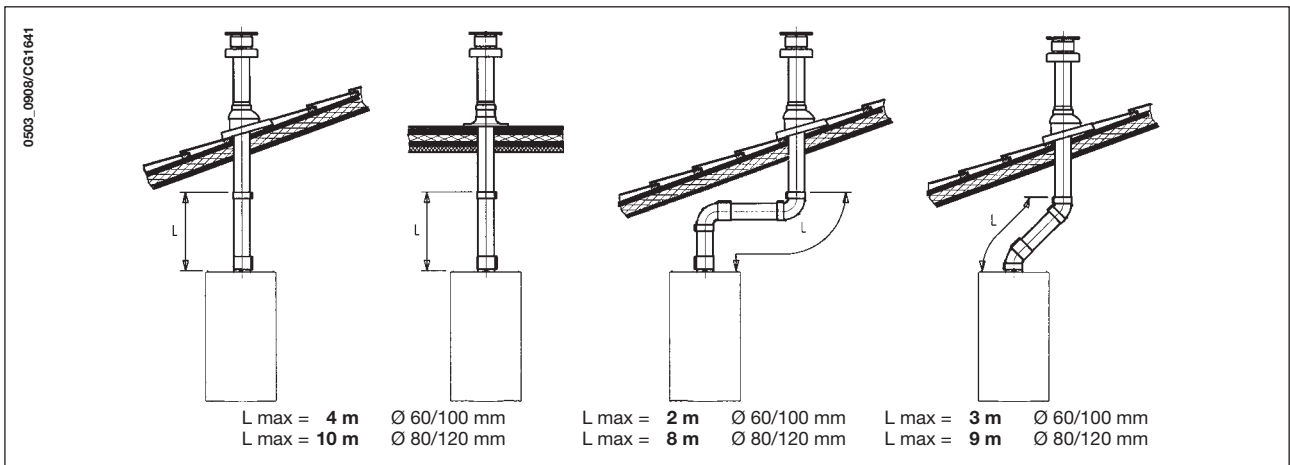

For detailed instructions concerning the installation of fittings refer to the technical data accompanying the fittings.

### ... SEPARATED FLUE-AIR DUCTING

This type of ducting allows to disengage exhaust flue gases both outside the building and into single flue ducts. Comburant air may be drawn in at a different site from where the flue terminal is located. The splitting kit consists of a flue duct adaptor (100/80) and of an air duct adaptor. For the air duct adaptor fit the screws and seals previously removed from the cap.

**The restrictor must be removed in the following cases**

Boiler model	(L1+L2)	Air suction coupling position	Flue RESTRICTOR Ⓐ	CO2 %	
				G20	G31
240 Fi 1.240 Fi	0 ÷ 4	3	Yes	6,4	7,3
	4 ÷ 15	1	No		
	15 ÷ 25	2			
	25 ÷ 40	3			
280 Fi	0 ÷ 2	1	No	7,4	8,4
	2 ÷ 10	2			
	10 ÷ 25	3			

**The first 90° bend is not included in the maximum available length.**

The 90° bend allows to connect the boiler to flue-air ducting regardless of direction as it can be rotated by 360°. It can moreover be used as a supplementary bend to be coupled with the duct or with a 45° bend.

- **A 90° bend reduces the total duct length by 0.5 metre.**
- **A 45° bend reduces the total duct length by 0.25 metre.**

### Split flue air control adjustment

The adjustment of this control is required to optimise performance and combustion parameters. The air suction coupling can be rotated to adjust excess air according to the total length of the flue and intake ducts for the combustion air. Turn this control to increase or decrease excess combustion air (figure 9):

To improve optimisation a combustion product analyser can be used to measure the CO<sub>2</sub> contents of the flue at maximum heat output, gradually adjusting air to obtain the CO<sub>2</sub> reading in the table below, if the analysis shows a lower value.

To properly install this device, also refer to the technical data accompanying the fitting.

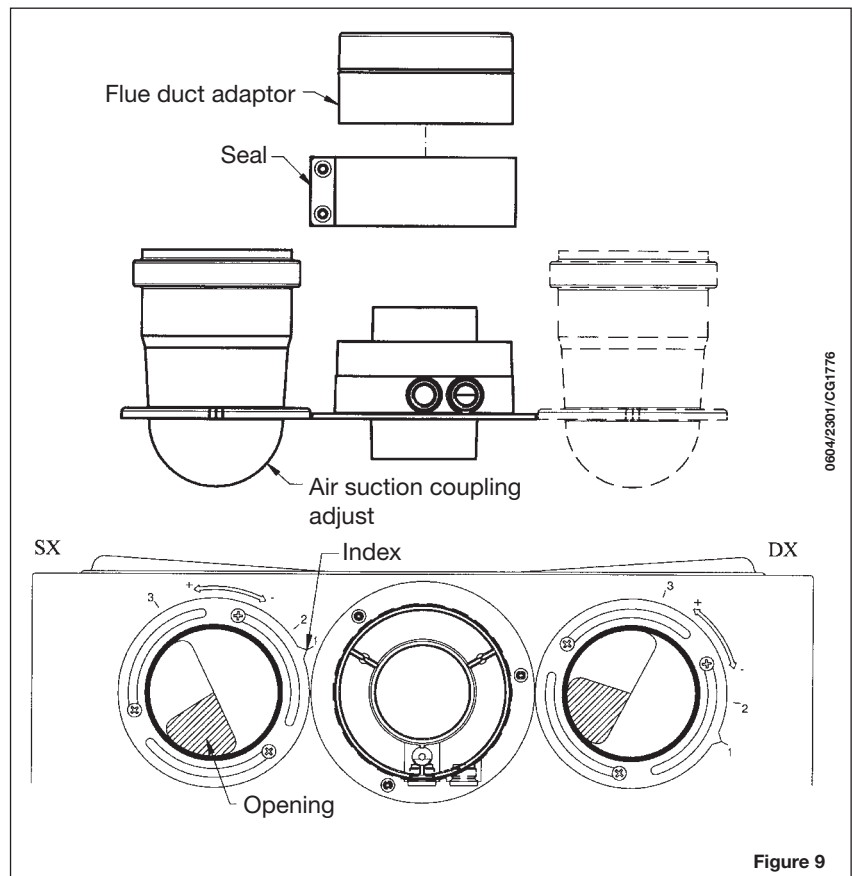
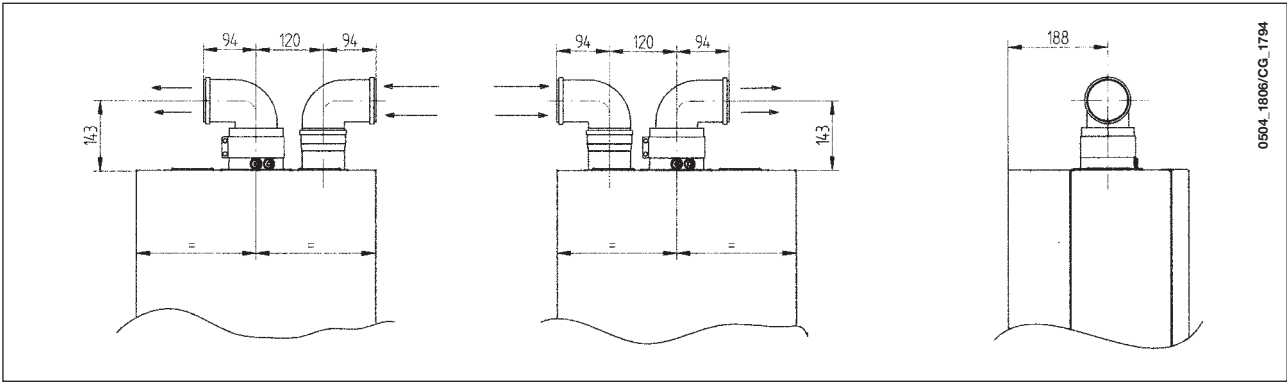

Figure 9

## 16.4 SPLIT FLUE OVERALL DIMENSIONS



## 16.5 SEPARATED HORIZONTAL FLUE TERMINALS INSTALLATION OPTIONS

**IMPORTANT:** Ensure a minimum downward slope of 1 cm toward the outside per each metre of duct length. In the event of installation of the condensate collection kit, the angle of the drain duct must be directed towards the boiler.

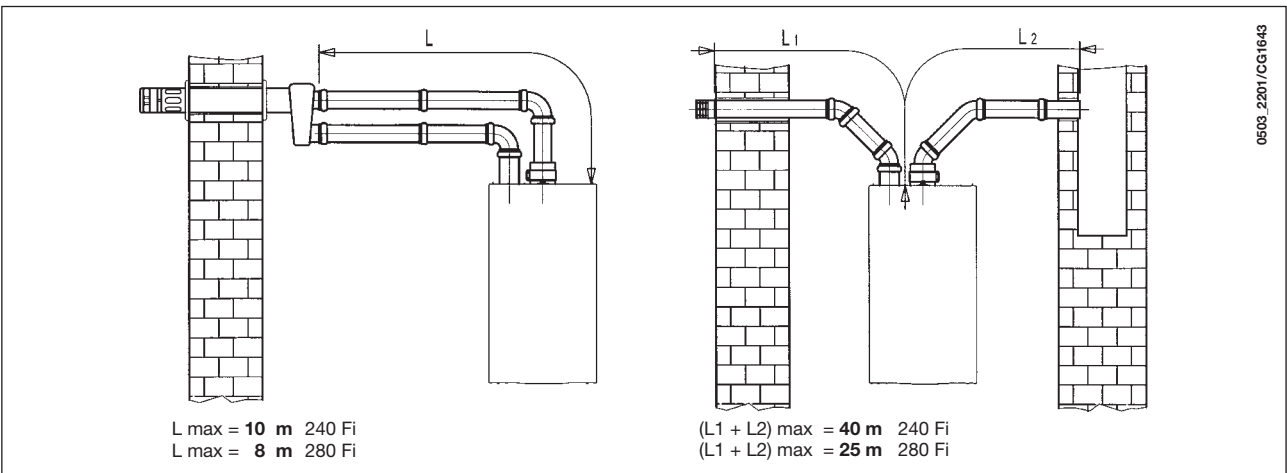

**NB:** For C52 types, terminals for combustion air suction and combustion product extraction must never be fitted on opposite walls of the building.

The maximum length of the suction duct for type C52 must be 10 metres.

If the flue duct exceeds 6 m, the condensate collection kit (supplied as an accessory) must be fitted close to the boiler.

## 16.6 SEPARATED VERTICAL FLUE TERMINALS INSTALLATION OPTIONS

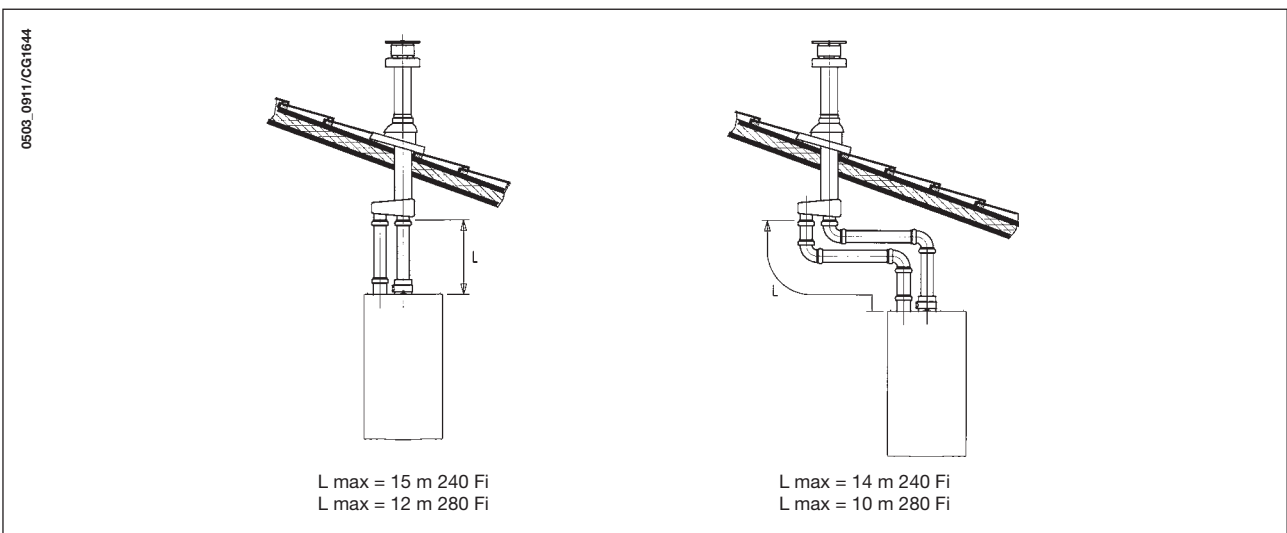

**Important:** if fitting a single exhaust flue duct, ensure it is adequately insulated (e.g.: with glass wool) wherever the duct passes through building walls.

For detailed instructions concerning the installation of fittings refer to the technical data accompanying the fittings.

## 17. CONNECTING THE MAINS SUPPLY

Electrical safety of the appliance is only guaranteed by correct grounding, in compliance with the applicable laws and regulations.

Connect the boiler to a 230V monophase + ground power supply by means of the three-pin cable supplied with it and make sure you connect polarities correctly.

**Use a double-pole switch with a contact separation of at least 3mm in both poles.**

In case you replace the power supply cable fit a HAR H05 VV-F' 3x0.75mm<sup>2</sup> cable with an 8mm diameter max.

### ...access to the power supply terminal block

- isolate the electrical supply to the boiler by the double-pole switch;
- unscrew the two screws securing the control board to the boiler;
- rotate the control board;
- unscrew the lid and gain access to the wiring (Figure 10).

A 2A fast-blowing fuse is incorporated in the power supply terminal block (to check or replace the fuse, pull out the black fuse carrier).

**IMPORTANT:** be sure to connect polarities correctly **L** (LIVE) - **N** (NEUTRAL).

(L) = **Live** (brown)

(N) = **Neutral** (blue)

⊕ = **Ground** (yellow/green)

(1) (2) = **Room thermostat terminals**

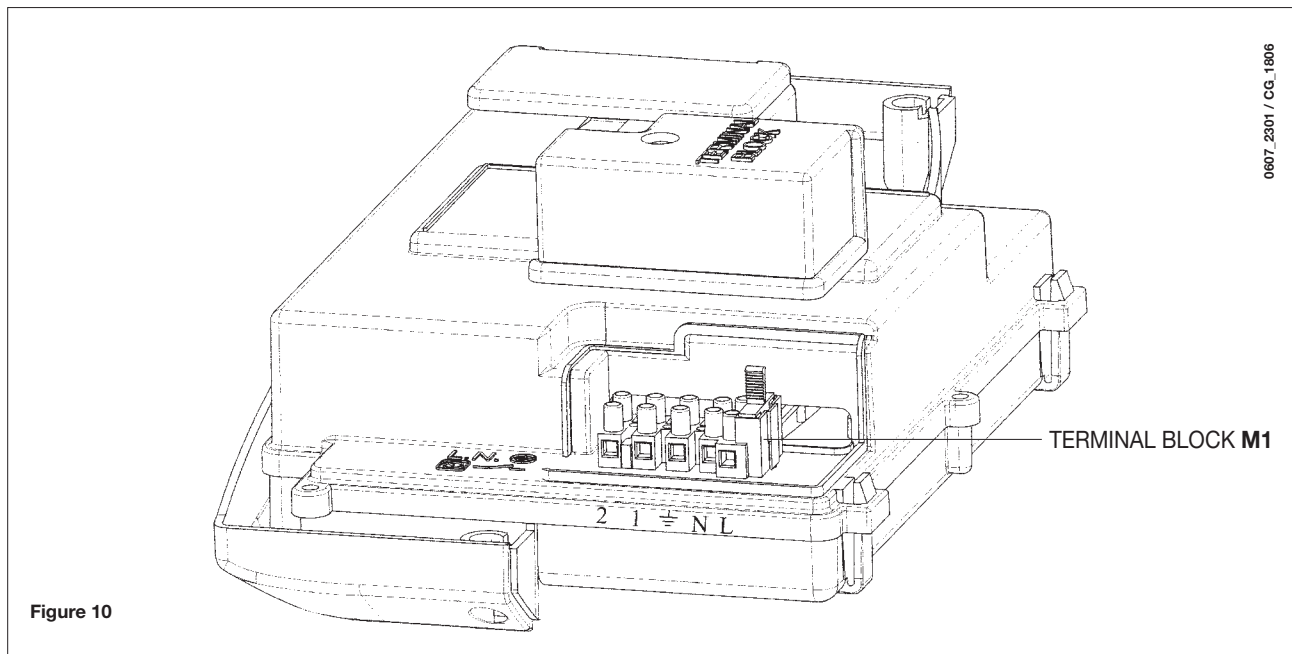

## 18. FITTING A ROOM THERMOSTAT

- gain access to the power supply terminal block (Figure 10) as described in the previous section;
- remove the jumper placed on terminals (1) and (2);
- insert the duplex cable through the core hitch and connect it to the two terminals.

## 19. GAS CHANGE MODALITIES

A Qualified Service Engineer may adapt this boiler to operate with natural gas (G. 20) or with liquid gas (G. 31).

A Qualified Service Engineer may adapt this boiler to operate with natural gas (G. 20) or with liquid gas (G. 31).

The procedure for calibrating the pressure regulator may vary according to the type of gas valve fitted (HONEYWELL or SIT; see figure 12).

Carry out the following operations in the given sequence:

- A) substitute the main burner injectors;
- B) change the modulator voltage;
- C) proceed with a new max. and min. setting of the pressure adjusting device.

### A) Substitute the main burner injectors

- carefully pull the main burner off its seat;
- substitute the main burner injectors and make sure you tighten them to avoid leakage. The nozzle diameters are specified in table 2.

### B) Change the modulator voltage

- remove the 2 screws securing the control board cover and hinge it upward;
- set the jumper or the switch, according to the type of gas used, as described in the chapter 22.

### C) Pressure adjusting device setting

- connect the positive pressure test point of a differential (possibly water-operated) manometer to the gas valve pressure test point (Pb) (Figure 12); connect, for sealed chamber models only, the negative pressure test point of the manometer to a "T" fitting in order to join the boiler adjusting outlet, the gas valve adjusting outlet (Pc) and the manometer. (The same measurement can be carried out by connecting the manometer to the pressure test point (Pb) after removing the sealed chamber front panel);

If you measure the pressure of burners in a different way you may obtain an altered result in that the low pressure created in the sealed chamber by the fan would not be taken into account.

#### C1) Adjustment to rated output

- open the gas tap and rotate knob (Figure 12) to set the boiler to the Winter setting (❄️);
- open a hot water tap to reach a minimum 10 l/minute flow rate or ensure that maximum heating requirements are set;
- remove the modulator cover;
- adjust the tube brass screw (a) Fig. 13 to obtain the pressure settings shown at table 1;
- check that boiler feeding dynamic pressure, as measured at the inlet gas valve pressure test point (Pa) (Figure 12) is correct (37 mbar for LPG gas (G.31), 20 mbar for natural gas);

#### C2) Adjustment to reduced heat output

- disconnect the modulator feeding cable and unscrew the (b) Fig. 13 screw to reach the pressure setting corresponding to reduced heat output (see table 1);
- connect the cable again;
- fit the modulator cover and seal.

#### C3) Final checks

- apply the additional dataplate, specifying the type of gas and settings applied.

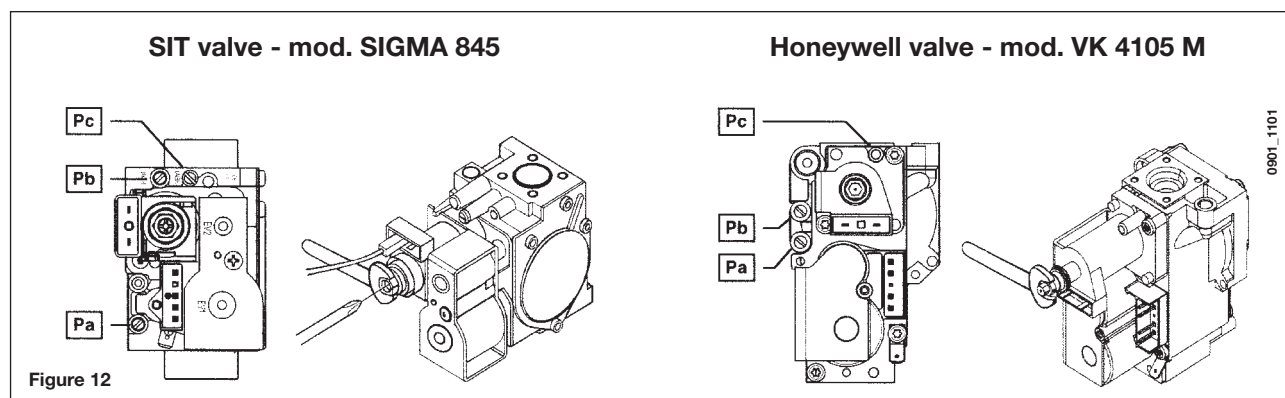

## Table of burner pressures

Gas used	240 i - 1.240 i		240 Fi		280 Fi	
	G20	G31	G20	G31	G20	G31
nozzle diameter (mm)	1,18	0,74	1,18	0,74	1,28	0,77
Burner pressure (mbar*) <b>REDUCED HEAT OUTPUT</b>	1,9	4,7	1,9	4,9	1,8	4,9
Burner pressure (mbar*) <b>NOMINAL HEAT OUTPUT</b>	10,0	26	11,3	29,4	11,3	31,0
no. of nozzles	15					

\* 1 mbar = 10,197 mm H<sub>2</sub>O

Table 1

Consumption 15°C-1013 mbar	240 i - 1.240 i		240 Fi		280 Fi	
	G20	G31	G20	G31	G20	G31
<b>Rated heat output</b>	2,78 m <sup>3</sup> /h	2,04 kg/h	2,73 m <sup>3</sup> /h	2,00 kg/h	3,18 m <sup>3</sup> /h	2,34 kg/h
<b>Reduced heat output</b>	1,12 m <sup>3</sup> /h	0,82 kg/h	1,12 m <sup>3</sup> /h	0,82 kg/h	1,26 m <sup>3</sup> /h	0,92 kg/h
<b>p.c.i.</b>	34,02 MJ/m <sup>3</sup>	46,30 MJ/kg	34,02 MJ/m <sup>3</sup>	46,30 MJ/kg	34,02 MJ/m <sup>3</sup>	46,30 MJ/kg

Table 2



## 20. DISPLAYING PARAMETERS ON THE DISPLAY ("INFO" MODE)

Proceed as follows to display boiler parameters on the front panel display:

**IMPORTANT:** the following operations (figure 14), it has to be carried out in fast sequence in a short time (~ 4 seconds) without making any break during the steps:

- 1) with the control knob (  ) *in any position* turns it fully anti-clockwise to the minimum value;
- 2) quickly turn control knob clockwise through about a  $\frac{1}{4}$  turn;
- 3) again turns the control knob fully anti-clockwise to its minimum value
- 4) then set back the control knob to its original position.

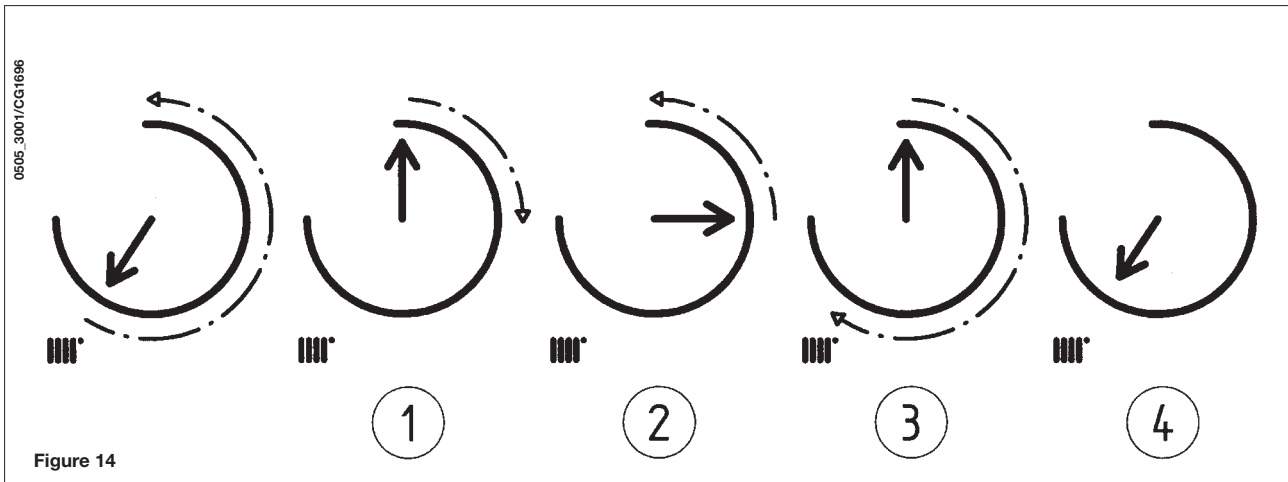

**Note:** In "INFO" mode, the display (4 - figure 1) alternates between the message "A00" and CH temperature.

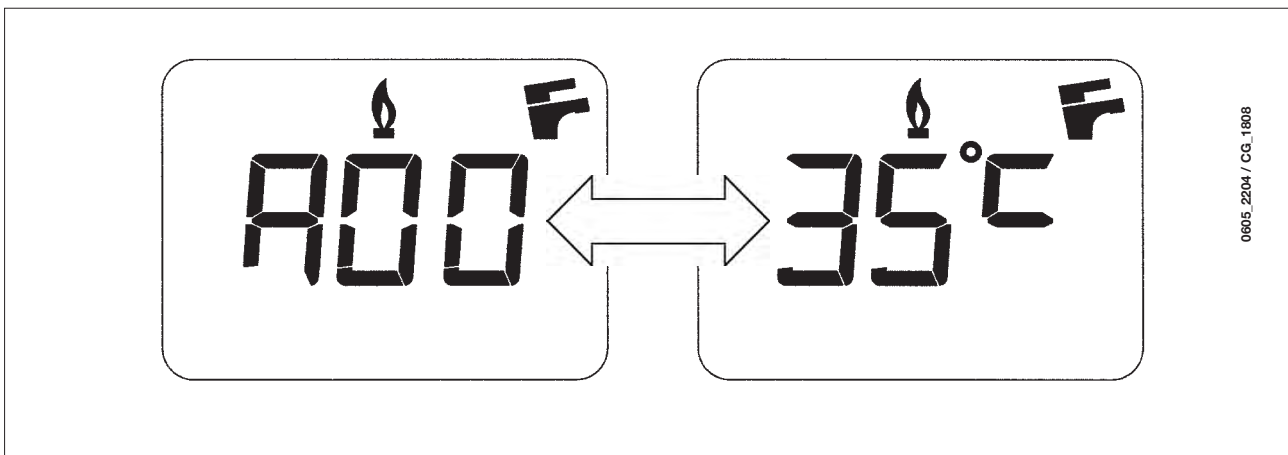

- turn the control knob (  ) to display the following informations:

- A00:** domestic hot water output temperature (°C);
- A01:** outdoor temperature (in °C) with outdoor sensor probe connected;
- A02:** the value (%) of the modulator current (100% = 230 mA NATURAL GAS - 100% = 310 mA LPG);
- A03:** heat output (%) power range (max R);
- A04:** central heating water output setpoint temperature (°C);
- A05:** central heating water output temperature (°C);
- A07:** valve ( $\mu$ A) of the ionization current.

**Note:** program lines from A06 - A08 - A09 are not used.

- "INFO" function remains active for 3 minutes. To exit "INFO" function before this time repeat the operation as described in points 1...4 or cutting OFF the power supply to the boiler.

## 21. CONTROL AND OPERATION DEVICES

The boiler has been designed in full compliance with European reference standards and in particular is equipped with the following:

- **Central heating temperature adjustment potentiometer ( IIII )**  
This potentiometer sets the central heating flow max. temperature. Its temperature range goes from 30 °C min. to 80 °C max. To increase the temperature turn knob (2 - figure 1) clockwise and anticlockwise to decrease it.
- **Domestic hot water temperature adjusting potentiometer ( F )**  
This potentiometer sets the domestic hot water max. temperature. Its temperature range goes from 35 °C min. to 60 °C max according to the water inlet flow rate.  
To increase the temperature turn knob (1 - figure 1) clockwise and anticlockwise to decrease it.  
**Note:** domestic hot water is guaranteed even if the NTC sensor is damaged. In this case, the temperature control is carried out by the boiler flow temperature.
- **Flue pressure switch for forced draught model (240 Fi - 1.240 Fi - 280 Fi)**  
This switch allows the burner to switch on provided the exhaust flue duct efficiency is perfect.  
In the event of one of the following faults:
  - the flue terminal is obstructed
  - the venturi is obstructed
  - the fan is blocked
  - the connection between the venturi and the air pressure switch is interrupted,the boiler will stay on stand-by and the display shows out error code E03 (see table on section 10).
- **Flue thermostat for natural draught (models 240 i - 1.240 i)**  
This device has a sensor positioned on the left section of the flue extraction hood and shuts off the gas flow to the burner if the flue duct is obstructed or in the event of draught failure.  
Under such conditions the boiler is blocked and the display shows E03 error (see section 10).  
To relight the main burner immediately, place the selector switch (figure 2) on "R" position for at least 2 seconds.

---

It is forbidden to disenable this safety device

---

- **Overheat safety thermostat**  
Thanks to a sensor placed on the heating flow, this thermostat interrupts the gas flow to the burner in case the water contained in the primary system has overheated. Under such conditions the boiler is blocked and relighting will only be possible after the cause of the anomaly has been removed.  
Turn the selector (figure 2) to (R) for at least 2 seconds to RESET normal operating conditions.

---

It is forbidden to disenable this safety device

---

- **Flame ionization detector**  
The flame sensing electrode, placed on the right of the burner, guarantees safety of operation in case of gas failure or incomplete interlighting of the burner. Under such conditions the boiler is blocked.  
Turn the selector (figure 2) to (R) for at least 2 seconds to RESET normal operating conditions.
- **Hydraulic pressure sensor**  
This device enables the main burner only to be switched on if the system pressure is over 0.5 bars.
- **Pump overrun for central heating circuit**  
The electronically-controlled supplementary running of the pump lasts 180 seconds, when the boiler is in the central heating mode, after the burner has switched off due to a room thermostat or intervention.
- **Pump overrun for domestic hot water circuit**  
The electronic control system keeps the pump operating for 30 seconds in domestic hot water mode after the D.H.W. sensor has switched off the burner.
- **Frost protection device (central heating and domestic hot water systems)**  
Boilers electronic management includes a "frost protection" function in the central heating system which operates the burner to reach a heating flow temperature of 30°C when the system heating flow temperature drops below 5 °C.  
This function is enabled when the boiler is connected to electrical supply, the gas supply is on and the system pressure is as required.
- **Lack of water circulation (probable pump jammed)**  
If the water inside the primary circuit doesn't circulate, the display shows E03 error (see section 10).
- **Anti-block pump function**  
In the event that no heat is required (during heating and/or sanitary mode), the pump will automatically start up and operate for one minute during the following 24 hours.  
This function is operative when the boiler is powered.
- **Three-way anti-blockage valve**  
In the case of no heat is request for a period of 24 hours the three way valve carries out a complete commutation.  
This function is operative when the boiler is powered.
- **Hydraulic safety valve (heating circuit)**  
This device is set to 3 bar and is used for the heating circuit.

---

The safety valve should be connected to a siphoned drain. Use as a means of draining the heating circuit is strictly prohibited.

---

## 22. ELECTRONIC BOARD CALIBRATION

When the jumper or the switch is in the **OFF** position (fig. 15a):

**MET** operation of the boiler with NATURAL gas  
**T.Risc** boiler heating temperature range **30 - 85°C**  
**T-off** 150-seconds heating stand-by time

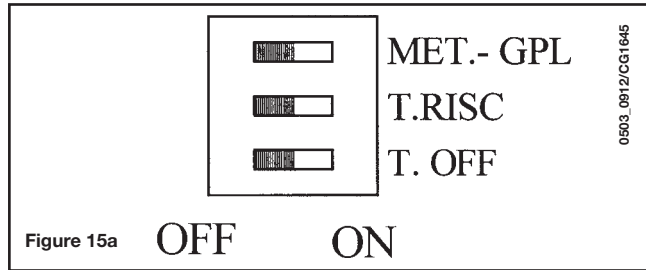

When the jumper or the switch is in the **ON** position (fig. 15b):

**GPL** operation of the boiler with LPG  
**T.Risc** boiler heating temperature range **30 - 45°C**  
**T-off** 30-seconds heating stand-by time

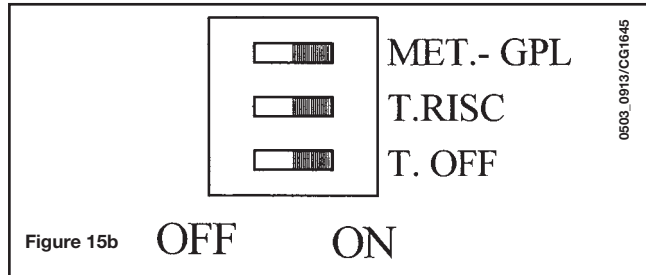

**NB.** Make sure that electrical power supply has been disconnected before making settings.

## 23. POSITIONING OF THE IGNITION AND FLAME SENSING ELECTRODE

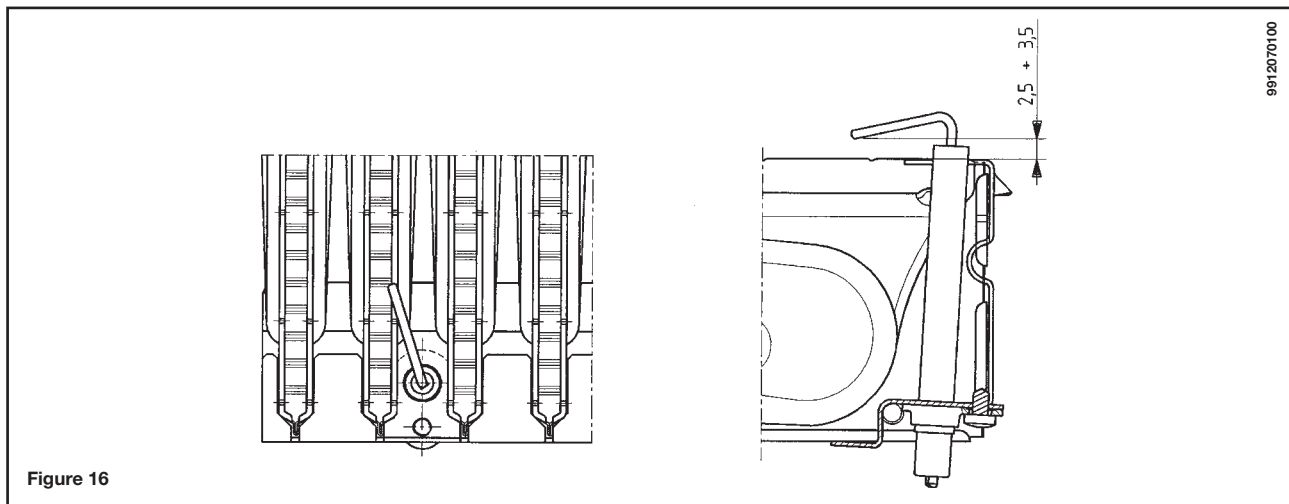

## 24. CHECK OF COMBUSTION PARAMETERS

The boiler has two connection points specifically designed to allow technicians to measure the combustion efficiency after installation and ensure that the combustion products do not constitute a health risk.

One connection point is connected to the flue gas discharge circuit, and allows monitoring of the quality of the combustion products and the combustion efficiency.

The other is connected to the combustion air intake circuit, allowing checking of any recycling of the combustion products in case of coaxial pipelines.

The following parameters can be measured at the connection point on the flue gas circuit:

- temperature of the combustion products;
- oxygen (O<sub>2</sub>) or carbon dioxide (CO<sub>2</sub>) concentration;
- carbon monoxide (CO) concentration.

The combustion air temperature must be measured at the connection point on the air intake circuit, inserting the measurement probe to a depth of about 3 cm.

The boiler has two connection points specifically designed to allow technicians to measure the combustion efficiency after installation and ensure that the combustion products do not constitute a health risk.

One connection point is connected to the flue gas discharge circuit, and allows monitoring of the quality of the combustion products and the combustion efficiency.

The other is connected to the combustion air intake circuit, allowing checking of any recycling of the combustion products in case of coaxial pipelines.

The following parameters can be measured at the connection point on the flue gas circuit:

- temperature of the combustion products;
- oxygen (O<sub>2</sub>) or carbon dioxide (CO<sub>2</sub>) concentration;
- carbon monoxide (CO) concentration.

The combustion air temperature must be measured at the connection point on the air intake circuit, inserting the measurement probe to a depth of about 3 cm.

For natural draught boiler models, a hole must be made in the flue gas discharge pipe at a distance from the boiler equal to twice the inside diameter of the pipe itself.

The following parameters can be measured through this hole:

- temperature of the combustion products;
- oxygen (O<sub>2</sub>) or carbon dioxide (CO<sub>2</sub>) concentration;
- carbon monoxide (CO) concentration.

The combustion air temperature must be measured close to the point where the air enters the boiler.

The hole, which must be made by the person in charge of operating the system when it is commissioned, must be sealed in a way which ensures that the combustion product discharge pipe is airtight during normal operation.

## 25. OUTPUT / PUMP HEAD PERFORMANCES

This is a high static head pump fit for installation on any type of single or double-pipe heating systems. The air vent valve incorporated in the pump allows quick venting of the heating system.

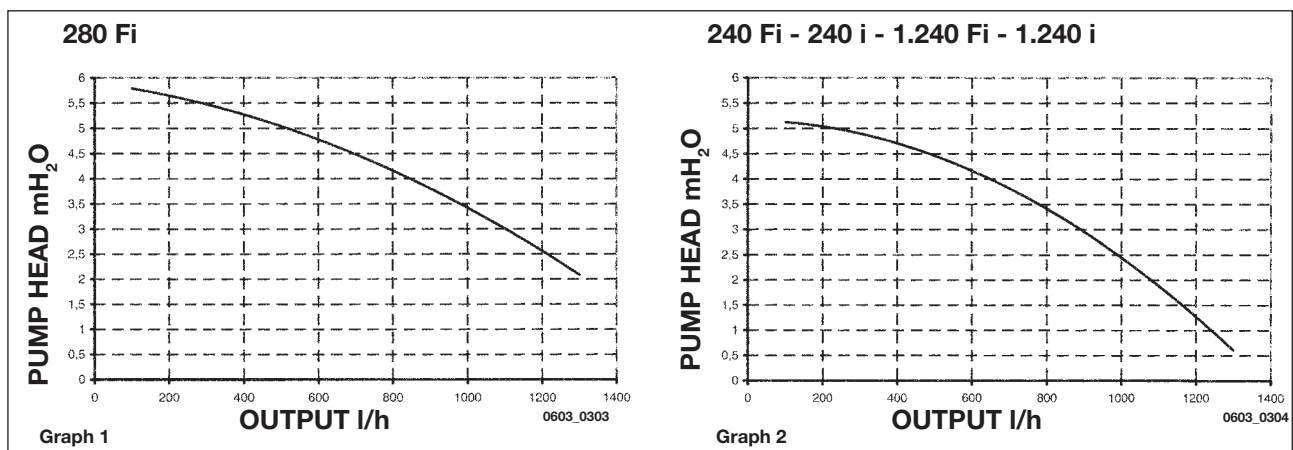

## 26. CONNECTION OF THE EXTERNAL PROBE

The boiler is prearranged for connection of an external probe (supplied as accessory).

For the connection, refer to the figure 17 and the instructions supplied with the probe.

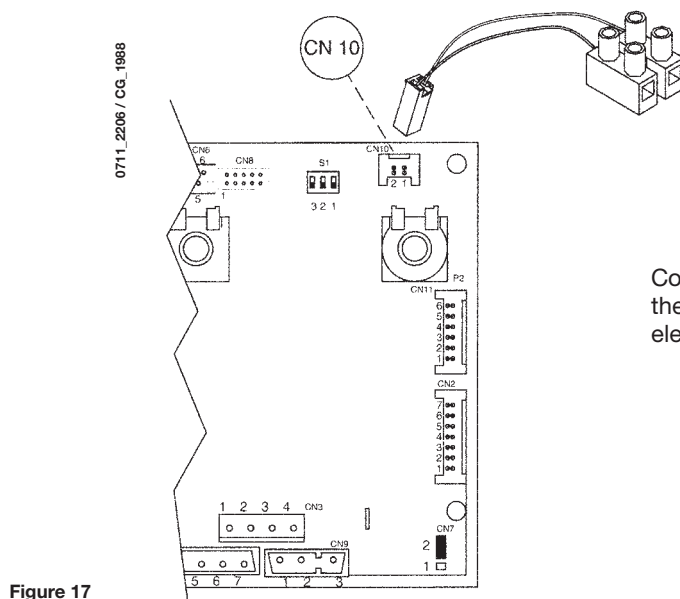

Connect the cable, supplied as an accessory together with the external probe, to the **CN10** connector of the boiler electronic board, as illustrated in figure 17.

When the external probe is connected, the heating circuit temperature control device (2 - figure 1), regulates the dispersal coefficient Kt (Figure 18).

The figures below show the relation between knob position and curves. Intermediate curves may also be set.

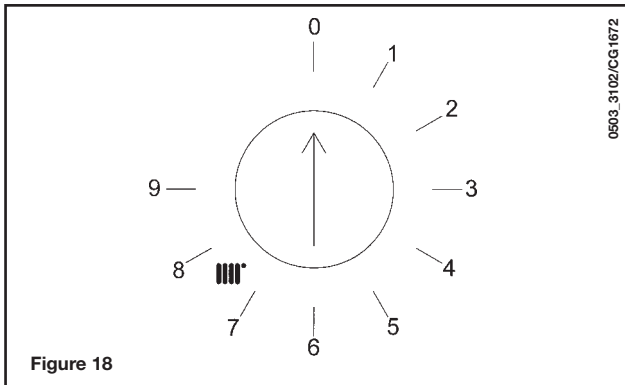
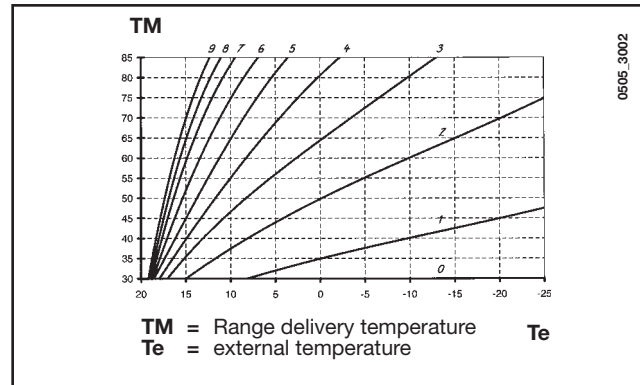

Figure 18



**IMPORTANT:** the **TM** delivery temperature value depends on the position of the jumper or the switch T.RISC. (section 23). The maximum possible temperature setting is 85 or 45°C.

## 27. CONNECTING AN EXTERNAL BOILER

**For models 1.240 Fi - 1.240 i**

**IMPORTANT:** jumper CN7 must be jumpered (see paragraph 32).

Connect the boiler water pipes as shown in figure 19.

Remove the resistor from terminal board and connect the optional DHW priority sensor to them.

Insert the sensor's probe in the relevant hole in the boiler.

Set domestic hot water temperature (5°...60 °C) using the control knob (1 - figure 1).

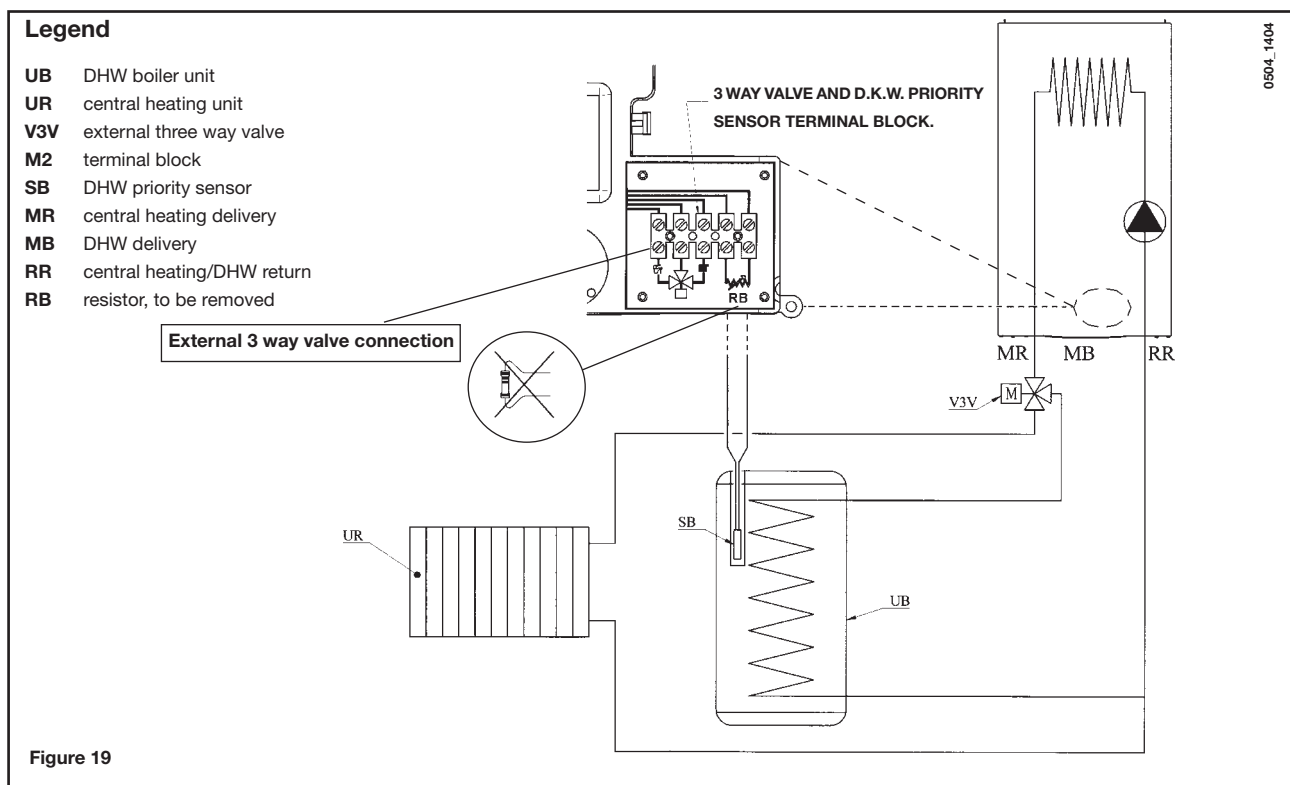

Figure 19

## 28. HOW TO PURGE THE DHW SYSTEM FROM LIMESTONE DEPOSITS

To clean the DHW system it is not necessary to remove the DHW heat exchanger if the assembly is equipped with the appropriate taps (supplied on demand) placed on the hot water outlet and inlet.

To carry out the purge it is necessary to:

- close the cold water inlet
- drain the DHW system from the water contained therein by means of a hot water tap
- close the DHW outlet
- unscrew the two stop cocks caps
- remove the filters.

In case the appropriate tap is not supplied it is necessary to disassemble the DHW heat exchanger, as described in the following section, and do the purge aside. We recommend you also purge from limestone deposits the DHW heat exchanger seat and the NTC sensor fitted on the DHW system.

To purge the exchanger and/or the DHW system we suggest the use of Cillit FFW-AL or Beckinser HF-AL.

## 29. HOW TO DISASSEMBLE THE DHW HEAT EXCHANGER

The stainless steel plate-type DHW heat exchanger is easily disassembled with a screwdriver by operating as described below:

- drain, if possible, only the boiler system, **through the drain tap**;
- drain the DHW system from water;
- remove the two screws (right in front of you) securing the DHW heat exchanger and pull it off its seat (figure 19).

## 30. CLEANING THE COLD WATER FILTER

The boiler is equipped with a cold water filter placed on the hydraulic assembly.

To clean it do the following:

- drain the DHW system from water;
- unscrew the nut on the flow sensing assembly (Figure 19);
- pull out the flow sensing device and its filter;
- remove the impurities.

**Important:** in the event of replacements and/or cleaning of the O-rings on the hydraulic unit, do not use oil or grease as lubricant but exclusively Molykote 111.

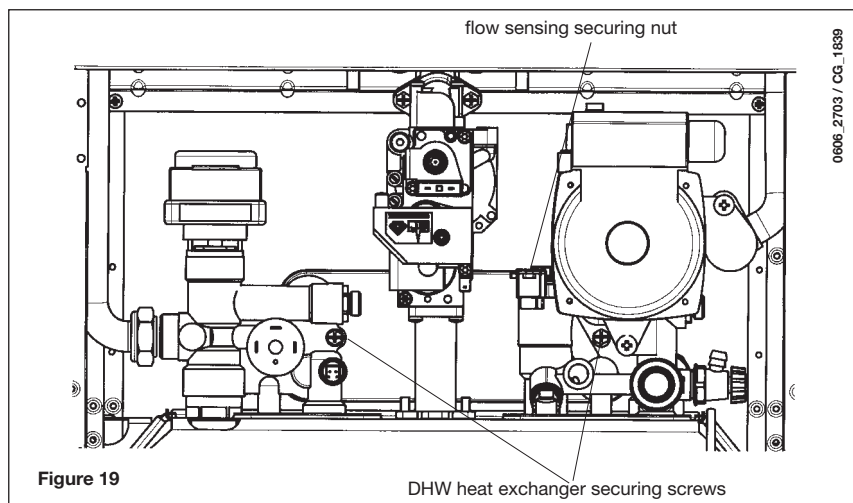

Figure 19

DHW heat exchanger securing screws

# 31. BOILER SCHEMATIC

240 Fi - 280 Fi

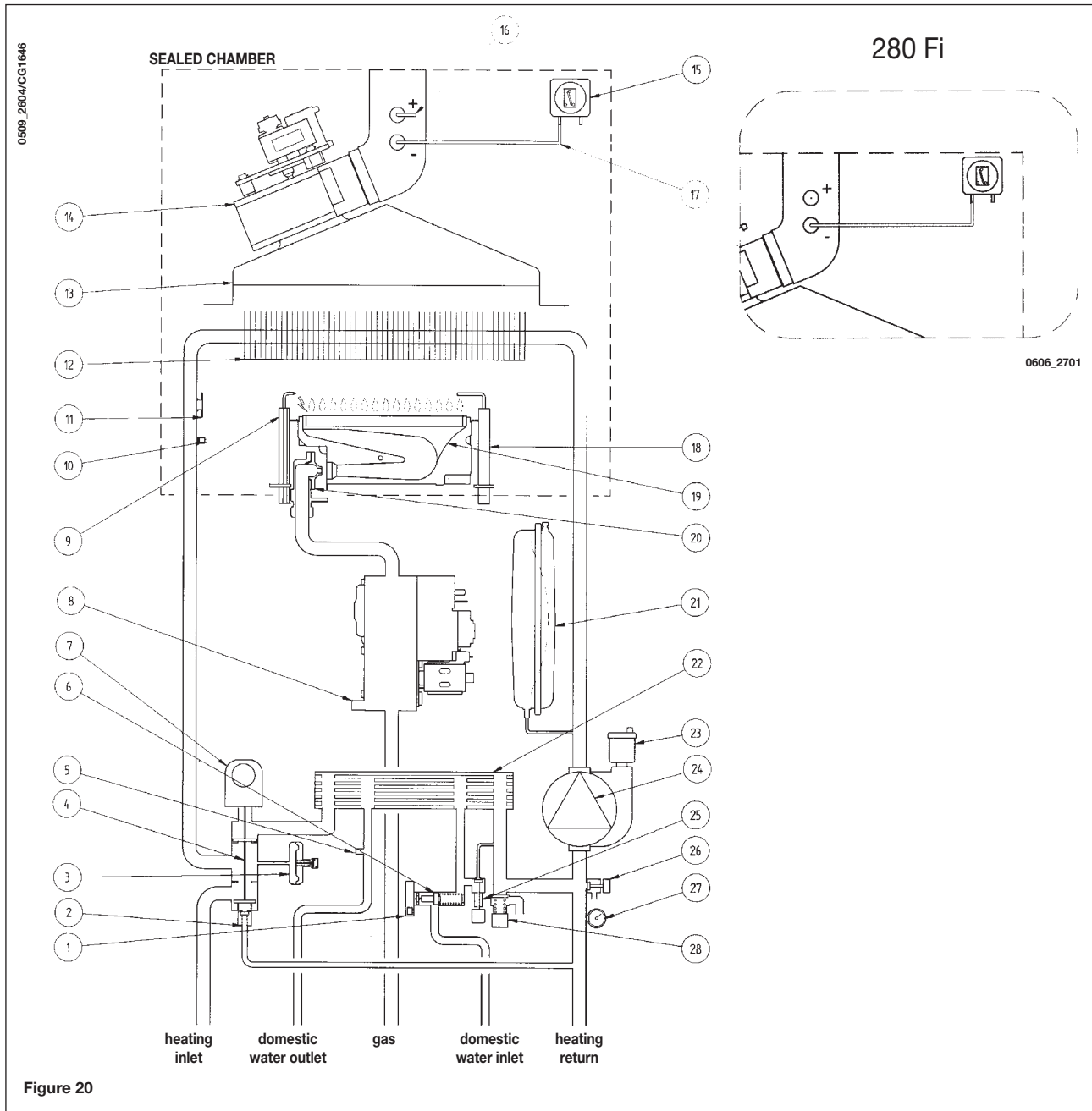
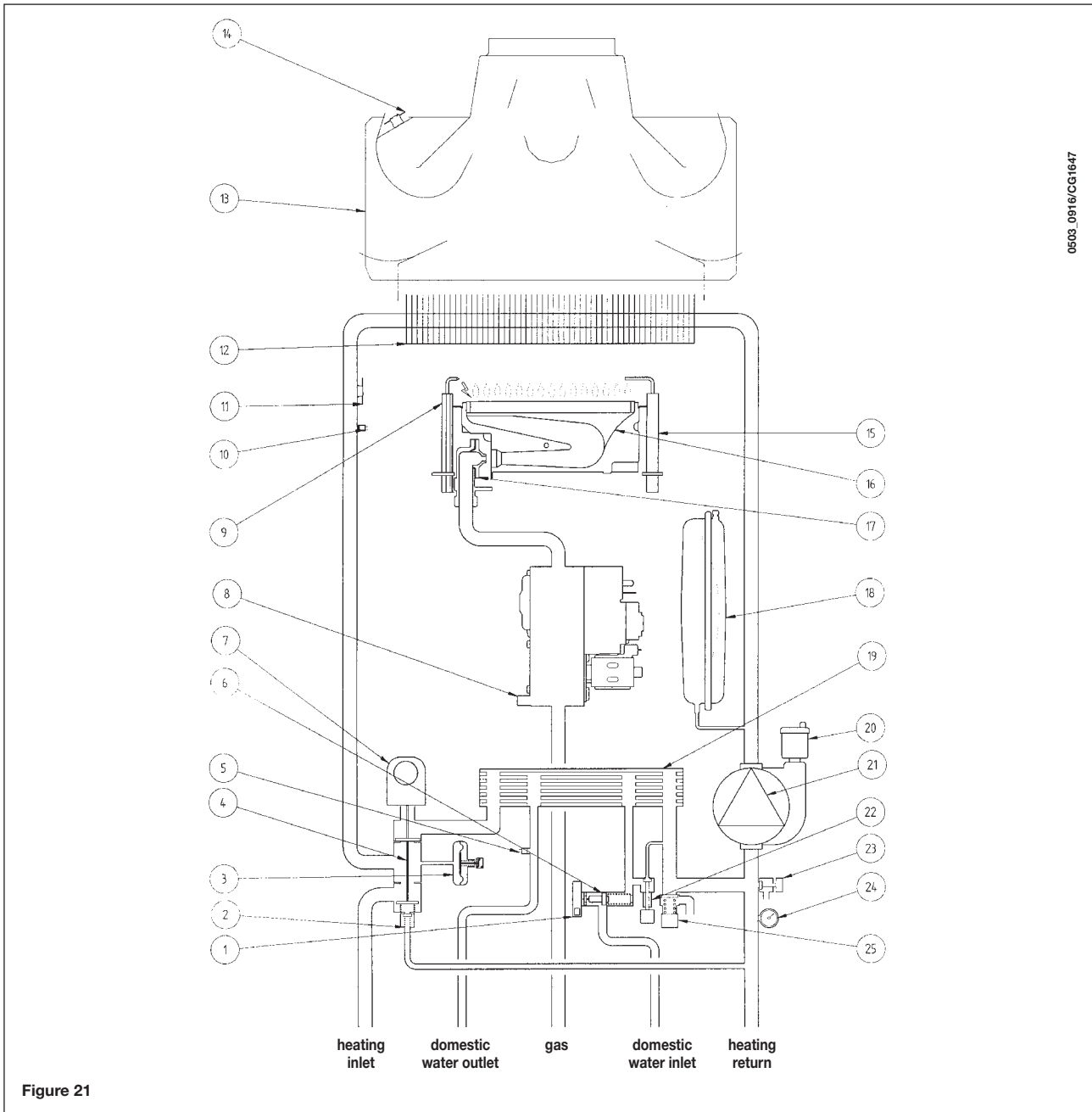

Figure 20

## Key:

- |   |                                  |
|---|----------------------------------|
| 1 DHW priority sensor                                 | 15 air pressure switch           |
| 2 automatic by-pass                                   | 16 positive pressure point       |
| 3 water pressure switch                               | 17 negative pressure point       |
| 4 three way valve                                     | 18 flame detector electrode      |
| 5 DHW NTC sensor                                      | 19 main burner                   |
| 6 flow sensor with filter and water flow rate limiter | 20 burner injectors              |
| 7 3-way valve motor                                   | 21 expansion vessel              |
| 8 gas valve   | 22 plate heat exchanger (D.H.W.) |
| 9 ignition electrode                                  | 23 automatic air vent            |
| 10 central heating NTC sensor                         | 24 pump and air separator        |
| 11 overheat safety thermostat                         | 25 filling the system            |
| 12 flue-water exchanger                               | 26 boiler drain point            |
| 13 flue hood  | 27 manometer                     |
| 14 fan  | 28 pressure relief valve         |





0503\_0916/CG1647

**Key:**

- |   |                                  |
|---|----------------------------------|
| 1 DHW priority sensor                                 | 14 flue thermostat               |
| 2 automatic by-pass                                   | 15 flame detector electrode      |
| 3 water pressure switch                               | 16 main burner                   |
| 4 three way valve                                     | 17 burner injectors              |
| 5 DHW NTC sensor                                      | 18 expansion vessel              |
| 6 flow sensor with filter and water flow rate limiter | 19 plate heat exchanger (D.H.W.) |
| 7 3-way valve motor                                   | 20 automatic air vent            |
| 8 gas valve   | 21 pump and air separator        |
| 9 ignition electrode                                  | 22 filling the system            |
| 10 central heating NTC sensor                         | 23 boiler drain point            |
| 11 overheat safety thermostat                         | 24 manometer                     |
| 12 flue-water exchanger                               | 25 pressure relief valve         |
| 13 flue hood  |                                  |

## 1.240 Fi

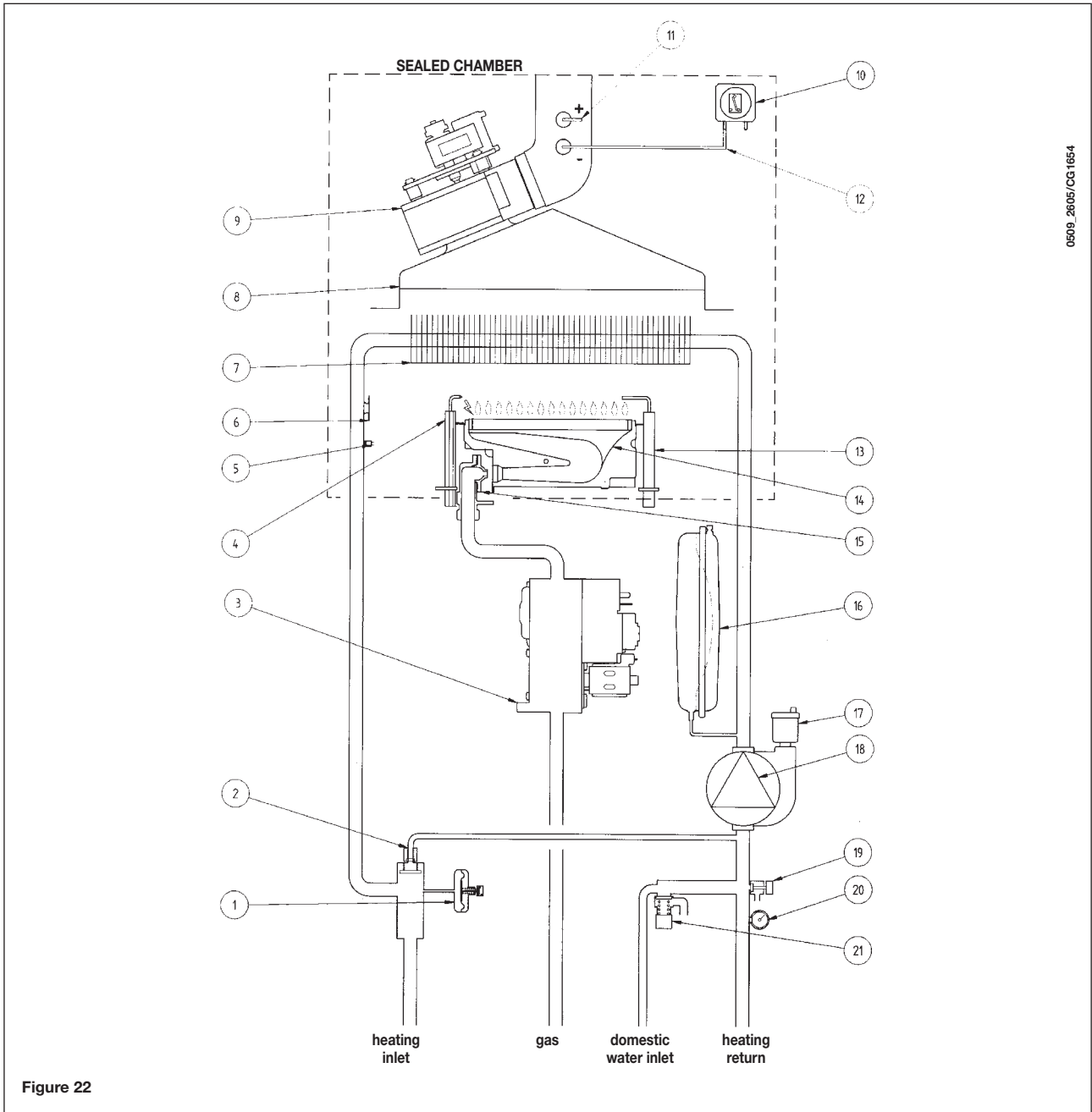
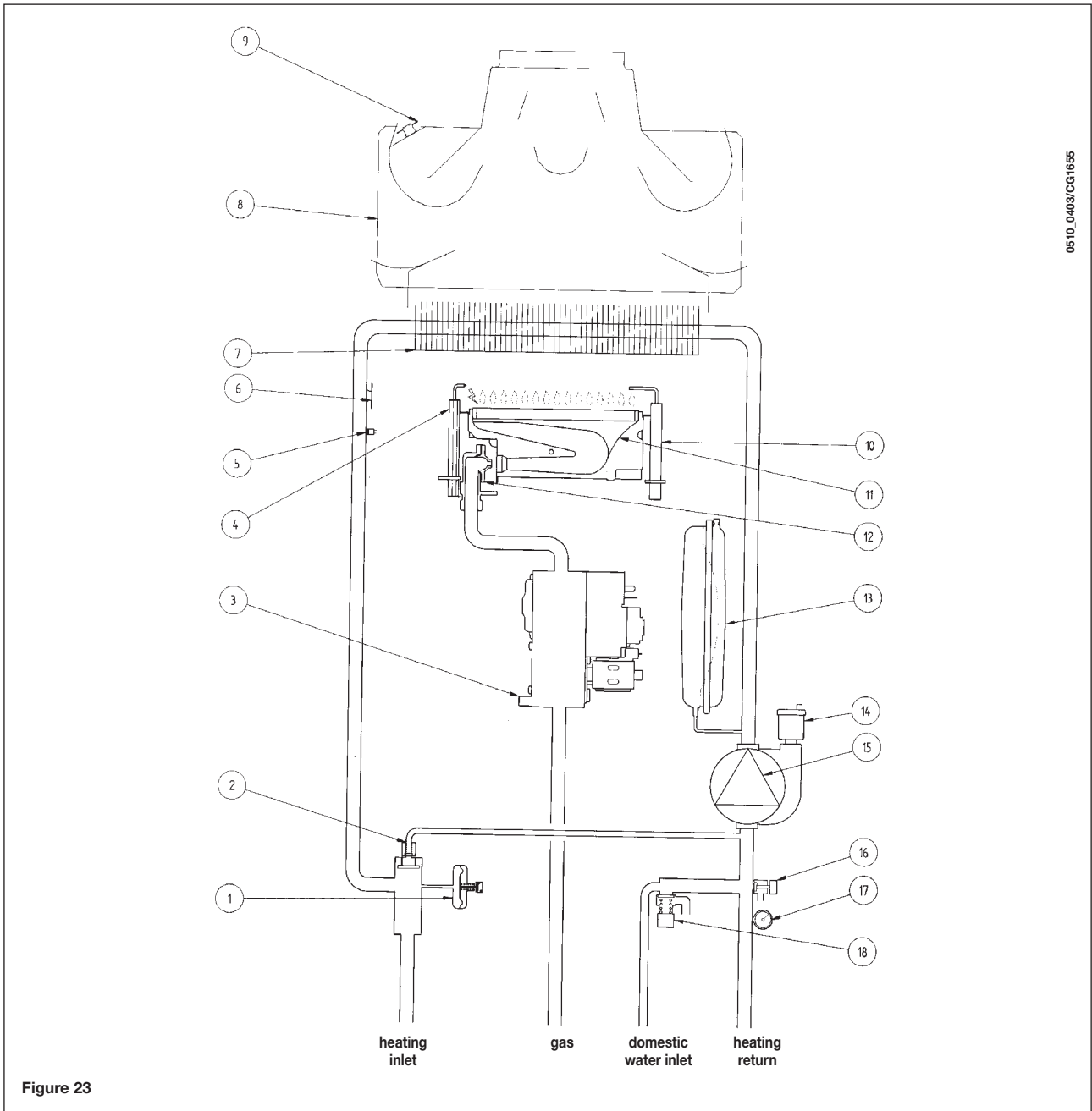

Figure 22

**Key:**

- |   |  |
|---|--|
| <ul style="list-style-type: none"> <li>1 water pressure switch</li> <li>2 automatic bypass</li> <li>3 gas valve</li> <li>4 ignition electrode</li> <li>5 central heating NTC sensor</li> <li>6 overheat safety thermostat</li> <li>7 flue-water exchanger</li> <li>8 flue hood</li> <li>9 fan</li> <li>10 air pressure switch</li> <li>11 positive pressure point<br/>(Not featured on 1.140 Fi)</li> </ul> | <ul style="list-style-type: none"> <li>12 negative pressure point</li> <li>13 flame detector electrode</li> <li>14 main burner</li> <li>15 burner injectors</li> <li>16 expansion vessel</li> <li>17 automatic air vent</li> <li>18 pump and air separator</li> <li>19 boiler drain point</li> <li>20 manometer</li> <li>21 pressure relief valve</li> </ul> |
|---|--|

## 1.240 i



**Key:**

- |  |  |
|--|--|
| <ul style="list-style-type: none"> <li>1 water pressure switch</li> <li>2 automatic bypass</li> <li>3 gas valve</li> <li>4 ignition electrode</li> <li>5 central heating NTC sensor</li> <li>6 overheat safety thermostat</li> <li>7 flue-water exchanger</li> <li>8 flue hood</li> <li>9 flue thermostat</li> </ul> | <ul style="list-style-type: none"> <li>10 flame detector electrode</li> <li>11 main burner</li> <li>12 burner injectors</li> <li>13 expansion vessel</li> <li>14 automatic air vent</li> <li>15 pump and air separator</li> <li>16 boiler drain point</li> <li>17 manometer</li> <li>18 pressure relief valve</li> </ul> |
|--|--|

# 32. ILLUSTRATED WIRING DIAGRAM

240 Fi - 280 Fi

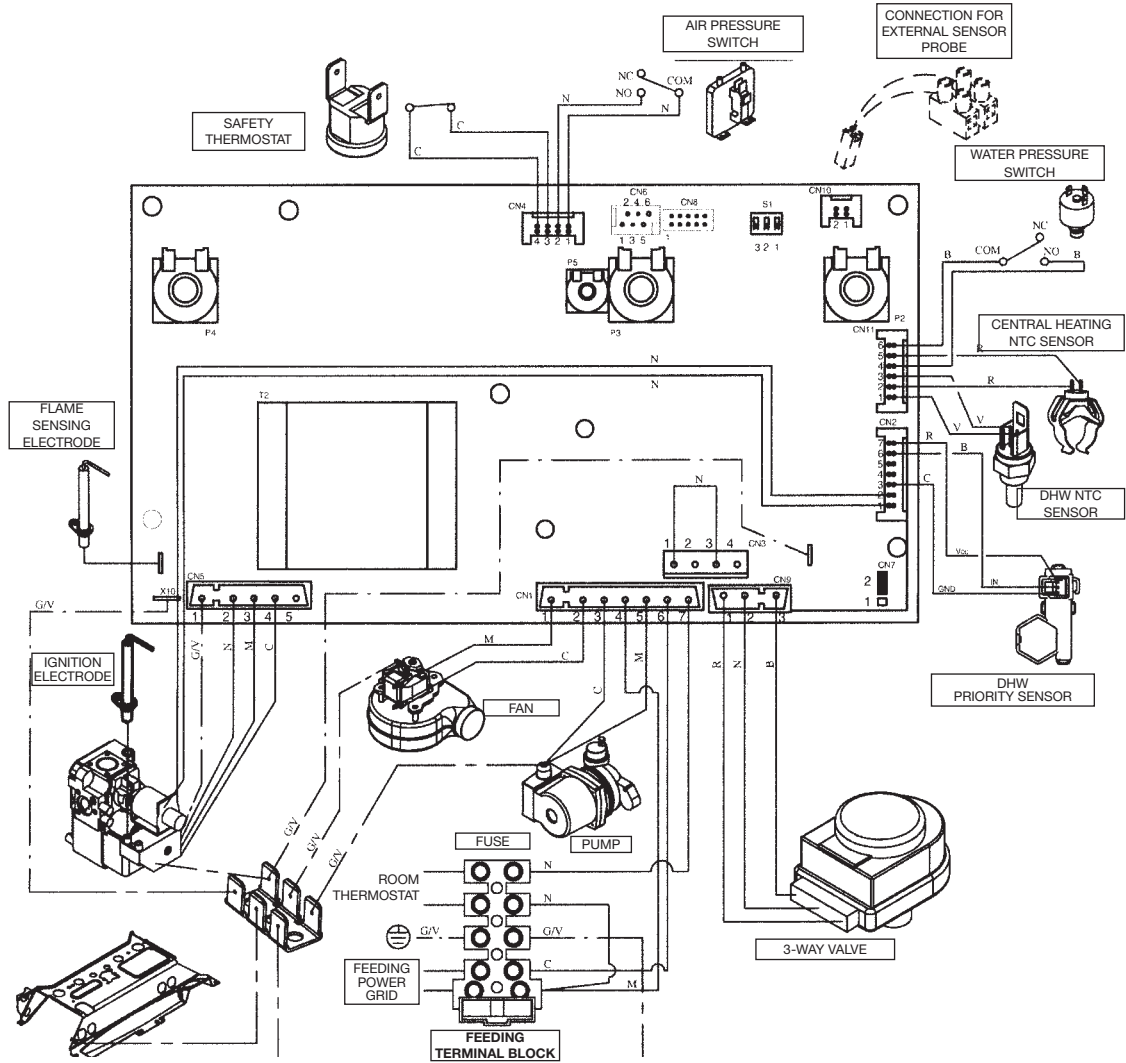

0711\_2211 / CG\_1801\_1

## CABLES COLOURS

- C=** light blue
- M=** brown
- N=** black
- R=** red
- G/V=** yellow/green
- B=** white
- V=** green

## KEY

- P2:** DHW potentiometer
- P3:** S/W/OFF selector
- P4:** Central heating potentiometer
- P5:** Heating power regulation trimmer

# 240 i

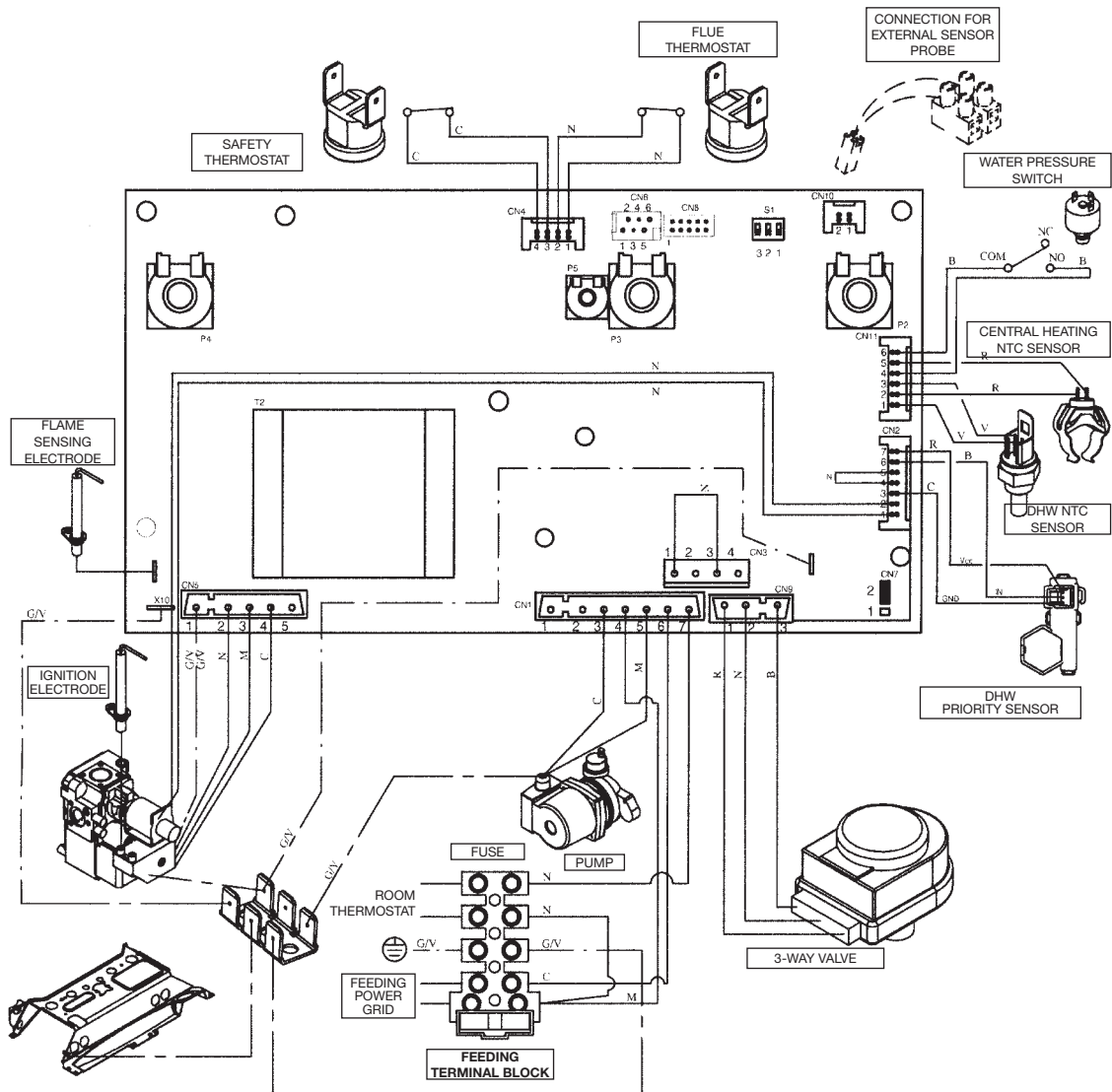

0803\_1006 / CC\_1802\_2

## CABLES COLOURS

**C=** light blue  
**M=** brown  
**N=** black  
**R=** red  
**G/V=** yellow/green  
**B=** white  
**V=** green

## KEY

**P2:** DHW potentiometer  
**P3:** S/W/OFF selector  
**P4:** Central heating potentiometer  
**P5:** Heating power regulation trimmer

## 1.240 Fi

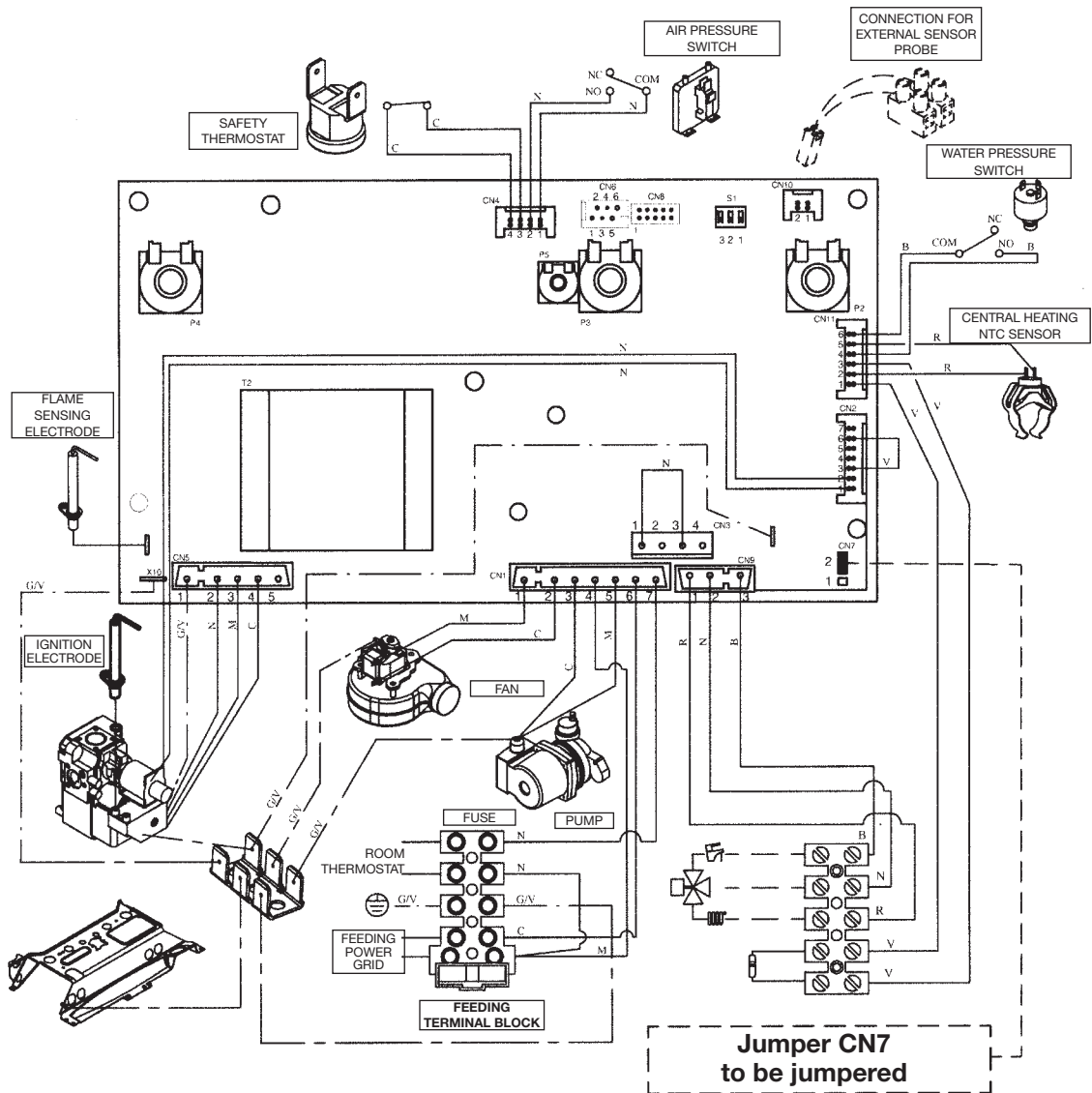

0711\_2213 / CG\_1981

### CABLES COLOURS

- C=** light blue
- M=** brown
- N=** black
- R=** red
- G/V=** yellow/green
- B=** white
- V=** green

### KEY

- P2:** DHW potentiometer
- P3:** S/W/OFF selector
- P4:** Central heating potentiometer
- P5:** Heating power regulation trimmer
- RB:** Resistor, to be removed if an external boiler is connected

# 1.240 i

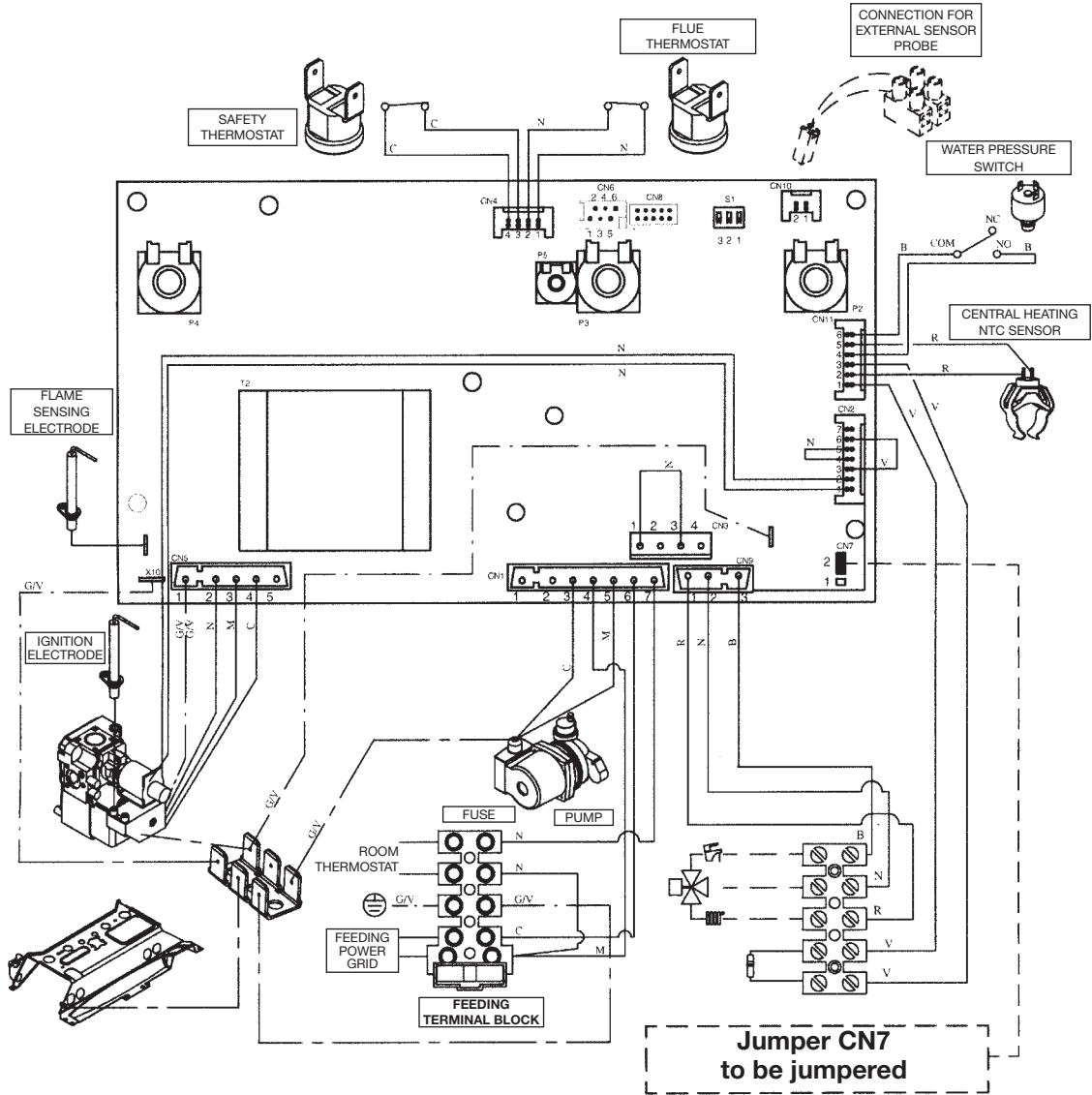

0711\_2214 / CG\_1982

## CABLES COLOURS

- C=** light blue
- M=** brown
- N=** black
- R=** red
- G/V=** yellow/green
- B=** white
- V=** green

## KEY

- P2:** DHW potentiometer
- P3:** S/W/OFF selector
- P4:** Central heating potentiometer
- P5:** Heating power regulation trimmer
- RB:** Resistor, to be removed if an external boiler is connected



## 33. TECHNICAL DATA

<b>Model ECO3</b>		<b>240 Fi</b>	<b>1.240 Fi</b>	<b>280 Fi</b>	<b>240 i</b>	<b>1.240 i</b>
<b>Category</b>		<b>II<sub>2H3P</sub></b>	<b>II<sub>2H3P</sub></b>	<b>II<sub>2H3P</sub></b>	<b>II<sub>2H3P</sub></b>	<b>II<sub>2H3P</sub></b>
Maximum heat input	kW	25,8	25,8	30,1	26,3	26,3
Reduced heat input	kW	10,6	10,6	11,9	10,6	10,6
Maximum heat output	kW	24	24	28	24	24
	kcal/h	20.600	20.600	24.080	20.600	20.600
Reduced heat output	kW	9,3	9,3	10,4	9,3	9,3
	kcal/h	8.000	8.000	8.900	8.000	8.000
Useful efficiency according to 92/42/CEE directive	—	★★★	★★★	★★★	★★	★★
Central heating system max. pressure	bar	3	3	3	3	3
Expansion vessel capacity	l	8	8	10	8	8
Expansion vessel pressure	bar	0,5	0,5	0,5	0,5	0,5
DHW system max. pressure	bar	8	-	8	8	-
DHW system min. dynamic pressure	bar	0,5	-	0,5	0,5	-
DHW system min. output	l/min	2	-	2	2	-
DHW production at ΔT=25°C	l/min	13,7	-	16	13,7	-
DHW production at ΔT=35°C	l/min	9,8	-	11,4	9,8	-
Specific output (*)	l/min	10,7	-	12,5	10,7	-
Type	—	C12-C32-C42-C52-C82-B22			B <sub>11BS</sub>	B <sub>11BS</sub>
Concentric flue duct diameter	mm	60	60	60	-	-
Concentric air duct diameter	mm	100	100	100	-	-
2-pipe flue duct diameter	mm	80	80	80	-	-
2-pipe air duct diameter	mm	80	80	80	-	-
Discharge pipe diameter	mm	-	-	-	120	120
Max. flue mass flow rate	kg/s	0,016	0,016	0,017	0,021	0,019
Min. flue mass flow rate	kg/s	0,015	0,015	0,017	0,018	0,017
Max. flue temperature	°C	135	135	140	110	110
Min. flue temperature	°C	100	100	110	85	85
NOx Classe	—	3	3	3	3	3
Type of gas used	—	G20	G20	G20	G20	G20
	—	G31	G31	G31	G31	G31
Natural gas feeding pressure	mbar	20	20	20	20	20
Propane gas feeding pressure	mbar	37	37	37	37	37
Power supply voltage	V	230	230	230	230	230
Power supply frequency	Hz	50	50	50	50	50
Power consumption	W	135	135	165	80	80
Net weight	kg	38	32	40	33	28
Dimensions	height	mm	763	763	763	763
	width	mm	450	450	450	450
	depth	mm	345	345	345	345
Protection-limit against humidity and water leakages (**)		IP X5D	IP X5D	IP X5D	IP X5D	IP X5D

(\*) according to EN 625

(\*\*) according to EN 60529



# **BAXI S.p.A.**

36061 BASSANO DEL GRAPPA (VI) ITALIA  
Via Trozzetti, 20  
Tel. 0424 - 517111  
Telefax 0424/38089