



INSTRUCTION FOR USE



**FLOOR STANDING
CAST-IRON
SOLID FUEL
BURNING BOILER**

ATTACK FD

Dear customer,

***Thank you for buying a universal ATTACK FD boiler and trust expressed to our company --
ATTACK, s.r.o.***

ATTACK FD boiler is certified for burning coke, wood and black coal.

***To get used to right handling with your new product, read instructions for its use. Please follow
the further information to ensure long-time operation without breakdowns to your as well as our
satisfaction.***

Important warnings

- Study the instructions to get essential information about the construction of the boiler, it's manipulation and it's safe operation
- After unpacking the boiler check whether your delivery is complete
- Make sure that the type of the boiler corresponds to the required use
- The installation must be done only by a professional with permission to this operation
- Launching and putting the boiler into operation and other obligatory service inspections may be done only by a service technician with a valid contract from the producer
- The boiler must be connected according to valid rules, standards and norms from the instructions of use
- The producer is not responsible for the damages caused by incorrect connection
- In case of a failure ask a service technician for a help, any unprofessional intervention may damage the boiler!
- For the right function, safety and long time operation of the boiler get a regular check and maintenance from one of our service organizations at least once a year
- You must only use the original spare parts for the repairs
- If the boiler is out of order for a longer time (switched off or there is a breakdown), it is necessary to be careful when putting the boiler back to operation
- **The producer reserves the right to make changes in the construction of the boiler and in the instructions of use**

CONTENTS

1	Use and preferences of the boiler.....	4
2	Technical data on ATTACK FD boiler.....	4
3	Dimensions of ATTACK FDboiler.....	5
4	Head losses.....	5
5	Description of ATTACK FD.....	6
6	Localization and installation of the boiler.....	6-7
7	Supply and wrapping.....	8
8	Appliance for excessive heat removal - cooling circuit.....	8-9
9	Boiler assembly.....	10
10	Assembly of the accessories.....	10
11	Casing assembly.....	10
12	Brazier grid assembly.....	11
13	Draught regulator.....	12
14	Putting the boiler into operation.....	12
15	Attendance of the boiler by a user.....	13
16	Maintenance.....	14
17	Instructions for the liquidation of the product after its service life.....	14
18	Warranty and responsibility for defects.....	15
19	Repairs.....	15

ATTACK FD boiler is a cast iron low-pressure boiler for combustion of solid fuels - coke, wood, coal:
Combustion of other substances like plastics is not allowed..

1. The use and preferences of the boiler

Four-element size of ATTACK FD is suitable for reconstructions of heat sources in dwellings, for smaller flats and recreation facilities. Bigger size of the boiler suits to requirements for heating in family houses, shops, schools and similar..

The boiler is produced as a hot-water boiler with natural as well as forced heating water passage and working overpressure up to 4 bar. Before delivery it is tested for tightness by a testing overpressure of 8 bar.

Boiler preferences :

- *Modern design*
 - *High lifetime of cast iron heat exchanger, with extra low-temperature corrosion resistance*
 - *High efficiency up to 85%*
 - *Wide output range in dependance on number*
 - *of elements*
 - *5-years warranty on the cast iron heat exchanger*
 - *High reliability of regulating and safety components*
 - *Simple attendance and maintenance*
 - *Simple assembly of casing during the boiler assembly in the boiler room*
 - *Low demand on chimney draught*
 - *Good position of the output regulator*
 - *Enlarged combustion chamber for bigger wood pieces*
- Sophisticated production technology with a stable and verified quality of production process(ISO 9001)*

2. Technical parameters of ATTACK FD

Boiler type		FD20	FD26	FD32	FD36	FD42
Elements number	pcs	4	5	6	7	8
Nominal output - coke	kW	20	26	32	36	42
Fuel consumption at nominal output-coke	kg/h	3,7	4,8	5,9	6,66	7,77
minimum output - coke	kW	6	8	9,5	11	12,5
Fuel consumption at minimum output - coke	kg/h	1,11	1,48	1,76	2,04	2,31
Nominal output - black coal	kW (kcal/h)	18 (18000)	24 (22000)	30 (26000)	36(30000)	42(34000)
Fuel consumption at nominal output - black coal	kg/h	3,6	4,6	5,2	6,4	7,5
minimum output - black coal	kW	9	12	15	18	21
Fuel consumption at minimum output - black coal	kg/h	1,9	2,3	2,6	3,2	3,7
Nominal output - wood	kW	16	20	25	30	34
Wood consumption at nominal output	kg/h	4,85	6,11	7,38	8,65	9,92
minimum output - wood	kW	8	10	13	15	17
Wood consumption at minimum output	kg/h	2,15	2,52	2,89	3,26	4,63
Capacity of combustion chamber	dm ³	25,5	34	42,5	51	59,5
Boiler water volume	l	27	31	35	39	43
Max. working pressure	bar			4		
Weight	kg	210	245	280	315	350
Height P	mm			1081		
Height	mm			1001		
Width	mm			470		
Depth L	mm	455	555	655	755	855
Length of combustion chamber	mm	290	390	490	590	690
Width of combustion chamber	mm			300		
Dimensions of door (width x height)	mm			230 x 310		
Efficiency	%			78-82		
Test pressure	bar			8		
Connection of C.H. water	inch			G 2"		
Connection of cooling loop	inch			G1/2inner thread		
Burning time at nominal output - black coal	h			4		
Burning time at nominal output - wood	h			2		
Max.length of logs at max. diameter of 150 mm	mm	280	380	480	580	680
Operation draught at min. and nom.output	Pa	10-20	12-22	13-23	15-25	18-28
Flue gas temperature at nom. output	°C	240	250	250	260	260
Flue gas flow- nom. output	g/s	9,54	12,31	15,08	16,99	19,78
Flue gas temperature at min. output	°C	120	130	140	150	150
Flue gas flow- min. output	g/s	3,02	3,95	4,66	5,36	6,04

How to choose the right size of a boiler

The right size of a boiler, i.e. of heat output, is a very important condition for economic operation and right work of the boiler. A boiler has to be chosen in order for its nominal output to respond to losses of a heated object.

When you choose a boiler with a too high nominal output, it can cause higher tarring and dew of the boiler.

3. Dimensions of ATTACK FD

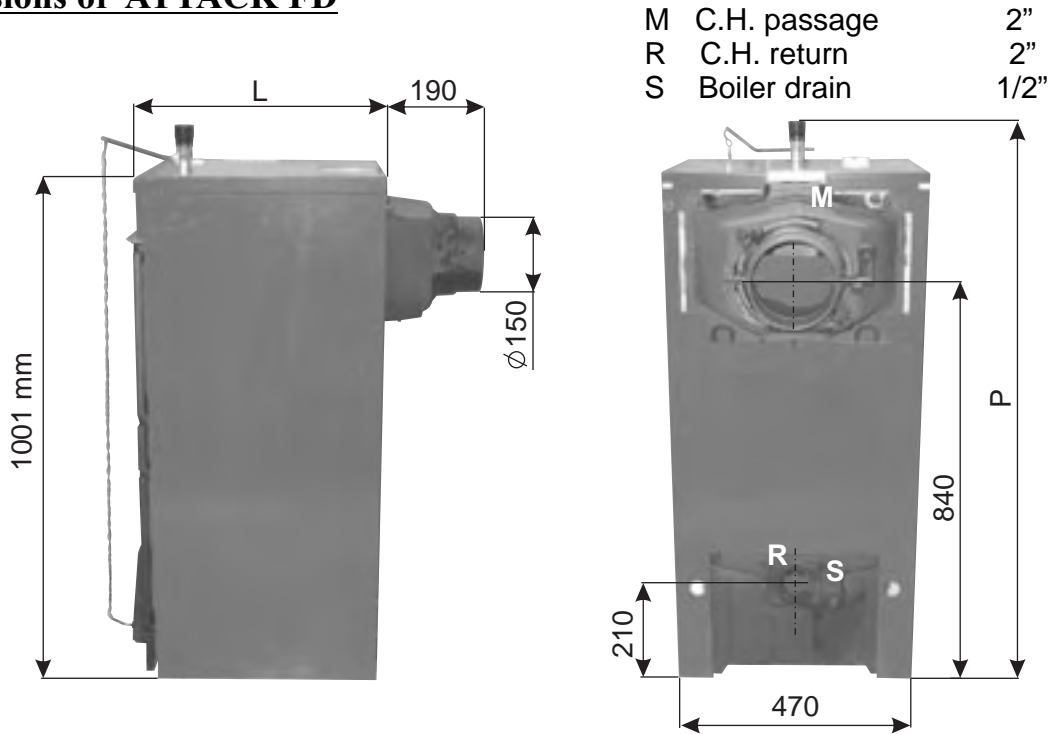

4. Head losses

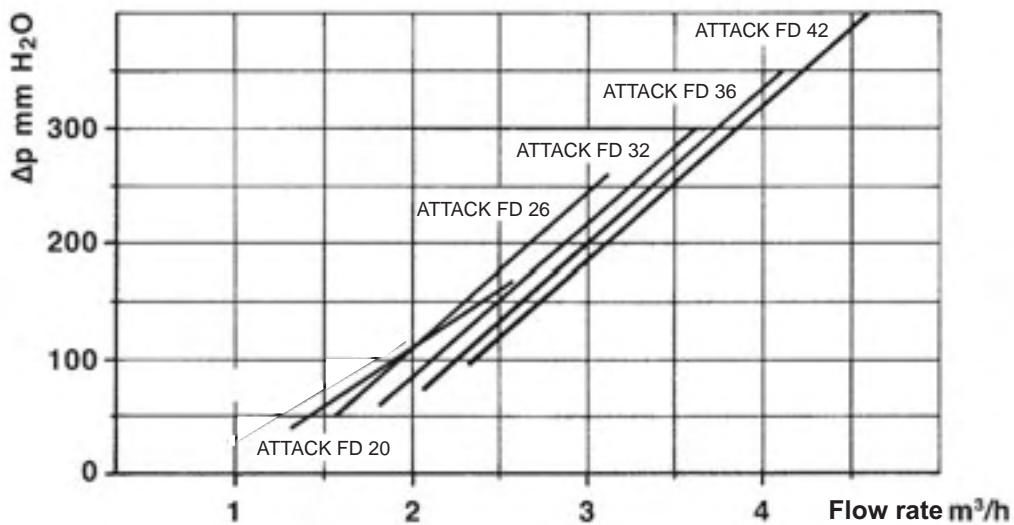

5. Description

Construction of the boiler

The main part of the boiler is a cast-iron -element boiler body produced of grey cast iron..
- middle elements - quality 150
- front and rear elements - quality 200

Pressure parts of the boiler suit to the requirements for tightness by standards:
TNN EN 303- 5 : 2000 Boilers for Central Heating.

The boiler body is assembled from elements with the help of pressed nipples of 56mm diameter, ensured by anchor bolts.. The elements create combustion and ash collection space, water space and convection part. Inlet and outlet of heating water is situated in the rear part of the boiler.

The whole boiler body is insulated by a mineral insulation not harmful for health, that eliminates losses caused by heat emission into surroundings. Steel casing is painted by a komaxit paint of a good quality.

6. Localization and installation of ATTACK FD boiler

Rules and standards

Boilers for solid fuels can be installed only by a company with a valid certificate for installation and maintenance. Installation must be designed by valid standards. Before the installation of the boiler to an older system of heating, all the system must be cleaned by the company. The heating system must be filled with water suitable to the requirements by STN 07 7401:1991 a and its hardness must not exceed required parameters.

Recommended values		
Hardness	mmol/l	1
Ca ²⁺	mmol/l	0,3
concentration of total Fe + Mn	mg/l	(0,3)*

*) recommended value

Possibilities of localization

ATTACK FD boilers is certified for installation in spaces not serving for common life (cellar, halls, etc.)

Localization of the boiler by fire regulations :

1. Localization on a floor of an incombustible material (fig.)
 - Put the boiler on an incombustible pad exceeding dimensions of the lateral sides of the boiler in 20 mm and only for the length of combustion chamber
 - If the boiler is located in a cellar, we recommend to set it up on an elevated step of the minimum height of 50 mm
 - The boiler is located into the middle of the stand

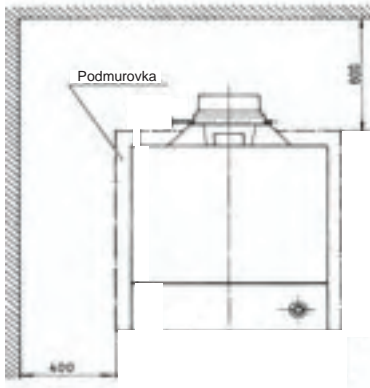

Fig. Dimensions of the elevated step.

location of the boiler to keep necessary manipulation space:

- Basic space AA5/AB5
- In front of the boiler there must be manipulation space of min. 800 mm
- minimum distance between the rear part of the boiler and the wall must be 800 mm
- at least from one lateral side keep space for approach to the rear part of the boiler - min. 800 mm

Location of fuels:

- to put fuels behind the boiler or keep them near the boiler in the distance shorter than 800 mm is not allowed
- to put fuels between two boilers in a boiler room is not allowed
- it is recommended by the manufacturer to keep the distance of min. 800 mm between the boiler and fuels, or to locate fuels in a room other than where the boiler is installed

Requirements for the boiler room

Check that the room has the requirements in accordance to the rules. Furthermore, the room should be aired in order to have a regular combustion. Therefore it is necessary to practice some openings in the walls of the room, which correspond to the following requirements:

- They should have a free section of at least 6 cm² for each 1,163 kW (1000 kcal/h). The minimum opening section shouldn't be smaller than 100 cm². The section can also be calculated using the following ratio:

$$S = \frac{Q}{100}$$

- where "S" is expressed in cm²
 - "Q" is expressed in kcal/h

-The opening should be situated in the lower part of an outer wall, preferably opposite the combustion gas discharge.

Connection to the flue

A flue should correspond to the following parameters::

- it should be of waterproof materials, resistant to temperature of smokes and condensations
- it should be of sufficient mechanical resistance and a weak thermal conductivity
- It should be hermetic in order to avoid cooling of the flue
- it should have the most possible vertical process and the terminal part should have a static aspirator, which assures an efficient and constant discharge of the combustion product
- in order to avoid the wind creating a high pressure around the chimney pot, so that it prevails on the ascensional force of the combustion gas, it is necessary that the discharge orifice hangs over at least 0,4 m of whatever structure adjacent (including the roof ridge) and the height of the chimney itself was at least 8 meters.
- The flue shouldn't have a diameter inferior to the boiler connection. For flues with square or rectangular sections, the internal section should be higher than 10% compared to the boiler connection section.
- The net section of the flue can be obtained from the following ratio:

$$S = K \frac{P}{\sqrt{H}}$$

S - section in cm²
 k - reduction coefficient - 0,045 for wood
 - 0,030 for carbon

P - boiler capacity in kcal/h

H - height of the chimney in meters measured from the flame axis at the exhaust of the chimney in the atmosphere. For the dimensioning of the flue you should consider the effective height of the chimney in meters measured from the flame axis to the top, diminished in:

- 0,50 m for each direction changing of the connection tube between boiler and flue,
- 1 m for each horizontal meter of the connection itself.

7. Supply and wrapping

Supply of the boiler consists of::

- cast iron body
- on the cast iron body there is a set ofand a bag with the documentation (instruction for use, warranty , list of service organisations, manufacturing label)
- inside the cast iron body there is an ash collector and 2 bags:
 - 1.bag contains a screw with bakelite knob for the manual adjustment of the blast gate damper, a contact spring and a M6 lever, to be fixed at the blast gate damper.
 - 2.bag contains:a thermomanometer, thermostatic draught regulator,, 2 flanges for the boiler, 2 flange packings, 8 screws with hexagonal head, 8 fan-shaped washers, return valve

Boiler casing (sidewall right and left, top cover, front panel with the logo of the manufacturer, rear cover, protective bar and 3 selftapping screws) in a cardboard box.

8. Appliance for excessive heat removal - cooling circuit (must be used in the system of closed draught)

A cooling circuit serves to excessive heat removal so that the highest water temperature in the boiler was not overreached i.e. 110°C . The cooling circuit is connected to the boiler flanges .

In case the pump stops working, discharge water is cooled by the cooling circuit, as overheating could cause opening the thermoregulating valve by 95°C . Return water is carried with the help of an interconnection between cooling circuit and the flange of return water .

To all the ATTACK FD boilers used in the system of closed ventilation it is NECESSARY to use a cooling circuit and a thermoregulation valve, in order to accept the warranty.

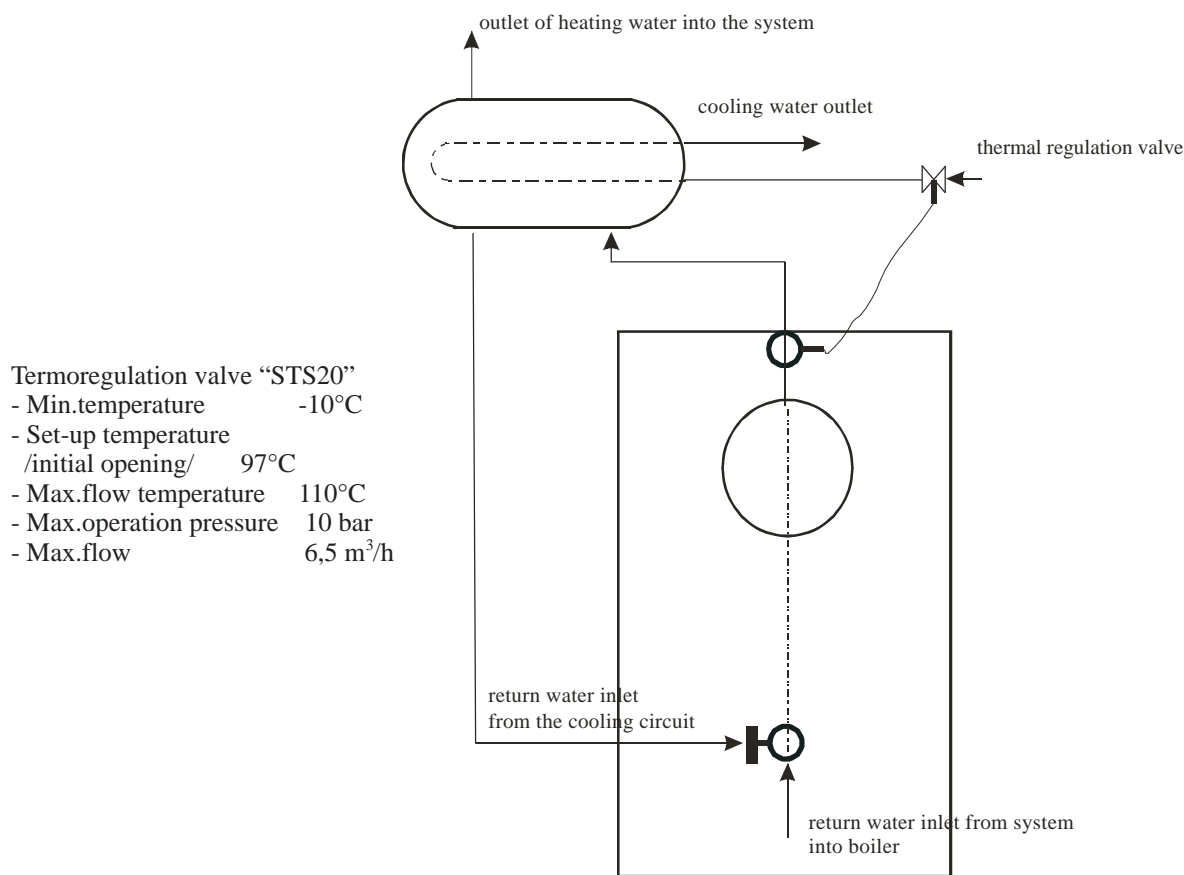

hydraulic chart of connection of cooling circuit

8a. ATTACK FD boiler used in the system of open ventilation and natural water passage

In the system of open ventilation and natural water passage it is not necessary to use a cooling circuit with a thermoregulation valve.

In case of changing the open system into the closed one it is also possible to buy a cooling circuit separately..

WARNING: Keep the rules against water pollution.

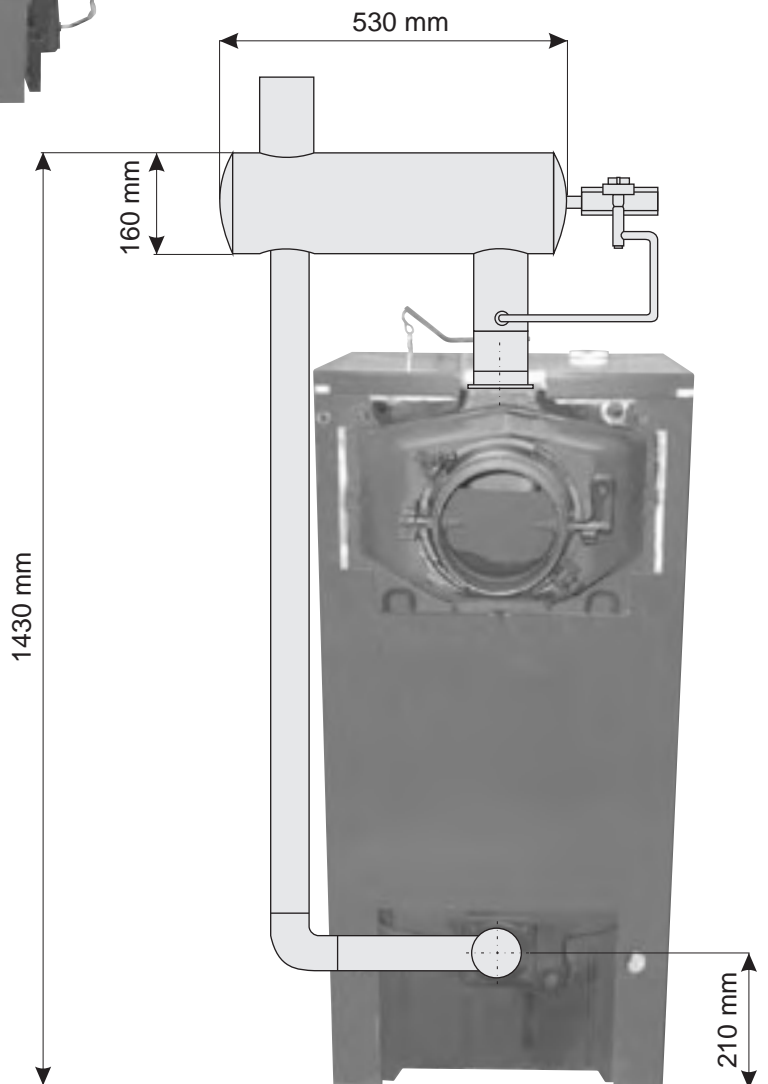
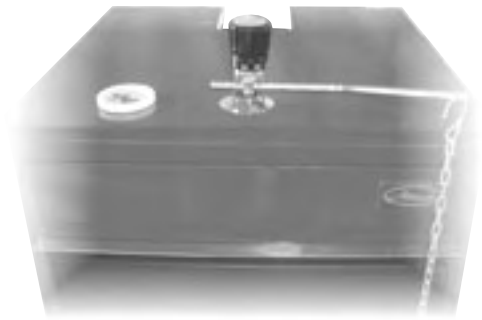
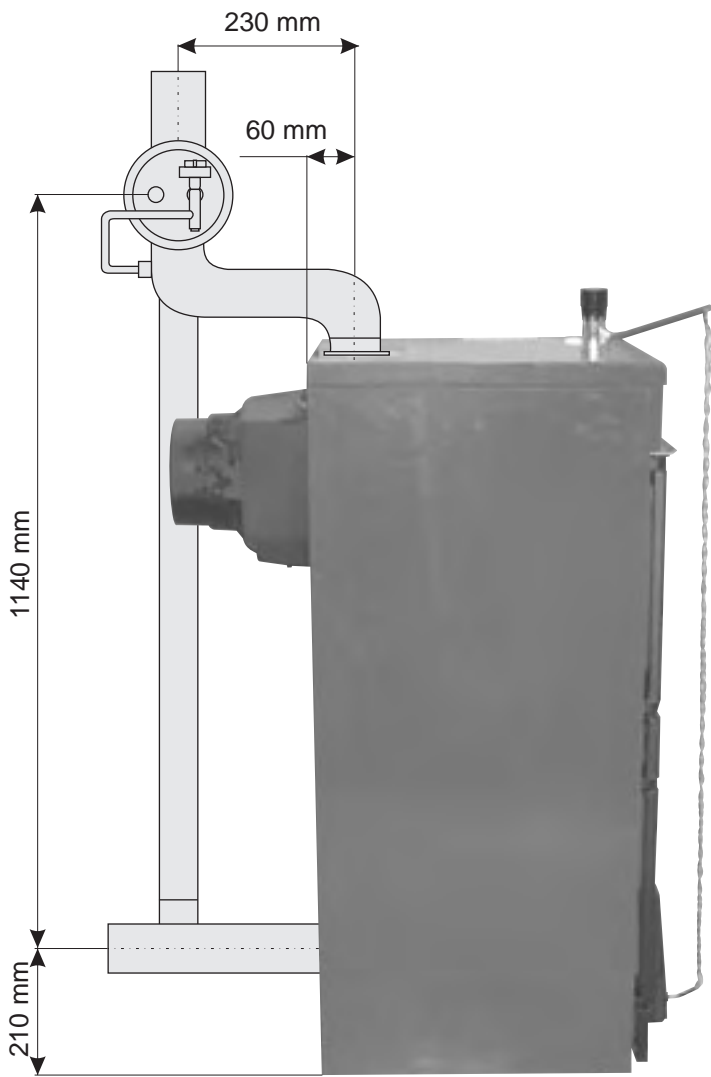

9. Boiler assembly

Set the boiler body on the place, connect heating and return water with the help of flanges with the G2" internal thread. To the outlet of heating water in the upper part of the boiler body, adjust a pipe on the G2 thread and a cooling loop on the pipe, then connect to the heating system. Into the tube. in the body of the cooling loop insert a sensor of the thermostatic valve which connect to the cooling water feed. The outlet of cooling water connect to the drainage. Connect return water from the heaters and cooling loop to the bottom part of the body.

Attach a discharge cock into the G1/2" opening in the rear bottom part of the boiler. Attach the boiler to the chimney with the help of the flue pipe with 150 mm diameter..

10. Assembly of the accessories

The closing handles for the ports and the screw with the adjustment knob for the blast gate damper are supplied separately, since they could be damaged during the transport. Both the handles and the screws with knob are packed in a nylon bag introduced inside the ash collection basin..

For the assembly of the handles proceed as following (fig.4):

- Take the handle(1), insert it into the opening of the load port(2), and introduce the roll(3) in the opening of the handle, block the handle introducing the elastic split pin(4).
- Carry out the same operation for the handle of the ash box port.

To assemble the screw with the knob, proceed as follows (fig.5):

- remove the screw M8x60 fixing the air blast damper to the ash box port and fix on the screw with the bakelite knob (1), which is supplied in the packaging. Place the blind nut with cap (2) at the end of M10 screw.
- Fix M6 lever to the air blast damper (3) placing it in a horizontal direction on the right. The lever has an opening at its end, where the chainlet of the thermostatic regulator will be connected.

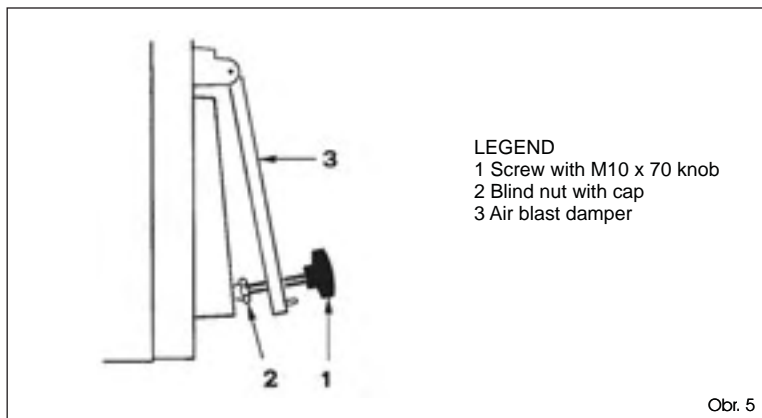
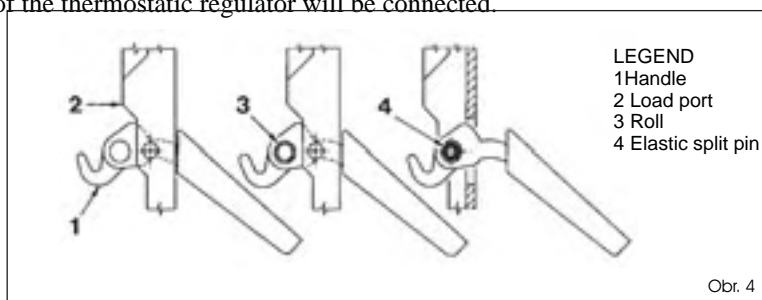

11. a) Casing assembly

Two superior tie rods are screwed on three nuts at the front side of the boiler: the second and the third nut serve to place correctly the lateral sides of the casing. Two nuts, one for fixing the clamp holders for the lateral sides, are screwed on the inferior tie rods, both from the front side and from the rear side. The assembly of the casing components has to be carried out in the following way (fig.6):

- unscrew with some rotations the second or third nut of each tie rod,
- hook the left side of the (1) on the lower tie rod and superior of the boiler and adjust the position of the nut and locknut of the upper tie rod,
- fix the lateral side in blocking the locknut,
- in order to assemble the right side (2) proceed in the same way,
- carry out the same operation to fix the back lower board (4)
- the protection deflector (5) is fixed to the control board (6) with three self-threading screws. Fix the board by means of the pressure stakes.
- insert a thermomanometer into the cover
- then unwind the capillary of the thermometer and introduce it in the left sheath of the posterior head., introducing the contact spring. To the right sheath fix a return valve and screw a manometer into the return valve
- fix the cover(7) at the lateral sides of the boiler with pins and pressure stakes..

NOTE: Keep the test certification together with the boiler documents.

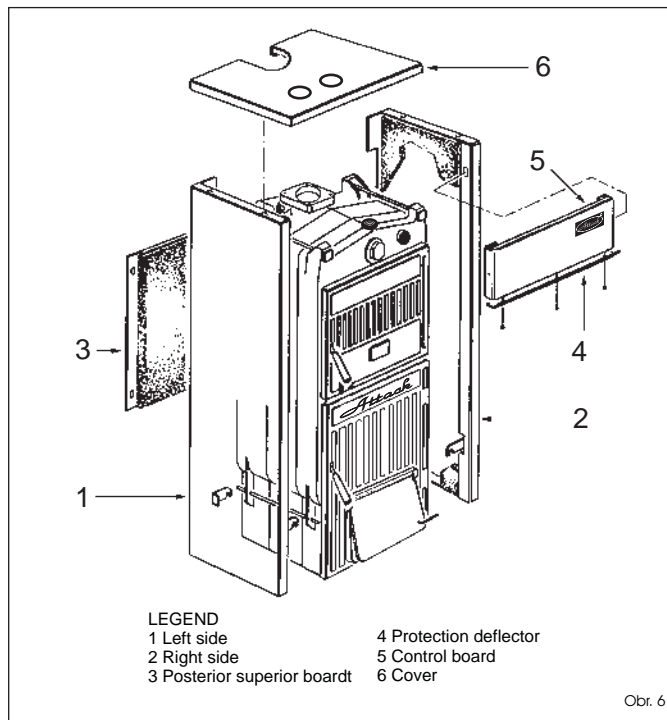

b) Assembly of the control rod of chimney flap

Assembly of the control rod of the chimney flap is done in this way::

- punch holes in the skeleton (in the right lateral side)
- insert the rod pos. 2 through the right lateral side
- at the end of the rod fix a ball pos. 3
- mount the lever pos.1 on the axis of the chimney flap.
- the rod pos. 2 insert into the lever pos. 1. Slip a washer pos.7 on the rod from both sides. After slipping lock with a pin pos. 8. On the rod put a screw, washer, and a nut pos. 4, 5 a 6. Tighten the screw slightly. Test the function of the flap. If needed, adjust the angle of slipping and tighten the screw firmly.

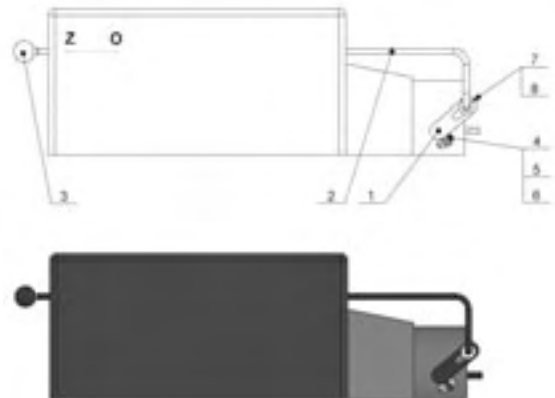

12. Brazier grid assembly

If needed (**the brazier grid is not supplied with the boiler**), the assembly is carried out by following steps (fig.3):

- Prerazi the card on the side of the front element in the bottom part, between the front and intermediate element using a bit of 10
- make a hole as in fig.3,
- place the back grid (12) in the combustion chamber,
- place the front (10) and block it to the hub (9) with the screws (8) and the nuts (7), block the front grid from the right side of the boiler body with the screws (5)
- hook the tie rod (6) to the seats extracted from the front and rear grids (11).
- introduce the ring (4) and the lever (3) on the hub (9), fixing then everything with the washer (2) and the screw (1).

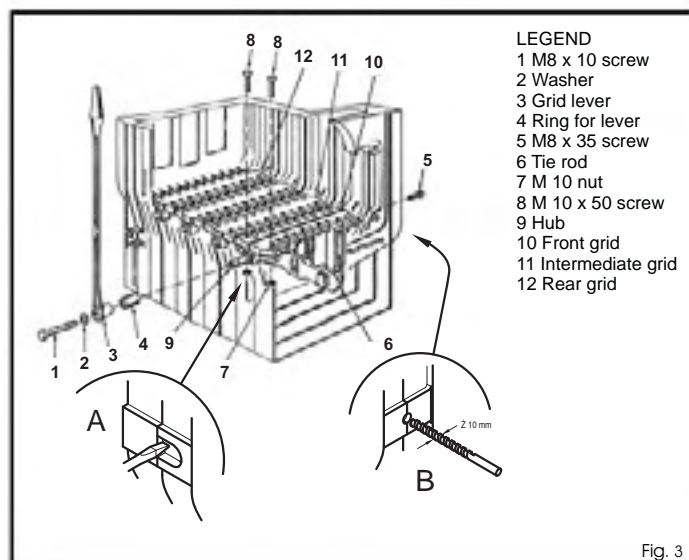

13. Draught regulator

Draught regulator - thermostatic regulator is equipped with a thermosetting resin knob of an adjustment field from 30 to 100°C (fig.7).

Screw the regulator on the 3/4" opening of the front head and orientate the red index on the upper part. The lever with the chainlet should be introduced in the regulator holder after removing the plastic lock. If the jopint which fixes the lever with the chainlet is taken out, take care in assembling it again in the same position..

After adjusting the knob to 60°C, block the lever with the chainlet in a slightly inclined position downwards, miernym smerom so that the chainlet will be in axis with the air gate damper. For the adjustment of the regulator that basicly depends on the determination of the chainlet length, proceed in the following way:

- Adjust the knob at 60°C,
- burn the boiler with open air gate damper,
- when the temperature of heating water reaches 60°C, fix the chainlet in such a position that the air gate damper will be open with the opening of cca.1mm
- Now the regulator is calibrated and it is possible to choose the desired operating temperature by a rotating head.

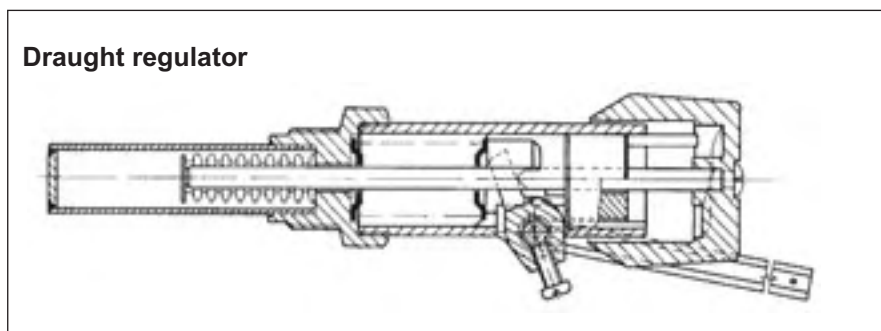

14. Putting into operation - directions for a service organisation

Putting the boiler into operation can be performed only by a service organisation certified for this activity.

Checking activities before start

Before putting the boiler into operation it is necessary to check:

- Filling the heating system with water (check by a manometer) and tightness of the set
- connection to the chimney - **this connection can only be carried out with the approval of a chimney-sweeping company, to measure the draught of the chimney by a chart of fuels**

Filling the heating system with water:

Water hardness must correspond to standards and in case of unsuitable hardness it is necessary to treat water ..

Heating systems with an open expansion tank enable a direct contact of heating water with the atmosphere. In the period of heating expanding water in the tank absorbs oxygen that increases corrosive effects and in the same time water is evaporated significantly. To refill, only water treated to values by STN 07 7401: 1992 can be used.

The heating system must be thoroughly rinsed, to wash out all the dirt..

During the heating period it is necessary to keep constant volume of water in the heating system. When refilling the heating set with water it is necessary to avoid sucking the air in the system. Water from the boiler and heating system must never be drained or taken for use except for unavoidable situations such as repairs and so on. Draining water and feeding with new one increases the danger of corrosion and incrustation. **If refilling is necessary, it can be done only to a cooled boiler to prevent breaking the elements.**

After filling the boiler and heating system check the tightness of all joints..

Finishing the assembly and testing of heating must be recorded to the Letter of warranty..

Connection to the chimney:

Connection of the boiler to the chimney must be performed by the standard and with the approval of a chimney-sweeping company. Boilers in the central heating system must be connected to a separated chimney vent. The chimney with the right draught is a basic condition for a good operation. It influences the performance of the boiler as well as its effectivity.

Putting the boiler into operation

- Start fire
 - Set the boiler to a necessary operation temperature. Recommended temperature of the outlet water is 80°C.
 - Adjust the length of the chainlet of the draught regulator (according to the instructions for the draught regulator).
 - Keep the boiler in the operation state by the proper standards.
- Again check tightness of the boiler.
- Get the customer acquainted with attendance.
 - Make a record into the Letter of Warranty..

15. Attendance of the boiler by a user

COKE

The most suitable fuel is coke of 24-60mm grain-size.

WOOD

To reach the nominal output it is necessary to keep the max. 20% moisture content of wood

Fuel must be stored in dry place..

Cleaning of the grid is made so as not to let burning fuel drop down to the ash collection basin. do popolníka

BLACK COAL

The most proper fuel is black coal of 24-60mm grain-size.

How to start fire

1. Check the amount of water in the heating system on the thermomanometer.
2. Open boiler fittings between the boiler and heating system.
3. Clean the grid, ash collection basin, flues, and walls of the boiler. (after cleaning the boiler check the tightness of the cowl)
4. Spread wood through the ash port and chamber port along all the length on the cleaned grid.
5. Flue flap in the cowl adjust into the position of open and close the load port..
6. In flame wood thorough open ash port and chamber port.
7. Close the chamber port and ash port and open the fuel cut-off slide fully.
8. On burning wood load a thin layer of basic fuel..
9. After inflaming it, load other dose of fuel up to the bottom edge of a load port and arrange the fuel into an even layer.
10. As soon as fuel gets deep red glare, open a little the air disk of secondary air inlet on the load port by means of a tool.
11. After the flame turns yellow, close the air disk of secondary air.

Operation

1. After reaching the temperature of heating water adjust the inlet of combustion air. The boiler output is regulated by the change of draught with the help the flue flap in the cowl. A slight output regulation is carried out with a fuel cut-off slide that regulates the air inlet under the grid either manually or with a draught regulator. Adjust the draught regulator so that the cut-off slide in the ash port was almost closed in the moment when the required temperature is reached.

2. Reloading the boiler during operation depends on the need for heat and burning intensity. When reloading, the layer of fuel must be equally thick.

3. When using coke, black coal, wood, it is necessary to open partially the air rose of secondary air inlet in the loading port during all the time of inflammation of reloaded fuel. (The air rose must be controlled by a tool due to the surface temperature.)

4. When starting the night operation, clean the grid, let the reloaded fuel burn thoroughly and then decrease the boiler output by cutting off the draught by the cut-off slide and turning down the air rose of the secondary air inlet. The level of opening of the cut-off slide and air rose must be tested and it is necessary to prevent escape of flue gases into the boiler room. The draught regulator should be turned off (close the cut-off slide)..

5. To restart operation of the boiler in the morning, open the cut-off slide and air rose and rake the grid after opening the ash port.

6. The ash port must be permanently closed during the operation of the boiler.

7. If necessary, deplete the ash collection basin (use protective gloves).

Dew formation and tarring of the boiler

After first burnings in a cold boiler water condenses on the walls and flows down into the ash collection space which can make the impression that the boiler is leaking. This dew disappears after setting ashes down on the inner walls of the boiler. When the boiler runs with low temperature of water under 65°C and with wet wood, water condensates in flue gases, condensate flows down cold walls of the boiler. Heating with low temperatures is also not suitable for the service life of the chimney body.

Tarring of the boiler occurs under similar conditions (low output, low temperature) furthermore during insufficient burning (lack of combustion air) Tar from the boiler can be removed best under the minimum temperature of 90°C in the boiler. This temperature can be reached fast by turning off the radiator. To prevent dew formation and tarring of the boiler, it is recommended to run the boiler with the temperature over 65°C and choose the boiler according to the needed output of the heating system.

Interrupting the operation of the boiler

The operation is interrupted when the fuel in the boiler is let to burn up. We do not recommend to haste the interruption of the operation in any way..

Shorttime interruption of the operation

For shorttime interruption of the operation clean from burnt fuel, empty the ash collection basin, clean surfaces of load port, clean the ash collection space and close the load and ash port..

Longtime interruption of the operation of the boiler

For longtime interruption of the operation (e.g. end of heating season) clean the boiler properly, so as moisture causing excessive corrosion is not kept in soot and ash..

IMPORTANT WARNING :

1. Attendance of the boiler can be only carried out by adults familiar with this instruction. To leave children without a supervision of adults near the boiler is not allowed. Any interventions endangering the health of people attending or others are not allowed.
2. If there is a danger of creating or coming of combustible vapours into the boiler room or during works when there is a temporary danger of fire or explosion (glueing of floor coverings, painting by inflammable paints), the boiler must be put out of the operation before starting the works.
3. For ignition of the boiler it is FORBIDDEN to use inflammable liquids..
4. During the operation it is FORBIDDEN to overheat the boiler..
5. No combustible objects can be put on the boiler as well as in the distance shorter than the safe one from it..
6. When taking ashes out of the boiler, there can be no combustible materials within the minimum distance of 1500 mm from the boiler..
7. When the boiler runs with the temperature lower than 65 °C, dew formation can occur on the boiler body as well as corrosion that shortens the service life of the boiler body. Therefore we recommend to run the boiler with the temperature over 65 °C.
8. After ending the heating season, it is necessary to clean the boiler, flues and a cowl thoroughly. Grease swivel pins, the chimney flap and other movable parts of the boiler with graphite grease. Keep the boiler room clean and dry.

16. Maintenance

1. Remove ashes from the ash collection basin during the operation even more times a day by the kind of the used fuel, because a full ash collection basin interferes with right distribution of combustion air under fuel and causes unequal burning of fuel on the grid. All the residuals, especially cinder, are removed before each new ignition and during restart in the boiler in the morning. Ashes need to be put into incombustible containers with covers. **During the work it is necessary to use protective aids and regard personal safety.**
2. For heating with coke, black coal and wood, clean the walls of the boiler in the grate, draughts and the cowl regularly. (with brushes - a small brush for small holes, a brush with a handle for other superficies).
3. If after the use of some fuels with more gas released tar creates on the walls of the combustion space, remove it with a scraper or by burning dry hard wood (or coke) with the boiler set on maximum operation temperature.
4. Measure the draught (by a service organization) according to the chart.

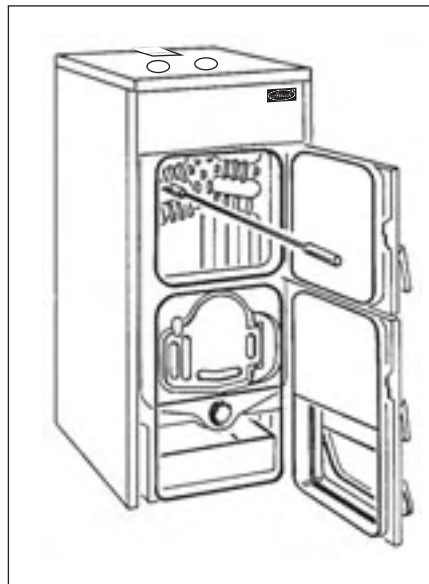

17. Directions for the liquidation of the product after its service time

As this product is made of common metal materials, we recommend to liquidate single parts in this way :

- | | |
|-----------------------------------|--|
| - heat exchanger (grey cast iron) | - through a company dealing with collection and liquidation of waste |
| - piping, casing | - through a company dealing with collection and liquidation of waste |
| - other metal parts | - through a company dealing with collection and liquidation of waste |
| - insulating material | - to common waste |

Dispose of the wrapping following these rules:

- plastic foil, cardboard wrapping and wooden palette - to common waste
- metal tape - through a company dealing with collection and liquidation of waste

18. Warranty and responsibility for defects

User is obliged to order putting into operation in a specialized company, for defects is responsible a service company certified by the manufacturer and only maintenance should be performed by the user himself..

Maintenance of the boiler must be performed regularly by the user.

Each defect must be always announced immediately after the detection in written form and its removal agreed later by phone..

If these rules are not kept, the warranty will not be accepted by the manufacturer.

The manufacturer reserves the right for changes made as the innovation of the product that are not involved in this instruction for use.

The warranty does not apply to:

- **defects caused by a wrong assembly and attendance of the product**
- **damaging the product during transportation or other mechanical damage**
- **defects caused by inappropriate storage**
- **defects caused by water of inferior quality in heating system**

More information on warranty conditions in the Letter of Warranty.

19. Repairs

A person performing the attendance of the boiler can carry out only the repairs consisting of simple exchange of parts like packing cord.

Other necessary defects can be only removed by a service company from the list that is delivered as a supplement of the instructions for use. For the repairs, use only original spare parts.

Defect	Cause	Removal
Insufficient output of the boiler	Low fuel efficiency Low pressure Heat exchanger and flue branch with flap covered by soot	Use fuel with higher efficiency for lower outside temperatures Adjust chimney Clean the elements of exchanger as well as the flue branch
Boiler cannot be regulated	Ash port is not tight Strong draught	Check and adjustment of packing cords Adjust chimney
High temperature in boiler, low one in radiators	High hydraulic resistance mainly in systems with gravity circulation Strong draught, high fuel efficiency	Decrease hydraulic resistance. by a circuit pump Decrease the draught with a flap

Producer: 

ATTACK, s.r.o.
Dielenská Kružná 5
038 61 Vrútky
SLOVAKIA

Tel: 00421 43 4003 101
Fax: 00421 43 4003 106
E-mail: kotle@attack.sk
export@attack.sk
http: www.attack.sk



Výrobca ATTACK, s.r.o. si vyhradzuje právo technických zmien výrobkov bez predchádzajúceho upozornenia.
ATTACK, s.r.o. producer reserves the right to change technical parameters and dimensions of boilers without previous warning.
Der Hersteller ATTACK, s.r.o. behält sich das Recht der technischen Veränderungen an Produkten ohne eine vorige Warnung.
Изготовитель ATTACK оставляет за собой право изменять технических параметров и размеров котла без предыдущего предупреждения.
Le producteur ATTACK Sàrl. réserve le droit des modifications techniques sans l'avertissement précédent.
Productor ATTACK, s.r.o. reserva el derecho de cambios técnicos sin advertencia anterior.