

DATA	17/09/2020
CUSTOMER	
REFERENCE	

Exchanger model		P4-14 F-F
Number of circuits		1/1
Requested capacity	kW	34,6
Margin	%	304,9
PED category		---

INPUT DATA		PRIMARY SIDE	SECONDARY SIDE
Fluid		WATER	WATER
Inlet Temperature	°C	80	28
Outlet Temperature	°C	60	43,66
Flow rate	l/h - l/h	1520,17	1915,20
Pressure drop	kPa	23,0	29,9
Fouling factor	(m ² K)/W	0	0
Velocity (Inside)	m/s	0,32	0,34
Exchange coefficient	W/(m ² K)	44095	37351
DTML	°C	34,12	

WARNING

No warnings

DIMENSIONS

Surface	m ²	0,3000	
Weight	kg	4	
Channel volume	dm ³	0,6	
Height	mm	310	
Width	mm	111	
Depth	mm	42,6	
Connections	mm	1" G	1" G

OFFER

Unit net price	Euro	
----------------	------	--

NOTES

--

DATA	17/09/2020
CUSTOMER	
REFERENCE	

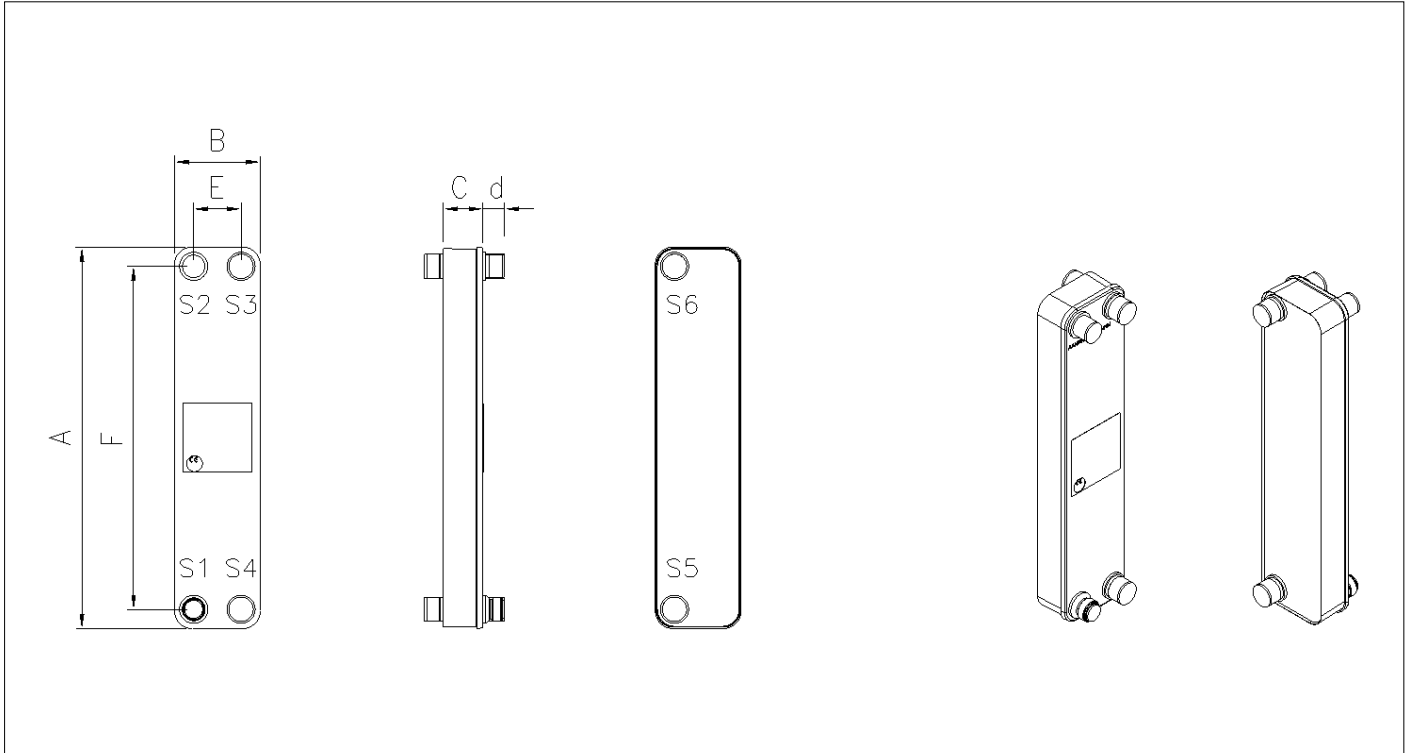
DRAWING

DIMENSIONS (mm)
DATA

A	310	S1	1" G	Surface	m ²	0,3000
B	111	S2	1" G	Weight	kg	4
C	42,6	S3	1" G			
E	50	S4	1" G			
F	250	S5	1" G			
G	--	S6	1" G			
d	24	S7	--			
		S8	--			