

FIREBIRD



HEATING SOLUTIONS

ENVIROMAX CONDENSING RANGE TECHNICAL MANUAL

For use with Diesel 35 Second Gas Oil

TECHNICAL MANUAL INCLUDES

- >> END USER INSTRUCTIONS
- >> INSTALLER GUIDE
- >> COMMISSIONING
- >> SERVICING
- >> PARTS



Working towards a greener planet

This manual must remain with the end user on completion of installation

	PAGE
1. FOREWORD & INTRODUCTION	2
2. TECHNICAL SPECIFICATIONS	
2.1 System Boiler	3
2.2 Kitchen (Basic) & Commercial Utility Boilers	4
2.3 Slimline Systempac Boiler	5
3. INSTALLATION IN NEW ZEALAND AND AUSTRALIA	6
4. SAFETY	7
5. END USER INSTRUCTIONS	
5.1 Operating procedure	8
5.2 Thermostat Control & Burner Lockout	9
6. INSTALLATION	
6.1 Guidelines	10
6.2 Positioning the Boilers	11
6.3 Condensate Disposal	12
6.4 Sealed System Heating Circuit	14
6.5 Flue Regulations	17
6.6 Ventilation & Combustion Air Requirements	21
6.7 Flue Assembly	25
6.8 Wiring	26
6.8.1 System Boiler	26
6.8.2. Kitchen (Basic) & Commercial Utility Boilers	27
6.8.3 Slimline Systempac Boiler	28
6.9 Oil Supply	29
7. COMMISSIONING	31
8. SERVICING	33
9. BURNER	
9.1 Burner Settings	34
9.2 G10 Blast Tube	35
9.3 Specifications	36
9.4 Fault Finding	37
10. PARTS & BAFFLES	
10.1 System Boiler	38
10.2 Kitchen (Basic) & Commercial Utility Boilers	40
10.3 Slimline Systempac Boiler	42
10.4 Burner	44
11. STANDARDS & REGULATIONS	46
12. TERMS & CONDITIONS OF WARRANTY	47
13. SERVICE RECORD	48
14. COMMISSIONING CARD	49

We would like to thank you for purchasing a high efficiency Firebird condensing domestic or commercial central heating boiler. This instruction manual is produced for the reference and guidance of qualified installation engineers such as those who are OFTEC registered. EU legislation governs the manufacture, operation and efficiency of all domestic central heating oil boilers. Our boilers and burners will be supplied as matched units tested and approved to OFTEC Standard OFS A100.

FIREBIRD Boilers are full manufacturing members of OFTEC (Oil Firing Technical Association) and are participating in its Boiler testing and approvals programme to comply with OFS A100 and EC Efficiency Directive.

You should ensure that all installation, servicing and commissioning works are carried out by a competent person, such as one registered by OFTEC. It should be noted that it is the responsibility of the Installer/Householder to ensure that the boiler is properly commissioned. Failure to do so may invalidate the boiler warranty.

SERVICING

The boiler requires servicing on an annual basis to ensure it maintains its efficiency, continues to perform reliably and as a regular check on its built-in safety features. It is important that servicing should be conducted by a competent engineer, such as one who is OFTEC trained and registered.

All appropriate OFTEC manuals and BS Standards should be studied and their requirements adhered to and used in conjunction with these instructions. This manual includes a list of some BS Standards and Building Regulations.

OFTEC is conducting training and registration of engineers and this is to be commended, as reading of this manual alone for installation and servicing procedures cannot replace the critical advantage provided by training and years of experience.

Firebird domestic or commercial condensing boilers are highly efficient and are all independently certified to SEDBUK Band A. They use less fuel and have lower running costs than non-condensing boilers. Because of their increased efficiency they emit less carbon dioxide than non-condensing boilers, which will contribute to efforts to reduce global warming. The incredible efficiency of the Firebird Condensing Boiler is due to the development of a single boiler unit with two unique heat exchanger units. This gives an exchange surface greater than non-condensing boilers.

This additional surface area increases the amount of heat extracted from the combustion process and thus reduces the heat wasted to atmosphere. So much heat is extracted from the combustion gases that their water vapor element condenses into liquid form, releasing the latent heat that was used to create the vapor in the first place. It is this heat gain that gives the condensing boiler its significant advantage over a non-condensing model. In order to enable this high level of heat extraction to take place, the water in the boiler's heat exchanger must be cooled down to about 55°C or less, this means that the boiler is working at its maximum efficiency.

The condensate produced is often mistakenly considered to be highly acidic. In fact the acidity of condensate from a Firebird Condensing Boiler will be found to be as low, if not lower, than that of vinegar.

The Firebird Condensing Boiler is suitable for under floor heating provided the return temperature is above 40°C. at all times.

The Firebird Condensing Boiler even when not working in condensing mode will still operate at extremely high efficiencies making it suitable for fitting to an existing heating system without alteration to the radiator sizes.

The burner is factory set for use with Diesel 35 Second Gas Oil. The burner will require commissioning as described in the commissioning section of this manual due to flue configurations and load conditions.

2 2.1 TECHNICAL SPECIFICATIONS - SYSTEM BOILER

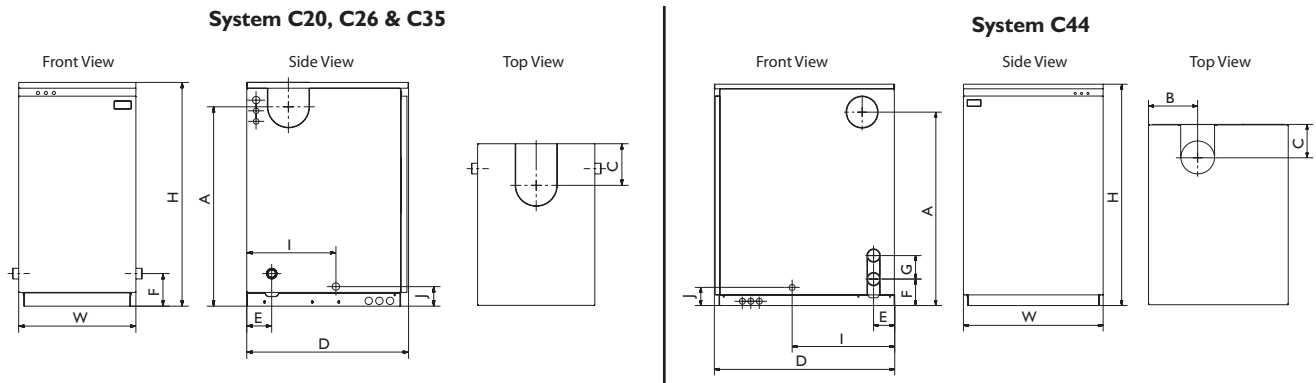

Model Enviromax	Output kW	Weight kg	Dimensions(mm)										
			H	W	D	A	B	C	E	F	G	I	J
System C20	15-20	143	847	442	610	753	-	157	94	124	-	336	75
System C26	20-26	146	847	442	610	753	-	157	94	124	-	336	75
System C35	26-35	149	847	442	610	753	-	157	94	124	-	336	75
System C44	35-44	235	1048	660	852	914	232	154	100	125	111	485	86

Use of copper pipe is recommended for a minimum of 1 metre off the boiler.

Boiler Model		C20 + C26	C35	C44
Heat Output	kW Max. BTU/h ('000)	15-20/20-26 50-90	26-35 90-120	35-44 120-150
CONNECTIONS				
Heating Flow		22 mm dia.	28 mm dia.	1 1/2" BSP
Heating Return		1" BSP	1" BSP	1 1/2" BSP
Mains Cold Feed (Copper)		15 mm dia.	15 mm dia.	15 mm dia.
Hot Water Delivery (Copper)		-	-	-
Drain Off Valve		1/2" BSP	1/2" BSP	1/2" BSP
Safety Pressure Valve Outlet (Copper)		15 mm dia.	15 mm dia.	15 mm dia.
Condensate Trap		22 mm dia. plastic	22 mm dia. plastic	22 mm dia. plastic
CIRCULATING PUMP				
Integral Expansion Vessel Normal Capacity		25/60	25/60	25/80
Expansion Vessel Pre-charge Pressure		12 litres	12 litres	18 litres
Low Pressure Water Switch?		1 bar	1 bar	1 bar
Filling Loop Included?		✓	✓	✓
WATER CONTENT				
Boiler		24 litres	24 litres	45 litres
Primary Tank		-	-	-
FLUE (Indoor Boilers)				
Balanced Flue Assembly		125 (5") mm dia.	125 (5") mm dia.	150 (6") mm dia.
Conventional Flue Assembly		80 id. mm dia.	80 id. mm dia.	100 id. mm dia.
Max. Low Level Flue Length		1.5m	1.5m	1.5m
Max. High Level Flue Length		6m	6m	6m
Max. Vertical Level Flue Length		6m	6m	6m
HEATING SYSTEM (SEALED)				
Max. Operating Pressure		Fit in accordance with BS 7074 Part 1, BS 5449, OFTEC standards and all other relevant legislation.		
Max. System Pressure Cold		2.5 bar		
Min. System Pressure Cold		1.5 bar		
Preset Pressure Relief Valve		0.5 bar		
		3 bar		
MAINS WATER SUPPLY PRESSURE				
		Min. 1 bar - Max. 10 bar (for user comfort, we recommend pressure at tap to be between 2 and 5 bar). Limescale excess: When over 150/200 ppm, fit appropriate scale reducer.		
WATER SIDE RESISTANCE				
Flow Rate To Give A Nominal Output At 10K Differential		20kW	26kW	35kW
Flow Rate Measured		1642 kg/h	2135 kg/h	2874 kg/h
Waterside Resistance		0.18 mbar	0.18 mbar	0.18 mbar
Flow Rate To Give A Nominal Output At 20K Differential				
Flow Rate Measured		870 kg/h	1131 kg/h	1523 kg/h
Waterside Resistance		0.19 mbar	0.19 mbar	0.19 mbar
PRESSURE JET OIL BURNERS FUEL ELECTRICAL SUPPLY		Riello RDB 2.2R Diesel 35 Second Gas Oil 230V AC 50Hz 5A		
TEMPERATURE CONTROL				
Boiler Central Heating Control		60°C - 80°C		
Boiler Safety Limit		110°C		
Over-run - Fixed		87°C		

2 2.2 TECHNICAL SPECIFICATIONS - KITCHEN (BASIC) & COMMERCIAL UTILITY BOILERS

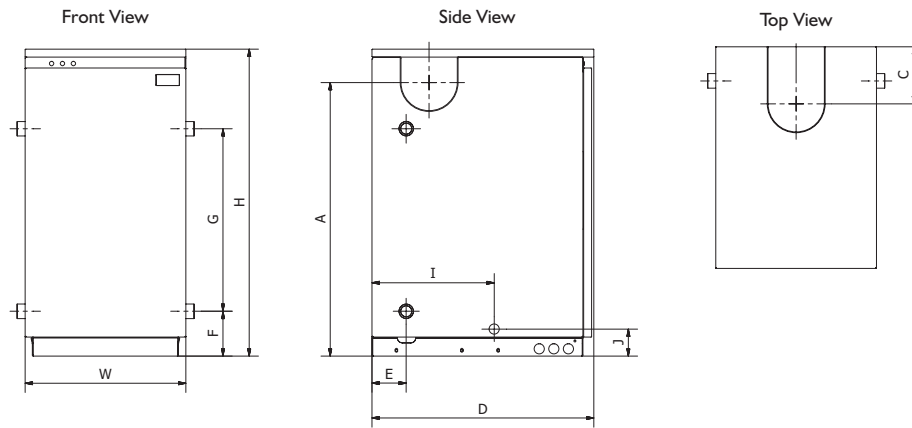

Model	Output kW	Weight kg	Dimensions(mm)									
			H	W	D	A	C	E	F	G	I	J
Kitchen (Basic) C12/18	12-18	115	847	345	610	753	157	94	124	502	336	75
Kitchen (Basic) C44	35-44	210	1048	464	852	914	154	100	130	615	485	86
Kitchen (Basic) C58	44-58	216	1048	464	852	914	154	100	130	615	485	86
Kitchen (Basic) C73	58-73	242	1196	524	851	1024	157	100	125	670	484	86
Commercial Utility	80-100	390	1249	623	1071	-	158	130	132	832	723	72

Use of copper pipe is recommended for a minimum of 1 metre off the boiler.

Boiler Model		C12/18	C44	C73	Commercial Utility
Heat Output	kW Max. BTU/h ('000)	12-18 40-60	35-44/44-58 120-200	58-73 200-250	80-100 270-340
CONNECTIONS					
Heating Flow		1" BSP	1 1/2" BSP	1 1/2" BSP	2" BSP
Heating Return		1" BSP	1 1/2" BSP	1 1/2" BSP	2" BSP
Drain Off Valve		1/2" BSP	1/2" BSP	1/2" BSP	1/2" BSP
Condensate Trap		22mm dia. plastic	22mm dia. plastic	22mm dia. plastic	22mm dia. plastic
WATER CONTENT					
Boiler		24 litres	43.5 litres	54 litres	75 litres
FLUE (Indoor Boilers)					
Balanced Flue Assembly		125 (5") mm dia.	150 (6") mm dia.	180 (7") mm dia.	200 (8") mm dia.
Conventional Flue Assembly		80 id. mm dia.	100 id. mm dia.	125 id. mm dia.	150 id. mm dia.
Max. Low Level Flue Length		1.5m	1.5m	1.5m	1.5m
Max. High Level Flue Length		6m	6m	6m	6m
Max. Vertical Level Flue Length		6m	6m	6m	6m
HEATING SYSTEM (SEALED)		Fit in accordance with BS 7074 Part 1, BS 5449, OFTEC standards and all other relevant legislation. Preset Pressure Relief Valve 3 bar			
MAINS WATER SUPPLY PRESSURE		Min. 1 bar - Max. 10 bar (for user comfort, we recommend pressure at tap to be between 2 and 5 bar). Limescale excess: When over 150/200 ppm, fit appropriate scale reducer.			
WATER SIDE RESISTANCE		20kW	26kW	35kW	
Flow Rate To Give A Nominal Output At 10K Differential					
Flow Rate Measured		1642 kg/h	2135 kg/h	2874 kg/h	
Waterside Resistance		0.18 mbar	0.18 mbar	0.18 mbar	
Flow Rate To Give A Nominal Output At 20K Differential					
Flow Rate Measured		870 kg/h	1131 kg/h	1523 kg/h	
Waterside Resistance		0.19 mbar	0.19 mbar	0.19 mbar	
PRESSURE JET OIL BURNERS		Riello RDB 2.2R up to C44 & Riello RDB 4.2 up to C100			
FUEL		C2 Kerosene			
ELECTRICAL SUPPLY		230V AC 50Hz 5A			
TEMPERATURE CONTROL					
Boiler Central Heating Control		60°C - 80°C			
Boiler Safety Limit		110°C			

2 2.3 TECHNICAL SPECIFICATIONS - SLIMLINE SYSTEMPAC BOILER

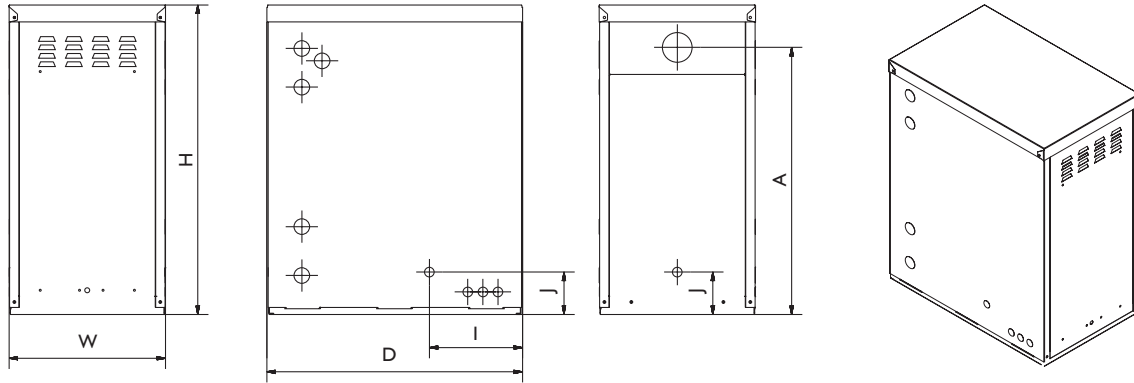

Model	Output kW	Weight kg	Dimensions					
			H	W	D	A	I	J
Enviromax Slimline Systempac C26	20-26	150	920	465	760	794	277	126
Enviromax Slimline Systempac C35	26-35	153	920	465	760	794	277	126

Use of copper pipe is recommended for a minimum of 1 metre off the boiler.

Boiler Model	C26	C35	
Heat Output kW Max. BTU/h ('000)	20-26 70-90	26-35 90-120	
CONNECTIONS			
Heating Flow	22 mm dia.	28 mm dia.	
Heating Return	1" BSP	1" BSP	
Mains Cold Feed (Copper)	15 mm dia.	15 mm dia.	
Hot Water Delivery (Copper)	-	-	
Drain Off Valve	1/2" BSP	1/2" BSP	
Safety Pressure Valve Outlet (Copper)	15 mm dia.	15 mm dia.	
Condensate Trap	22 mm dia. plastic	22 mm dia. plastic	
CIRCULATING PUMP			
Integral Expansion Vessel Normal Capacity	25/60	25/60	
Expansion Vessel Pre-charge Pressure	12 litres	12 litres	
Low Pressure Water Switch?	1 bar	1 bar	
Filling Loop Included?	✓	✓	
WATER CONTENT			
Boiler	24 litres	24 litres	
Primary Tank	-	-	
FLUE	Integral Flue	Integral Flue	
HEATING SYSTEM (SEALED)	Fit in accordance with BS 7074 Part 1, BS 5449, OFTEC standards and all other relevant legislation.		
Max. Operating Pressure	2.5 bar		
Max. System Pressure Cold	1.5 bar		
Min. System Pressure Cold	0.5 bar		
Preset Pressure Relief Valve	3 bar		
MAINS WATER SUPPLY PRESSURE	Min. 1 bar - Max. 10 bar (for user comfort, we recommend pressure at tap to be between 2 and 5 bar). Limescale excess: When over 150/200 ppm, fit appropriate scale reducer.		
WATER SIDE RESISTANCE	20kW	26kW	35kW
Flow Rate To Give A Nominal Output At 10K Differential			
Flow Rate Measured	1642 kg/h	2135 kg/h	2874 kg/h
Waterside Resistance	0.18 mbar	0.18 mbar	0.18 mbar
Flow Rate To Give A Nominal Output At 20K Differential			
Flow Rate Measured	870 kg/h	1131 kg/h	1523 kg/h
Waterside Resistance	0.19 mbar	0.19 mbar	0.19 mbar
PRESSURE JET OIL BURNERS	Riello RDB 2.2 R		
FUEL	Diesel 35 Second Gas Oil		
ELECTRICAL SUPPLY	230V AC 50Hz 5A		
TEMPERATURE CONTROL			
Boiler Central Heating Control	60°C - 80°C		
Boiler Safety Limit	110°C		
Over-run - Fixed	87°C		

3 INSTALLATION IN NEW ZEALAND & AUSTRALIA

This appliance has been manufactured in compliance with AS1690 Domestic Oil Fired appliances Safe Design Code.

This appliance has a current Occupational Safety and Health (OSH) and Environmental Risk Management Association (ERMA) Clean Air Approval number of BUR0801

This appliance and flue system has been tested by CRL Laboratories in New Zealand (**Certificate number 07-41180**) and can be installed to meet the requirements of AS1691-1985 Domestic Oil Fired Appliances Installation.

This includes suitability for zero clearance installation to combustible surfaces.

Please ensure that this appliance and flue system is installed to comply with manufacturers instructions and AS1691-1985 Domestic Oil fired Appliances Installation.

Please ensure that the appliance is bolted to the floor for seismic restraint.

Firebird recommend the use of Firebird coaxial flue systems to achieve room sealed operation. However, conventional flue systems are also suitable.

The installation of this appliance and fuel source will require a building consent from your local council.

THIS APPLIANCE IS TUNED TO RUN ON DIESEL FUEL.

This appliance must be installed by experienced personnel.
Failure to install correctly will invalidate the warranty.
The warranty does not cover consequential damages.

If you have any queries with this product, please consult:

**Central Heating New Zealand Ltd.,
52 Pilkington Way,
Wigram,
Christchurch 8042,
New Zealand.
Tel: +(0) 64 3357 1233
www.centralheating.co.nz**

HEALTH & SAFETY INFORMATION

Under the Consumer Protection Act 1987 (UK), section 6 of the Health and Safety Act 1974 (UK) and the Safety, Health and Welfare at Work Act 2005 (ROI), we are required to provide information on substances hazardous to health.

INSULATION AND SEALS

Ceramic Fibre, Alumino - Silicone Fibre material are used for boards, ropes and gaskets. Known hazards are that people may suffer reddening and itching of the skin. Fibre entering the eye will cause foreign body irritation. It may also cause irritation to the respiratory tract.

Precautions should be taken by people with a history of skin complaints or who may be particularly susceptible to irritation. High dust levels are only likely to arise following harsh abrasion. Suitable personal protective equipment should be worn where appropriate.

Generally, normal handling and use will not give discomfort. Follow good hygiene practices, wash hands before consuming food, drink or using the toilet.

First Aid - Medical attention should be sought following eye contact or prolonged reddening of the skin.

The small quantities of adhesives and sealants used in the product are cured. They present no known hazards when used in the manner for which they are intended.

THIS PRODUCT HAS BEEN DESIGNED TO THE FOLLOWING STANDARDS:

EMC Directive

(Electromagnetic compatibility) 89/336/EC

Standards:

EN 61000-6-1: Electromagnetic Compatibility Generic Standard - Immunity for residential, commercial and light industrial environments. (Feb.2001)

EN 61000-6-3: Electromagnetic Compatibility Generic Standard - Emission standard for residential, commercial and light industrial environments. (Feb.2001)

LV Directive

(Low voltage) 73/23/EEC

Standard:

IEC 60335-1: Household and similar electrical appliances - Safety (May 2001)

Boiler Efficiency Directive 92/42/EEC

Standard:

BSEN 304: Oil boilers with forced draft burners.

FUEL SPILLAGE

1. Switch off all electrical and other ignition sources.
2. Remove all contaminated clothing to safeguard against fire risk and skin damage. Wash affected skin thoroughly with soap and water and remove clothing to a safe well ventilated area and allow to air before cleaning.
3. Contain and smother the spill using sand or other suitable oil absorbent media or non-combustible material.
4. Do not allow fuel to escape into drains or water courses. If this happens, contact the relevant authorities in your area (Ireland).
Contact The Environment Agency on 0800 807060 (UK).
5. Consult local Authority about disposal of contaminated soil.

SAFETY

Safe use of Diesel.

These fuels give off a flammable vapour when heated moderately. Vapour ignites easily, burns intensely and may cause explosion. The vapour can follow along at ground level for considerable distances from open containers and spillages collecting as an explosive mixture in drains, cellars, etc.

Fuels remove natural oils and fats from the skin and this may cause irritation and cracking of skin. Barrier cream containing lanolin is highly recommended together with good personal hygiene and where necessary appropriate personal protection equipment (P.P.E.).

Gas oil may also cause irreversible damage to health on prolonged or repeated skin contact.

Always store fuels in a properly constructed and labelled tank. Always handle fuel in open air or well ventilated space away from sources of ignition and refrain from smoking.

Always drain fuel using a proper fuel retriever, funnel or mechanical siphon. Never apply heat to a fuel tank, container or pipework. Never siphon fuel through tube by mouth. If accidentally swallowed contact doctor immediately and do **NOT** induce vomiting. Avoid inhaling fuel vapour as this can cause light headedness and seriously impair judgement.

FIRST AID

If fuel is accidentally swallowed:

- * Seek medical attention immediately. Do **NOT** induce vomiting.

If fuel is splashed into eyes:

- * Wash out with running water for at least ten minutes and seek medical attention.

5 5.1 END USER INSTRUCTIONS - OPERATING PROCEDURE

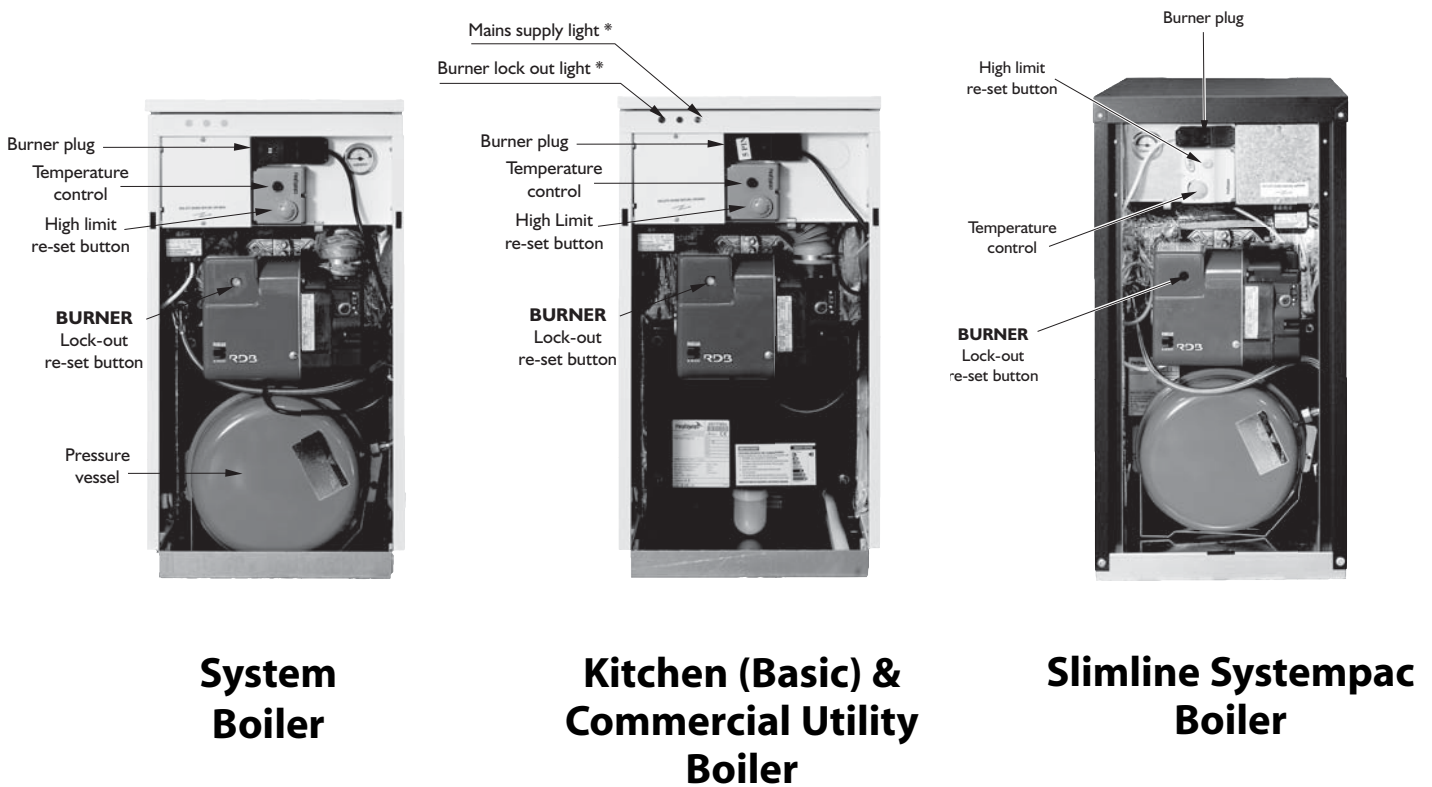

TO START THE BOILER:

- Turn on fuel supply.
- Switch on power supply to boiler.
- Turn the house heating control "ON" and increase the temperature to call for heat.
- Set the boiler thermostat to the required temperature (see Figure 1 on next page). The boiler thermostat controls the boiler operation by automatically maintaining the required boiler water temperature output. Safe operation is also maintained by the burner control system which provides the required ignition and shut off sequence. If a time control is fitted this will automatically switch the boiler off and on when heat is required.

TO TURN OFF THE BOILER:

- Turn the timer control (if fitted) to "OFF".
- Turn off the mains electrical supply to the boiler.

WATER TEMPERATURE THERMOSTAT CONTROL

Figure 1



BURNER LOCKOUT

(ALL MODELS)

The boiler is factory fitted with a burner control box lockout safety feature which operates automatically if a fault occurs in the burners operation. Should this occur, the red light on the front of the burner - **see burner section page 40 or boiler photo** - will illuminate and its cause must be investigated. This could be caused by:

- A.** An interruption in the fuel supply (eg. empty oil supply tank).
- B.** An electrical supply fault.
- C.** A fault with the burner or its safety control system.
- D.** The failure of a component (eg. photo cell).
- E.** Worn or dirty oil nozzle.

Before attempting to restart the boiler the front panel and the burner cover should be removed and a visual check made for any obvious problems such as oil leaks, loose connections etc.

**ENSURE OIL TANK CONTAINS CORRECT GRADE FUEL
DIESEL 35 SECOND GAS OIL**

TO RESTART THE BOILER:

- 1.** Press reset button see burner section or boiler photo.
- 2.** Ensure that the boiler thermostat, time switch (if fitted) and any external controls connected to the boiler are set to call for heat.
- 3.** Check that the oil supply valves and remote sensor fire valve are open and that there is sufficient oil in the tank.
- 4.** Check that the burner lockout light is unlit and with the mains on, the boiler will be ready to commence its start sequence.

6 6.1 - INSTALLATION - GUIDELINES

Please note the following important points before commencing installation. Failure to do so will invalidate warranty.

INSTALLATION & COMMISSIONING

Boilers must be installed, commissioned and serviced by qualified and experienced persons and as set out in the installation manual, using correct test equipment.

EXPANSION VESSEL

Total water content of system and boiler must be calculated to determine if an additional pressure vessel is required.

HARD WATER - LIMESCALE

Failure to check water hardness and fit appropriate water softening equipment will result in scale build up and consequent reduction in water heating performance. Check with local Water Authority if in doubt.

PLASTIC PIPING - WARNING

The boiler thermostat control and safety system is not designed, and must not be relied on, to protect plastic pipe from overheating. Plastic pipe is not recommended to be connected directly to the boiler. If you choose to use plastic pipe anywhere on your heating circuits, please consult the plastic pipe manufacturer for their instructions on how to ensure their product never overheats. Our boiler control and safety high limit thermostats are not designed to fulfil this function. (They may suggest the fitting of independent pipe thermostats, or thermostatic mixing valves linking flow and return).

• Firebird accepts no responsibility for failure of plastic piping and fittings for whatever reason.

WARNING

The manufacturer cannot accept responsibility for any damage to persons, animals or property due to error in installation or in the burner adjustment or due to improper or unreasonable use or non observance of the technical instruction enclosed with the burner, or due to the intervention of unqualified personnel.

BOILER THERMOSTAT / THERMISTOR FUNCTION

The control thermostat [1] on the boiler allows the householder to vary the water flow temperature from a low of 60°C to a high of 80°C to 82°C, depending on the model.

In accordance with EU boiler standards, your boiler is also fitted with a safety high limit thermostat [2], fixed at 114°C. This system protects the boiler in the event of the control thermostat failing and keeps the boiler safe.

The safety high limit thermostat [2] will shut off the boiler and will require the limit button to be pushed to restart the boiler. If the problem re-occurs, you should call your service engineer.

In cases where the flow from the boiler is immediately in a downstream direction to the heating system, fitting a pump over run thermostat [3] (a pipe stat) is recommended. This is to prevent the residual heat build up in the boiler from unnecessarily activating the high limit thermostat and thus causing nuisance. See Slimline Systempac wiring diagram.

Factory fitted pump overrun thermostats are fitted to the System and Slimline Systempac boilers.

TIME AND TEMPERATURE CONTROLS

The Building Regulations state that central heating systems must have time and temperature control on the pipe circuits (eg thermostatic radiator valves / TRVs, room thermostats, cylinder thermostats etc.).

BURNER

The burner is factory set for use with Diesel 35 Second Gas Oil.

ROOM SEALED BALANCED FLUES

BS 5410 Part 1: 2014 - Code of Practice for Oil Firing - Installation up to 44kW Output Capacity for Space Heating and Hot Water Supply Purposes - Paragraph 11.2 Mounting.

The flue terminal should be mounted so that it is separated from any combustible material forming a part of the building.

Such combustible material may take the form of cladding on the surface of a non-combustible wall through which the flue outlet passes. Refer to Zero Clearance Test Report by Central Heating New Zealand.

The wall through which the flue outlet passes may itself be of combustible material, and if so, the flue outlet, where it passes through the wall, should be surrounded by non-combustible insulating material not less than 50mm thick. The insulating material itself should be contained in a steel liner to provide the necessary structural rigidity and to prevent moisture reaching the insulating material.

6 6.2 - INSTALLATION - POSITIONING THE BOILER

Ensure that adequate clearance is available for making the water and flue connections.

As the boiler is serviced from the front, no headroom clearance is necessary but a clearance of 750mm must be available at the front of the boiler.

No special hearth is required as the boiler is fully insulated and has been certified as a zero clearance appliance, but the floor must be level and capable of supporting the weight of the boiler and its water content.

Sound levels must also be a consideration. Whilst Firebird Enviromax boilers are one of the quietest boilers on the market, some end users are particularly sensitive and the following points should be considered:

1. Tiled surfaces in a small room will amplify noise - particularly if the wall construction is hollow.
2. If a conventional flue passes through a bedroom it is capable of transmitting noise.
3. Low level balanced flue terminals can produce exhaust noise on the outside terminal and this should be considered when siting near adjacent property.
4. The Firebird Balanced Flue Kit has been specifically designed for Firebird's indoor boilers. The use of third party low level flue kits is not recommended and will affect its warranty.
5. The Siting of the boiler should take into account the disposal of condensate products.

- It is mandatory that a suitable corrosion inhibitor is added to the heating system e.g. Fernox.
- New and existing systems should be treated with chemical cleaner and properly flushed before the boiler is fitted and corrosion inhibitor added.
- In areas of hard water a suitable descaler would also be required.

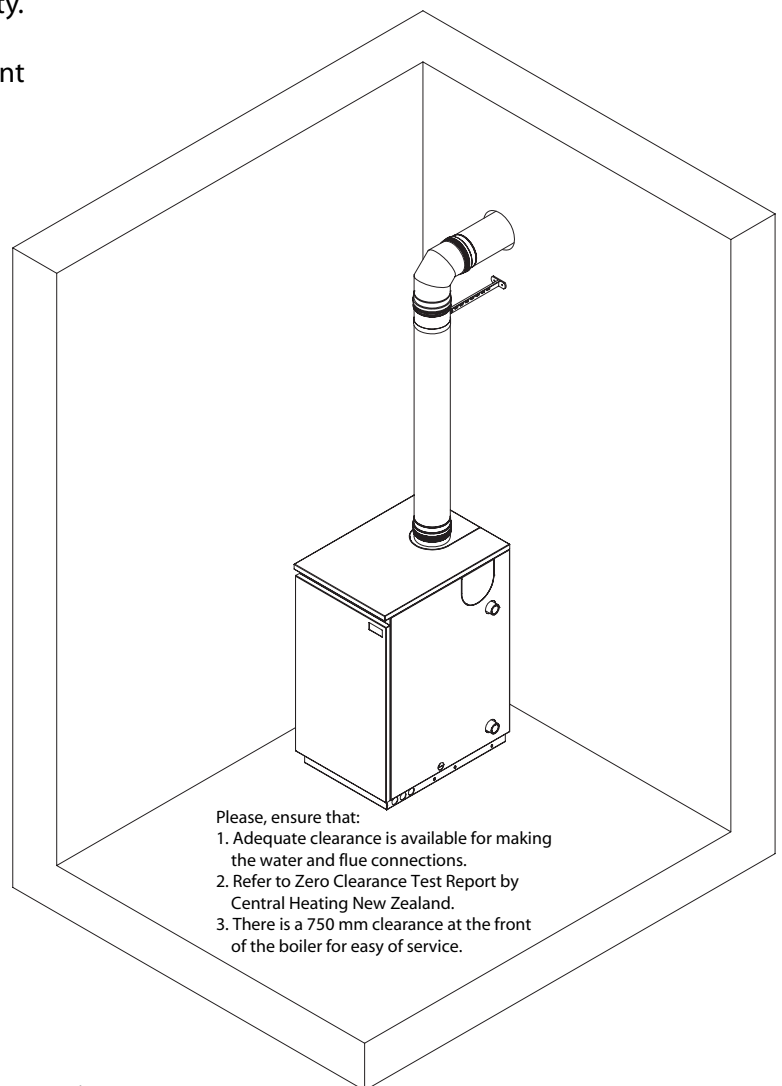

Figure 1

CONDENSATE DISPOSAL
METHOD 1
CONDENSATE TRAP

IMPORTANT
Always prime condensate trap with water.

Figure 1



Condensate baffle and condensate trap

Before switching on your Firebird condensing oil boiler check that:

- (1) The float & condensate drain baffle are in place.
- (2) That the condensate trap is primed.
- (3) The condensate discharge pipe is a corrosion resistant pipe.

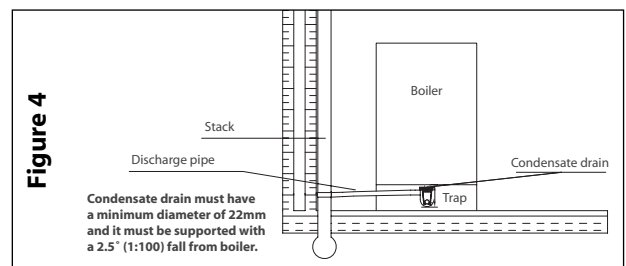
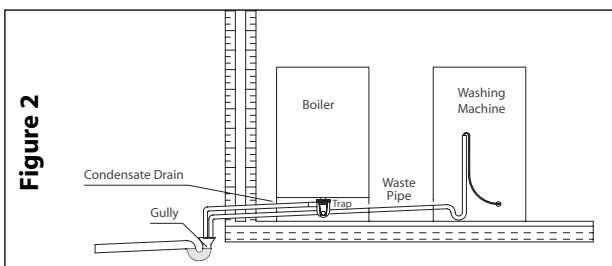
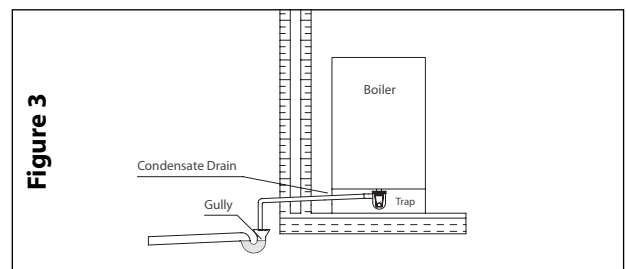
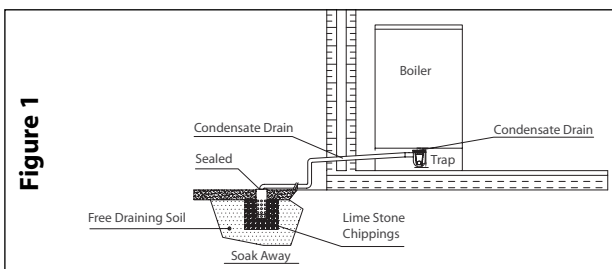
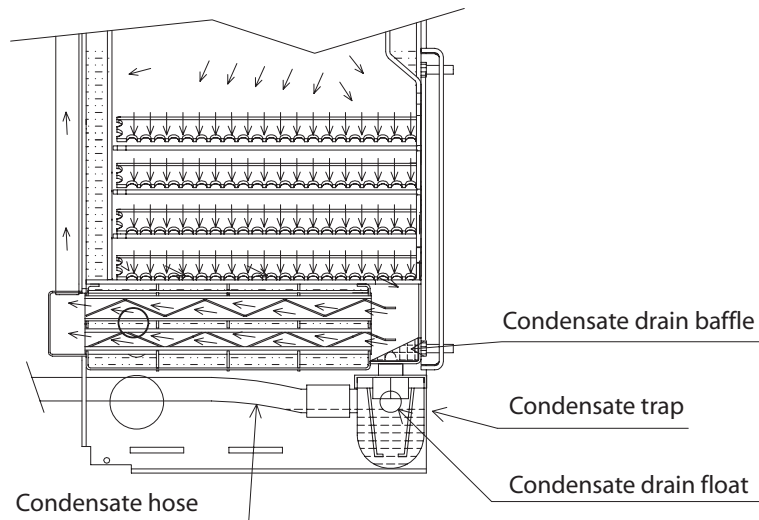

6 6.3 INSTALLATION - CONDENSATE DISPOSAL

CONDENSATE DISPOSAL METHOD 2 - CONDENSATE PUMP IMPORTANT

Firebird condensing boilers when in condensing mode extract more heat from the flue products and the resulting condensate which is mildly acidic needs to be drained from the boiler via a condensate pipe to the drainage system.

Provision must be made for the removal of condensate from the boiler to a internal soil stack, waste pipe, external soil stack, gully or soak-away as per BS6798.

The 75mm trap is provided with the boiler and situated on the front of the boiler (under the cleaning door). This should be checked at regular intervals and cleaned at annual service.

The condensate line should be plastic and minimum diameter of 22mm.

Copper or steel cannot be used.

A fall from the boiler of 1:100 minimum.

As few bends as possible to reduce the risk of trapping condensate.

CONDENSATE PIPEWORK THAT IS EXTERNAL OR IN AN UNHEATED GARAGE SHOULD NOT EXCEED 3 METERS AND LAGGED WITH WATER PROOF INSULATION TO PREVENT FREEZING.

CONDENSATE PUMP (KIT IS AVAILABLE AS AN OPTIONAL EXTRA)

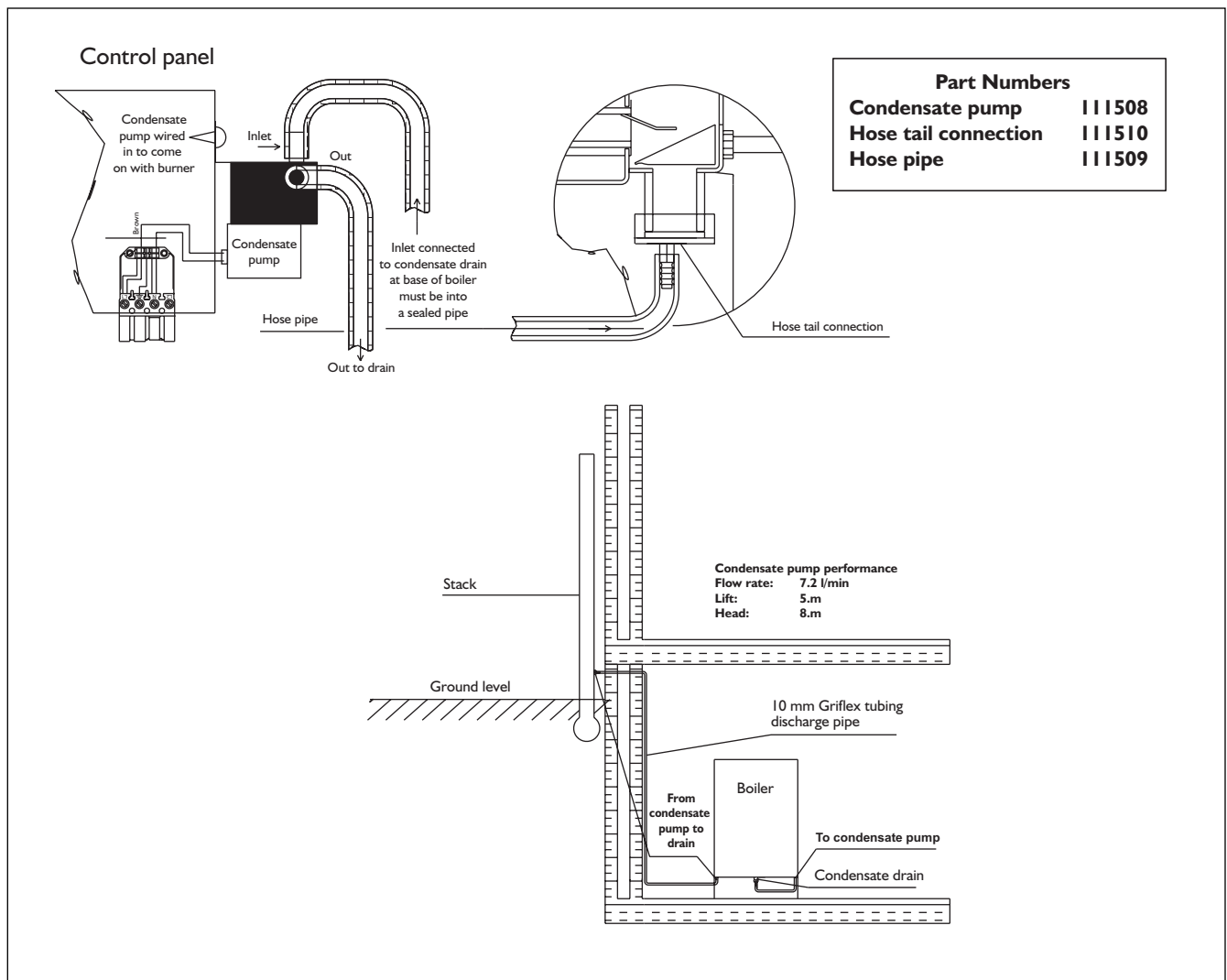

6 6.4 INSTALLATION - SEALED SYSTEM HEATING CIRCUIT

SEALED HEATING CIRCUIT

The system must comply with BS 7074 Part 1 and BS 5449 Part 1 with a maximum water temperature of 80°C.

- * A manual reset overheat limit thermostat is located at the rear of the electrical control panel. If a boiler overheat condition arises the burner will stop and remain inoperative until this thermostat reset button is depressed.

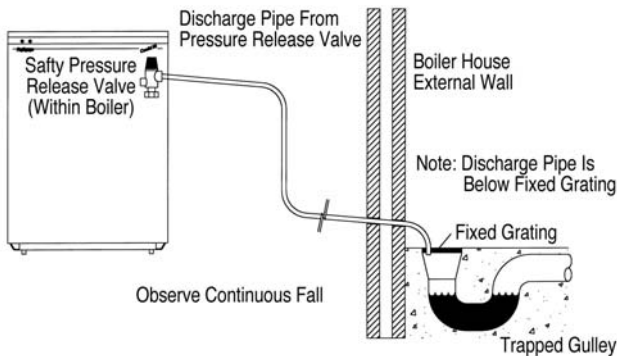

- * A pressure relief valve to BS 6759 operating at 3 bar (45 lb/in²) is fitted. A discharge pipe of 15 mm diameter is also fitted to the discharge connection on the pressure relief valve. During installation an extension pipe should be fitted to this, leading, to outside the building. The pipe should be as short as possible and may need a tundish fitted in a protected position within the building.

Note:- Water must not discharge above an entrance, window or where public have access. The installer must be aware that the discharge may be boiling water.

- * A drain valve must be fitted at the lowest points in the system to enable draining as necessary. A drain valve is already fitted at the bottom of the boiler to enable draining of boiler and tank unit only. All pipes connected to boiler should have shut off valves fitted to facilitate this.
- * A Pressure gauge, having range 0 to 4 bar is fitted to boiler control panel. This indicates water pressure in boiler and system at time of reading. **Pressure when cold should** be 1/2 bar minimum to 1.5 bar maximum. This is known as Initial System Design Pressure (P_i).

N.B. Initial System Design Pressure (measured in bar) equals static head of system (measured in bar) plus 0.3.



When the system is cold and filled to initial fill pressure P_i the pointer on the pressure gauge should point at **1 bar**.

The pressure gauge shown has **two red zones** marked on it. The first is between 0 and 1/2 a Bar. If the pointer falls into this zone when system and boiler are cold this is indicating that initial System Fill Pressure has dropped and this will activate the pressure switch cutting off power supply to the Combi C. Refill system manually until indicated pressure rises to 1 bar.

N.B. Insufficient pressure in the boiler will cause power supply to switch off.

- * A 12 litre expansion vessel is fitted to boiler, precharged with air or nitrogen to **1 bar** which allows a system static head of 5 metres. If the static head is greater than this then the air charge in the vessel must be increased to balance the higher static head. **The air charge should not exceed a pressure of 1.5 bar.**

If static head is altered then it is also necessary to alter air charge pressure to equal static head (+ 0.3 Bar). This is necessary in order to keep system water from entering expansion vessel until system is being heated and thus allow its maximum acceptance volume (V) to be used **only to accommodate the expansion of system water during boiler operation.**

Remember that air charge pressure **must** be **equal** in both vessels (attached to the same system). In the above example this is 1 bar. **Air charge pressure** is the air pressure in expansion vessel **before** system is filled. It is measured with a tyre gauge attached to Schrader valve on the vessel.

- N.B. The second **red zone** is between 2 1/2 and 4 bar pressure. When the heating system is up to full working temperature, if the pointer on the pressure gauge should enter this **red zone** showing a final system design pressure of more than **2 1/2 bar**, it is likely that:

- Total** system water content is greater than that calculated and if additional expansion vessel has been fitted it should be replaced with a larger unit
OR if integral boiler expansion vessel only is used then an additional expansion vessel is required.

6 6.4 INSTALLATION - SEALED SYSTEM HEATING CIRCUIT

- (b) Static head may be higher than calculated. In this case it is necessary to re-measure static head and revise expansion vessel air charge pressure.
- (c) Expansion vessel incorrect size or air charge pressure incorrect.

**Refer to BS 7074
Part 1 and BS 5449 for further information.**

EXPANSION VESSEL AND SYSTEM REQUIREMENTS

Safety Valve Setting	3 bar		
Initial System Pressure	0.5 bar	1.0 bar	1.5 bar
Total Water Content of System	TOTAL VESSEL VOLUME **		
Litres	Litres	Litres	Litres
25	2.1	2.7	3.9
50	4.2	5.4	7.8
75	6.3	8.2	11.7
100	8.3	10.9	15.6
125	10.4	13.6	19.5
150	12.5	-> [16.3] <-	23.4
175	14.7	19.1	27.2
200	16.7	21.8	31.2
225	18.7	24.5	35.1
250	20.8	27.2	39.0

**FOR FURTHER INFORMATION CONSULT
APPROPRIATE TRAINING MANUALS
AND BS 7074 PART 1, BS 5449, ETC**

* * When calculating size of any additional expansion vessel required, remember to deduct the boiler expansion vessel volume of 12 litres from the calculated total system vessel volume required, as given in above table.

EXAMPLE: using above table

If total water content of system is - **150 litres**
and initial system pressure required is - **1.0 bar**
then vessel volume required is - **16.3 litres**
[from above table]
The vessel supplied with boiler is - **12.0 litres**
therefore an additional vessel of - **4.3 litres**
is required (minimum)

(For this system of 150 litres - total water volume)

Nearest available stock size for additional vessel required, at 1 bar initial system pressure (taken from above table) is 5 Litres.

It is emphasised that the installer should be fully acquainted with sealed system installation and operation, calculation of total system water volume, determining of initial system pressure required and calculation of any additional expansion vessel volume required. **Warranty is void when the boiler is installed in a system with insufficient expansions.**

NB. Ensure that all expansion vessels in the same system are set at EQUAL air charge pressures.

SYSTEM FILLING, TESTING AND MAKE-UP

Introduction

Mains cold water is supplied through the boiler drain/fill valve.

Heating Circuit

This is the radiator heating system including the boiler which is filled from the mains supply via a flex filling loop to a pressure determined from the system static head, expansion vessel size and system water volume. This flexible filling loop should be disconnected when boiler and system are filled and checked (see method B).

System filling should take place slowly and can be completed via the following method:

Automatic Filling

Automatic System filling may be made with a feed and make-up cistern connected through a double check valve and stop valve assembly to the return side of the heating system as close to the boiler as is practical. This cistern should be located above the heating systems highest point to give a minimum static head of 300 mm between it (highest point) and cistern. The manual filling system fitted to boiler should then be disconnected and connection points blanked off.

This system has the advantage of automatic water make-up in the event of system pressure loss due to air elimination and minor leaks. In any case control panel pressure gauge should be occasionally checked.

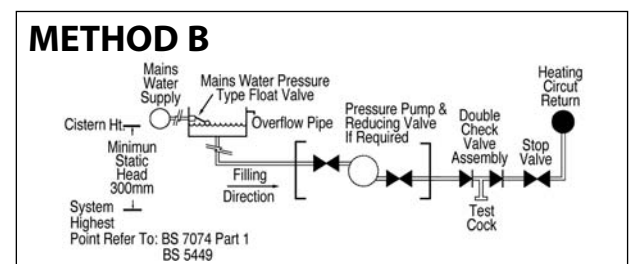

6 6.4 INSTALLATION - SEALED SYSTEM HEATING CIRCUIT

N.B. Remember also to check air fill pressure of Expansion Vessel when system is cold using standard tyre gauge connected to Schrader air valve on vessel.

NOTE: There shall be no direct connection to the mains, even with the use of a non-return valve without the permission of Local Water Authority.

* It is recommended that an inhibitor be added at the time of final fill to protect the System from corrosion. Ensure that this is carried out in accordance with inhibitor manufacturers instructions. Installer should ensure that inhibitor used is suitable and that it will have no adverse effect on Expansion Vessels diaphragms or any other part or component of the system.

COMMISSIONING

* Before proceeding to filling, ensure that electricity supply is switched off at mains to avoid any possibility of time switch operating and passing power to appliance prior to filling.

Filling and Testing

Check that all connections, especially compression joints, are fully tightened. Re-check and ensure that pressure vessel air charge is correct, then fill system with water via filling system used. **Turn off water supply before system pressure reaches safety valve operation point of 3 bar.** (Say 2 to 2.5 bar). Vent system via all manual air vents **including circulating pumps, boiler, radiators, system high points.** etc. Check that dust caps are loosened on auto air vents, keep constant check on system pressure gauge (fitted to control panel). If pressure has dropped re-admit water to above pressure. Ensure all appropriate boiler and system valves are open.

With water supply turned off, **thoroughly** flush out boiler and system to remove **all** foreign matter before allowing boiler and pumps to operate. If in doubt drain system and repeat above procedure. At this stage flushing-out water should be clean and clear of all foreign matter.

Refill the system and again vent at all points as described above. Examine the complete system for water leaks having pressurised it to 1 - 2.5 bar. Correct any leaks, then check operation of safety valve by admitting further water until this valve operates. This should occur when system pressure rises to between 2.7 and 3.3 bar. When satisfied with valve operation, and with mains water still turned off, draw off sufficient water until initial system design fill pressure (P_f). (cold fill) is established (0.5 - 1 bar - as calculated for system).

Remember that initial cold fill pressure can only be checked when system water has properly cooled down. Check that **final operating pressure** (P_f) is under 2.5 bar with all radiators turned on and up to highest working temperature. Should system operating pressure exceed this, check:



1. That initial cold fill pressure is correct and , if additional expansion vessel is fitted, that pressure is equal in each vessel.
2. That expansion vessels are sized correctly.

Special attention should be given to existing heating systems where a Firebird boiler has replaced an existing unit. Extra effort should be made to ensure that all original pipe work and radiators are repeatedly flushed. If possible use a proprietary cleansing agent suitable for system as loosened scale and foreign matter can seriously reduce domestic hot water performance and pump efficiency.

Use corrosion inhibitor of suitable type.

BALANCED FLUE SITING

- A. Horizontal from opening, airbrick, opening window etc.
- B. From an internal or external corner.
- C. Below an opening, airbrick, opening window etc.

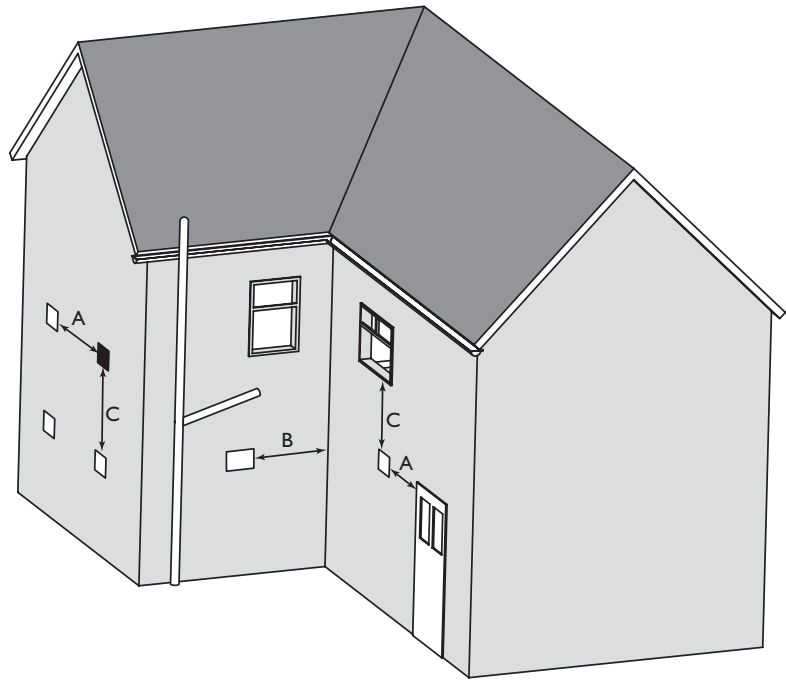

Information supplied by 
 Book 3 2010
See note at foot of page

- Notes:
1. The terminal should be positioned to avoid combustion products entering the building or accumulating in stagnant pockets around buildings.
 2. The terminal must be protected by a guard if it is less than 2 metres above ground level or in a position where any person has access to it (i.e. a balcony).
 3. A heat protection shield should be fitted if the terminal is less than 850mm from a plastic or painted gutter or less than 450mm from painted eaves.
 4. Prevailing winds should be taken into account when siting a flue.

* **FIREBIRD RECOMMENDS AS PER OFTEC RECOMMENDATIONS, THAT THE FLUE SHOULD BE A MINIMUM DISTANCE OF 1 METRE FROM OPENINGS SO THAT IT DOES NOT CAUSE A NUISANCE AND PERMITS THE DISPERSAL OF COMBUSTION PRODUCTS (SEE PAGE 18).**

Building Regulations

BUILDING REGULATIONS	A	B	C
Northern Ireland 2000	600	600	600
Republic of Ireland 1997	600	600	600

*Where the terminal is within 1 metre of any plastic material, such material should be protected from the effects of combustion products of fuel. There are additional general requirements in most Regulations and Standards that the flue must be positioned so that it does not cause a nuisance and permits the dispersal of combustion products.

NOTE: The Building Regulations clearances shown above are the minimum allowed. To take account of prevailing site conditions, it is advisable wherever necessary, to follow the manufacturer's preferred recommendation. If in doubt contact the manufacturer for advice.

ALWAYS CHECK FOR ANY BUILDING REGULATIONS AMENDMENTS WHICH MAY HAVE BEEN ISSUED AFTER THE PUBLICATION OF THIS MANUAL

6 6.5 INSTALLATION - FLUE REGULATIONS

Clearances advised by BS 5410 Part 1: 2014

Regular Appliance (Open, Low Level Discharge and Balanced) Flue Termination Clearance

The basic requirement with regard to flue positioning is that no hazard or nuisance is caused by the flue gases. Diagrams 20a and 20b show clearances advised by BS 5410 Part 1: 2014.

Regional requirements where flue clearances differ can be found in the regional requirements section in OFTEC Book 3 2010

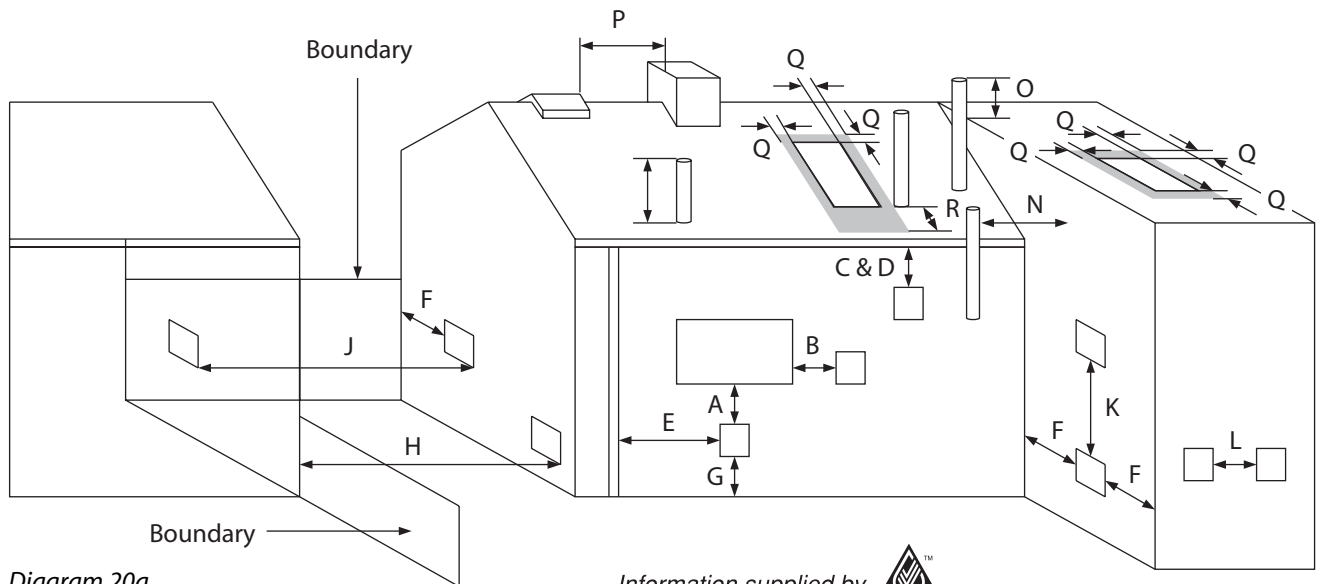



Diagram 20a

Information supplied by 

Minimum distances to terminals in millimeters as measured from the top of the chimney or the outer edge of where flue gases pass through low level discharge openings

	Location	Appliance Burner Type
		Pressure Jet Condensing
A	Directly below an opening, airbrick, opening window etc.	1000
B	Horizontally to an opening, airbrick, opening window etc.	1000
C	Below a gutter, eaves or balcony with protection	1000
D	Below a gutter or a balcony without protection	1000
E	From vertical sanitary pipe work	300
F	From an internal or external corner or surface or boundary alongside the terminal	300
G	Above ground or balcony level	300
H	From a surface or a boundary facing the terminal	2500
J	From a terminal facing the terminal	1200
K	Vertically from a terminal on the same wall	1500
L	Horizontally from a terminal on the same wall	750
M	Above the highest point of an intersection with the roof	600
N	From a vertical structure on the side of the terminal	750
O	Above a vertical structure less than 750mm from the side of the terminal	600
P	From a ridge terminal to a vertical structure on the roof	1500
Q	Above or to the side of any opening on a flat or sloping roof	300
R	Below any opening on a sloping roof	1000

SEE NEXT PAGE FOR IMPORTANT NOTES

6 6.5 INSTALLATION - FLUE REGULATIONS

NOTES: These notes form an integral part of the information shown on the previous page.

1. Terminals should be positioned to avoid products of combustion accumulating in stagnant pockets around the building, or entering into buildings.
2. Appliances burning Class D oil have additional restrictions (see OFTEC Book 3 2010).
3. Vertical structures in N, O and P include tank or lift rooms, parapets, dormers etc.
4. Terminating positions A to L are only permitted for appliances that have been approved for low level flue and low level balanced flue discharge when tested to BS EN 303-1.
5. Terminating positions must be at least 1.8m distant from an oil storage tank unless a wall with at least 30 minutes fire resistance and extending 300mm higher and wider than the oil storage tank is provided between the oil storage tank and the terminating position.
6. Where a flue is terminated less than 1m away from a projection above it and the projection consists of plastic or has a combustible or painted surface, then a heat shield of at least 750mm wide should be fitted to protect these surfaces.
7. For terminals used with vaporising burners, a horizontal distance of at least 2300mm is required between the terminal and the roof line.
8. If the lowest part of the terminal is less than 2m above the ground, balcony, flat roof or other place to which any person has access, the terminal must be protected by a guard.
9. Notwithstanding the dimensions given in the diagram and table, a terminal should not be sited closer than 300mm to combustible material.
10. It is essential that a flue or chimney does not pass through the roof within the shaded area shown by dimensions Q and R.
11. Where protection is provided for plastic components, such as guttering, it is essential that this is to the standard specified by the manufacturer of the plastic components.

Diagram 20b

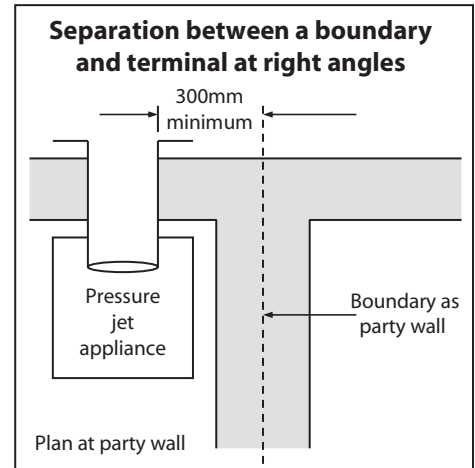

BALANCED FLUE BOILERS

The Firebird boiler may be set for room-sealed flue operation using a Firebird condensing balanced flue kit. This kit does **not** draw **combustion air** from inside the room. **It is drawn from outside, direct to the burner by an air pipe supplied with the boiler.** Flue gases are expelled through the same kit. However, if the boiler is installed in a **compartment** or **small room**, some **ventilation air** is necessary to maintain an acceptable temperature in the boiler area.

Balanced flue boiler in room (eg. kitchen) does not require individual ventilation.

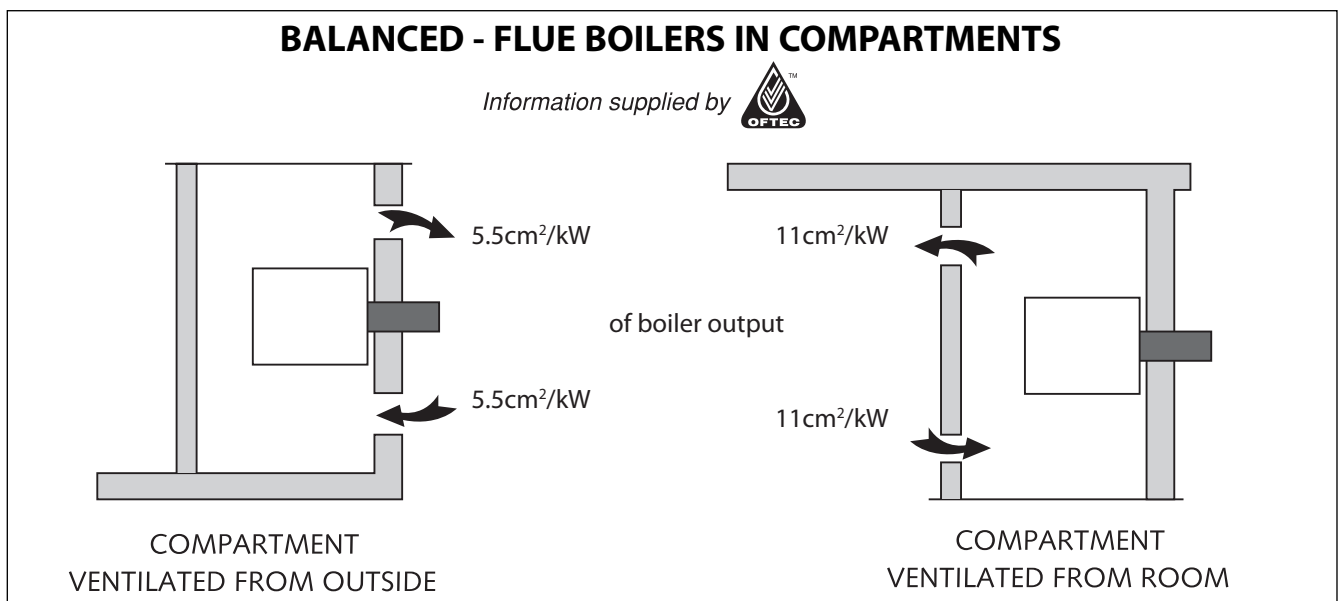

6 6.5 INSTALLATION - FLUE REGULATIONS

Ventilation and Combustion Air

Conventional Flue Boilers

An adequate supply of **combustion and ventilation air** is essential for efficient and safe boiler operation and the openings for this should be positioned to cause least possible draught, **with no possibility of being accidentally blocked**.

Please note: The British Standard Code of Practice for Oil Firing BS 5410 Part 1: 2014, requires a permanent air inlet opening of **5.5cm² per kW** of boiler rated output. (Note: 1kW = 3412 BTU/h).

Also, when the boiler is installed in a compartment or confined space, **ventilation** openings are required to ventilate and to avoid overheating in the boiler area.

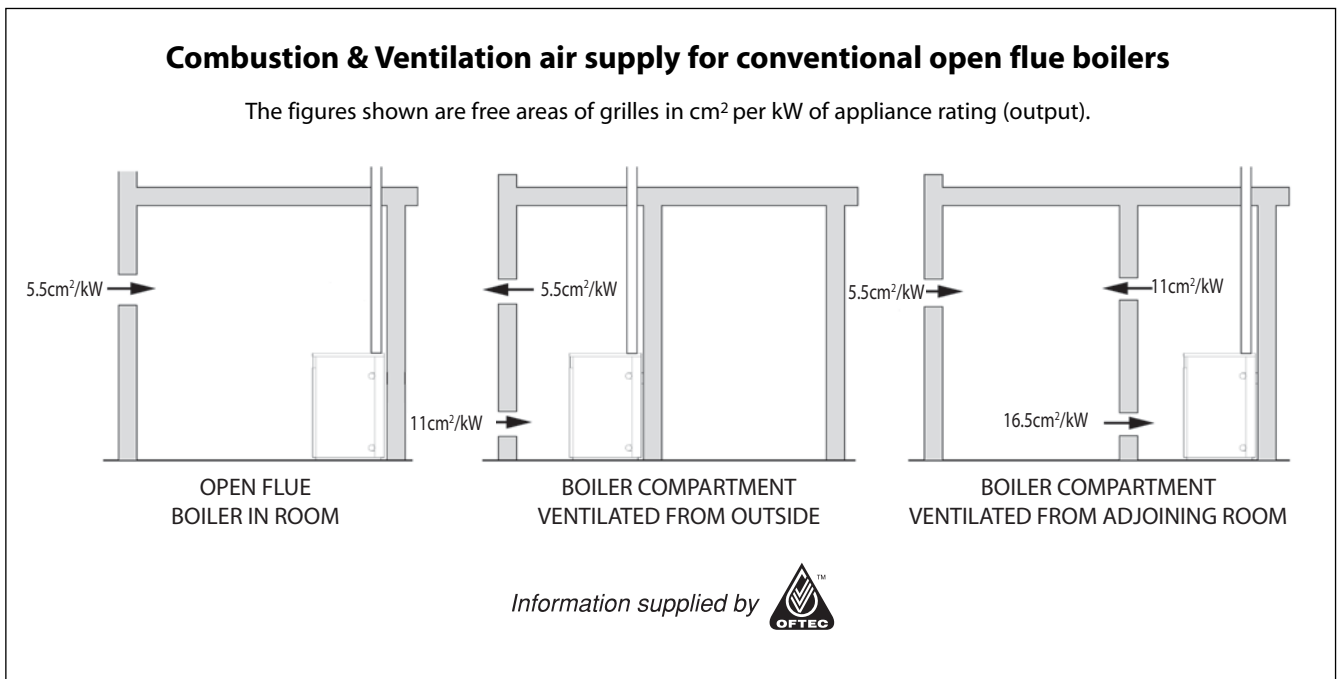

FULL TEXT of both BS 5410 Part 1: 2014 and appropriate Building Regulations for each country should be obtained and fully applied.

N.B. Please note:

BS 5410-1:2014 only permits room sealed boilers to be sited within garages.

Definitions

Combustion Air: Air required directly by boiler oil burner for combustion process.

Ventilation Air: Air required in room for ventilation, cooling, etc. and to promote a healthy living environment.

FIREBIRD ENVIROMAX BALANCED FLUE SYSTEMS

Vertical balanced flue kit - max flue length 6 m

Low level balanced flue kit - max length 3 m

High level balanced flue kit - max length 6 m

Overall length must take into account bends
where 45° bend = 0.5 m length and
90° bend = 1 m length

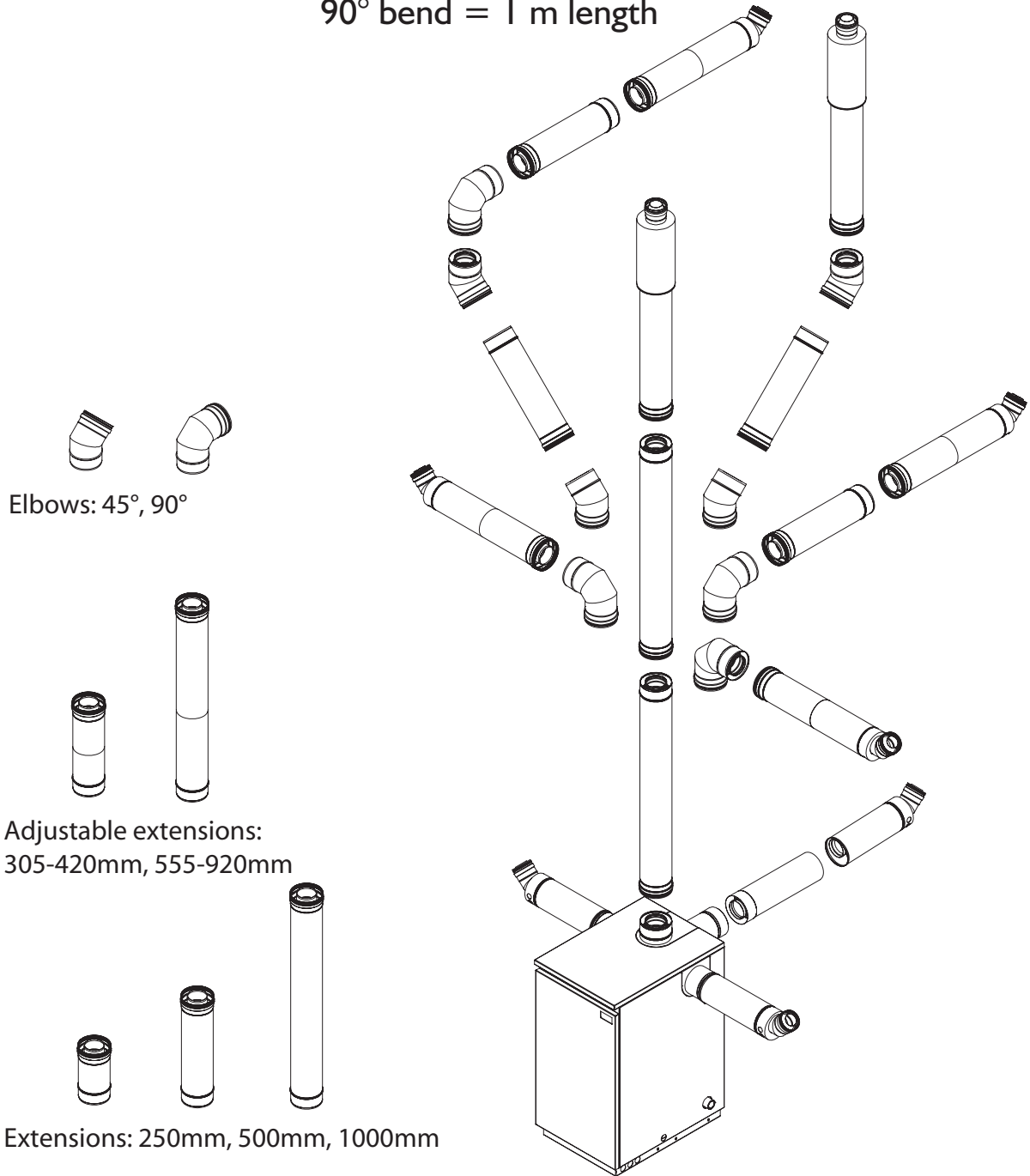

INSTALLATION INSTRUCTIONS SUPPLIED WITH ALL FLUE KITS



CONDENSATE PLUME DISPERSAL

When choosing the location for a condensing boiler, special consideration must be given to the positioning of the flue terminal. Care should be taken to locate it so as to prevent either the end user or their neighbours perceiving the plume to be a nuisance.

It should be noted that the normal statutory clearances required around low level flue terminals (ref. T45 T1/135) may not be sufficient to cope with plume dispersal from a condensing boiler. The following points should be considered:

1. Plumes can extend out horizontally and can also drift out to the sides and above the terminal. Care needs to be taken, therefore, to avoid the plume reaching adjacent surfaces, particularly windows and neighbours dwellings.
2. Flue terminals need to be located where air can pass freely across them to disperse vapours.
3. The effect of the moisture generated must be considered in relation to the possible corrosion of metal parts it might reach and to the possible formation of ice on pathways in freezing conditions.
4. Keep flue terminals a minimum of 1 m (horizontally) from openings in the building.
5. Do not install flue terminals directly below a window.
6. Do not install flue terminals next to a door.
7. Do not install flue terminals within 1 m of ventilated soffits or eaves.
8. Keep flue terminals at least 1 m away from a surface or boundary facing the terminal.
9. Follow the appliance manufacture's instructions.

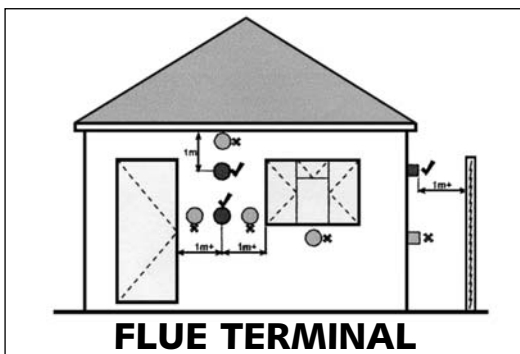

CONVENTIONAL FLUE SYSTEMS

IMPORTANT

The Firebird condensing boiler **must not** be installed with existing flue systems. A flue system suitable for wet flues must be used. If a flue system which is unsuitable is used it **will invalidate the warranty**.

Because of the high operating efficiencies of the Firebird condensing boilers and low flue gas temperatures, it is necessary to pay extra special attention to the flues and chimneys.

Existing chimneys must be lined with a liner certified as suitable for condensing oil boilers by flue manufacturer.

Twin wall insulation must be used for external applications, with **seals** and stainless steel inner skin.

Only vitreous enamel or high grade stainless steel can be used between boiler and chimney in an internal installation, aluminium or asbestos type material **must not be used (Vitreous enamel must not be cut)**.

Condensate must be able to run back into the flue chamber of the boiler and not escape, as up to 1.5 ltr. of condensate can be produced in a conventional flue. No trap is required in the flue system.

The terminal must be positioned to avoid combustion products entering the building and as per Building Regulations. **Refer to BS5410 Part 1: 2014 OFTEC installation requirements Book 4.**

Every individual concerned with any aspect of installation should be deemed as competent, and be aware of all current National and Local Government Standards and Building & Installation Regulations.

PLUME DISPERSAL KITS

Plume should be considered, for both low level and Slimline Systempac installations, under the following situations where low level terminal siting does not comply:

1. Building Regulations - as per diagrams in Firebird/OFTEC manuals.
2. Nuisance near a door, window or BBQ decking area.
3. Funnelling – when the boiler is less than 3m from a building/boundary i.e. in a narrow alley/corridor, where there is a high risk of this occurring.
4. In a corner where the wind can move in a whirlpool.
5. Flue facing into the prevailing wind.
6. Finally, if an installer feels that the location warrants a plume based on experience.

6 6.6 INSTALLATION - VENTILATION & COMBUSTION AIR REQUIREMENTS

It is necessary to ensure when the plumber is installing the flue that he:

- carries out a check of the existing flue;
- ensures all seals on the existing flue are in tact;
- removes the tapered section (cone) on the low level kit, insets the 3 lip black seal and then installs the plume.

Drawing below highlights plume dispersal kit.

LOW LEVEL FLUES

Low level flues installed in a corridor/alley - if the space is less than 3m, a plume kit must be considered. Where there is high risk of funnelling winds. Should the walls either side of the alley be high, again, a plume kit should be considered.

Low level flues installed in open area/garden - avoid facing the flue into the prevailing wind. The flue should face away from prevailing winds.

Please refer to site location sketches for outline of points above.

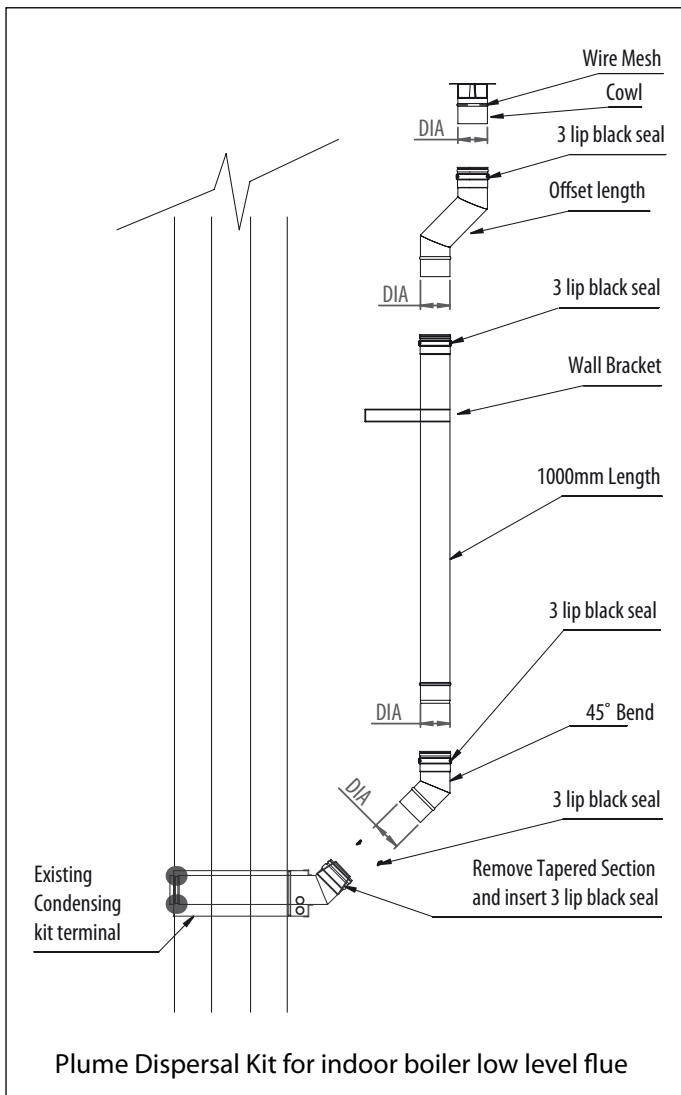

A boiler that fails to operate correctly may require a plume kit. This is because the flue gases are not able to disperse, causing the photocell to become dirty.

ITEMS TO BE CHECKED IN ALL CASES WHERE A BOILER IS OF CONCERN

There are four checks that must always be made where a photocell has stopped a burner:

- Ensure that the gasket door is sealed correctly to the boiler.
- Ensure that the burner collar is in place. If you see that the burner collar and surrounding area is getting black, this is highlighting that the boiler is experiencing down draught and requires resealing.
- A common fault can be that the installer has not placed the receiving nut for the burner on the boiler. If this nut is missing, then the burner sits incorrectly on the boiler.
- Ensure the flue is attached securely to the boiler, all seals are in place and telescopic flues are not extended beyond the maximum length.

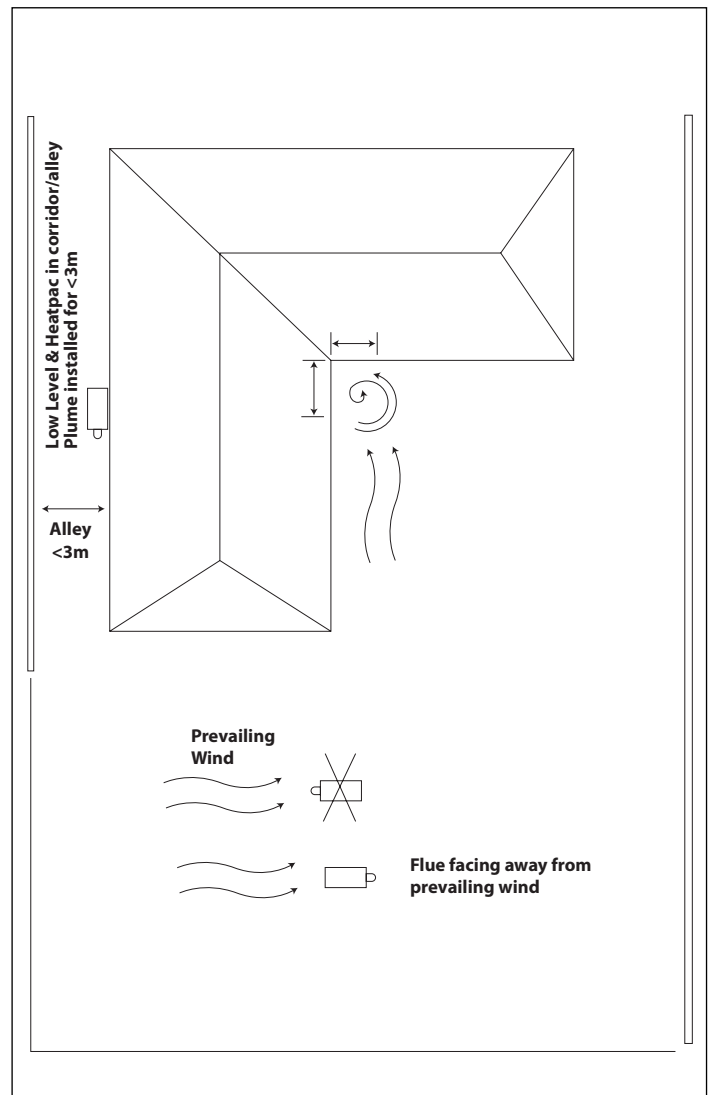

6 6.6 INSTALLATION - VENTILATION & COMBUSTION AIR REQUIREMENTS

INSTALLATION INSTRUCTIONS SUPPLIED WITH ALL FLUE KITS

CONDENSING BOILER CHIMNEY INSTALLATION

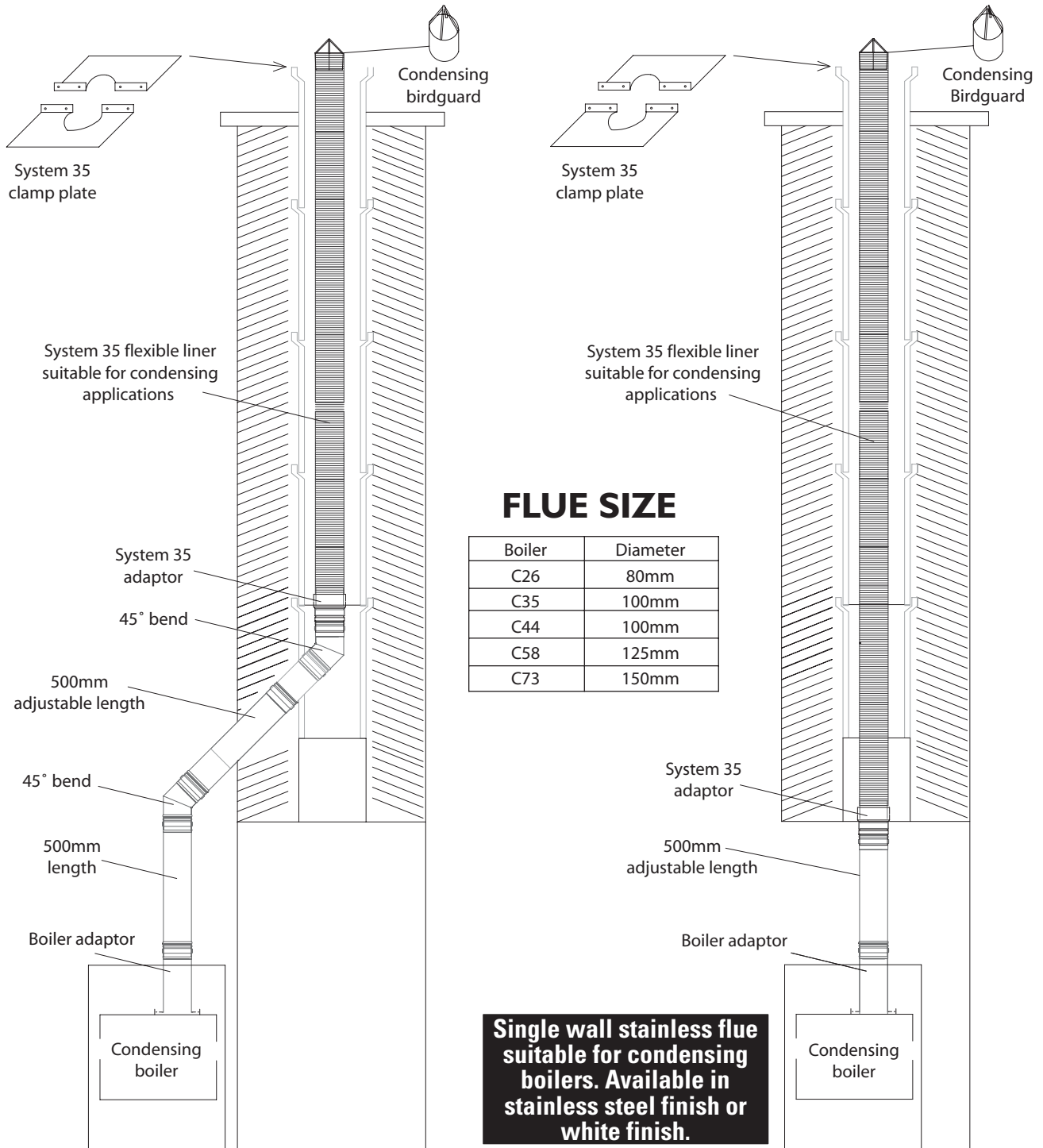

NOTE:

All brick chimney constructions must comply with current building regulations and BS5410 Part 1: 2014. Insulated factory made chimneys should comply with BS 4543.

6 6.7 INSTALLATION - FLUE ASSEMBLY

SLIMLINE SYSTEMPAC

Step 1 - remove top screws

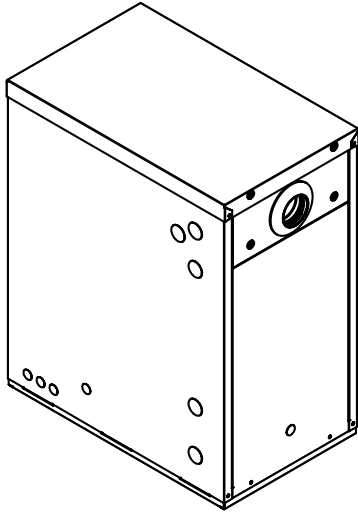

Step 2 - put elbow into flue outlet

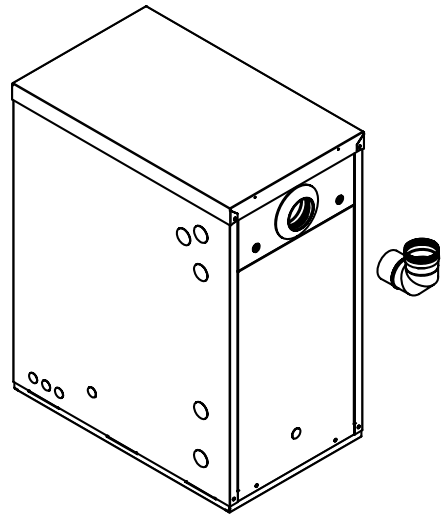

Step 3 - fix bracket to casing using supplied screws

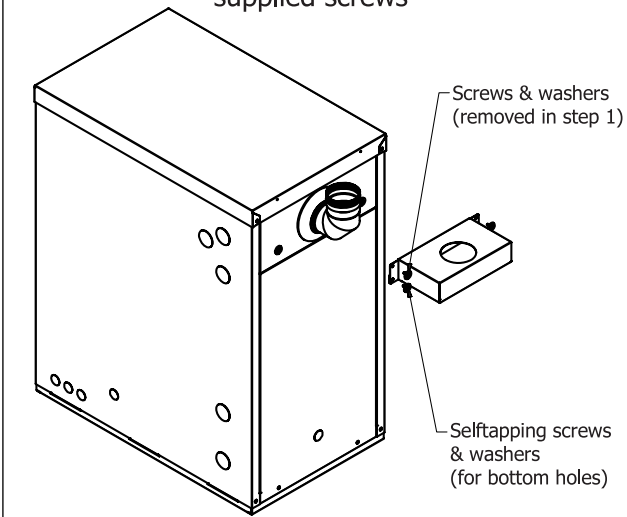

Step 4 - fix flue grommet on bracket

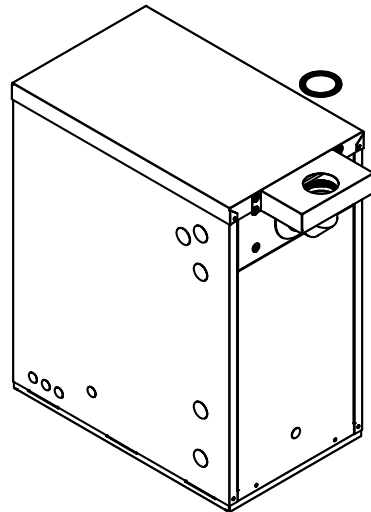

Step 5 - insert flue pipe and cowl

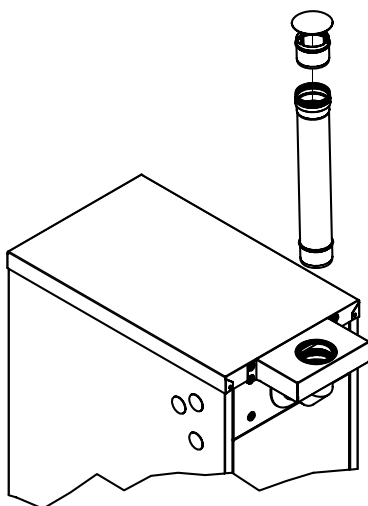

Final view

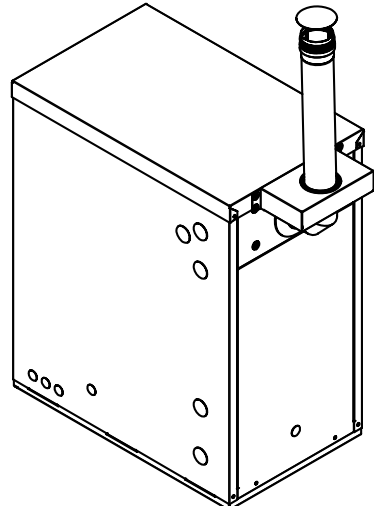

6 6.8.1 - INSTALLATION - WIRING - SYSTEM BOILER

ELECTRICAL SUPPLY

The boiler and controls require 230V 50Hz mains electric supply protected with a 5A fuse.

The warranty on this product will be rendered void if damaged by power from a stand by electricity supply i.e. (generator).

This appliance must be earthed.

A qualified electrician must carry out all electric wiring in accordance with current I.E.E regulations and any local regulations which may apply.

The mains electrical supply must be taken from a double pole isolating switch with a 5A fuse, positioned somewhere close to the boiler. Heat resisting cable must be used which can be routed into the boiler through the access provided on either side of the base. Ancillary controls may be provided for with terminal connections in the control panel.

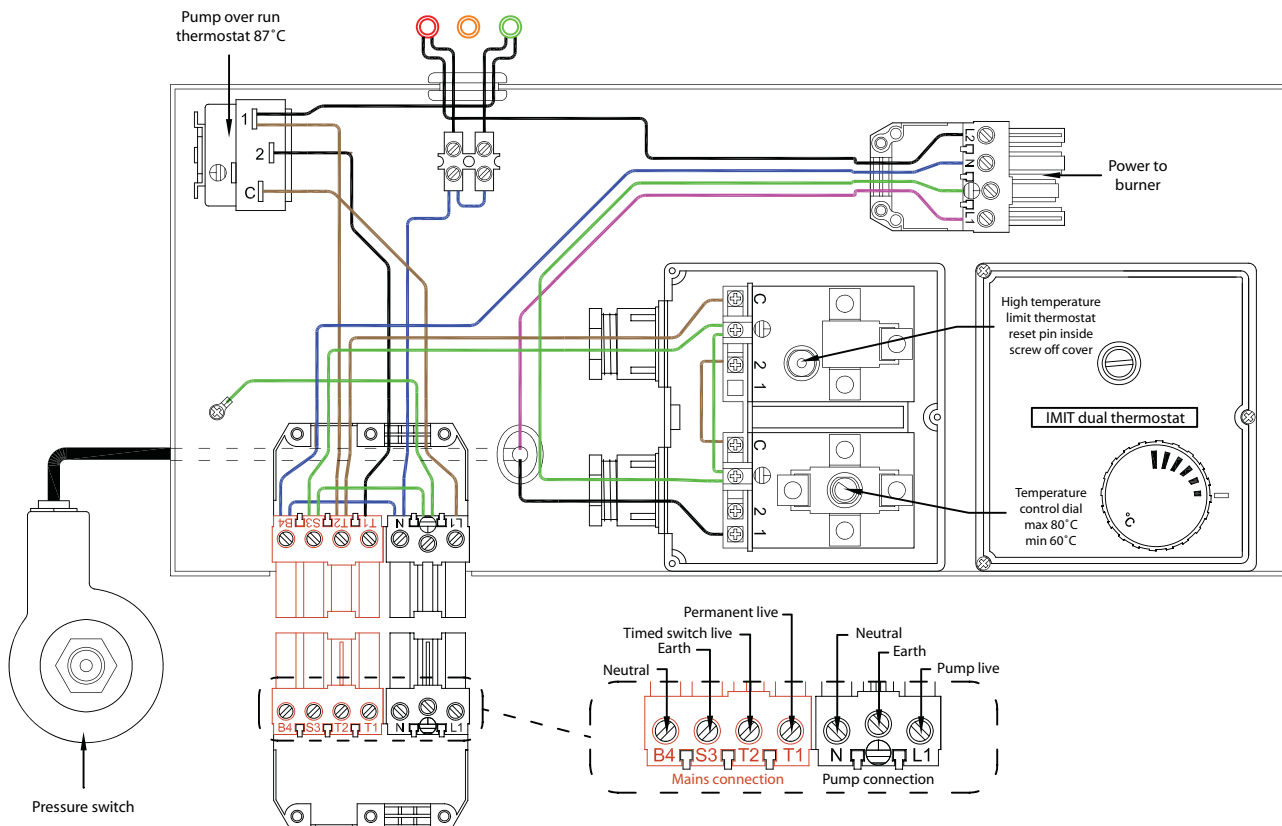

**Use heat resistant cable.
Protect supply with a 5A fuse.**

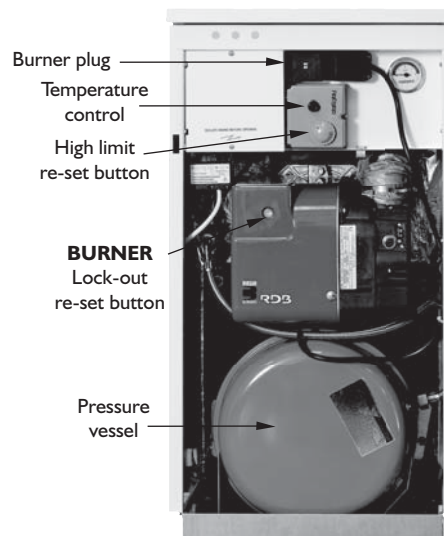

ELECTRICAL SUPPLY

The boiler and controls require 230V 50Hz mains electric supply protected with a 5A fuse.

The warranty on this product will be rendered void if damaged by power from a stand by electricity supply i.e. (generator).

This appliance must be earthed.

A qualified electrician must carry out all electric wiring in accordance with current I.E.E regulations and any local regulations which may apply.

The mains electrical supply must be taken from a double pole isolating switch with a 5A fuse, positioned somewhere close to the boiler. Heat resisting cable must be used which can be routed into the boiler through the access provided on either side of the base. Ancillary controls may be provided for with terminal connections in the control panel.

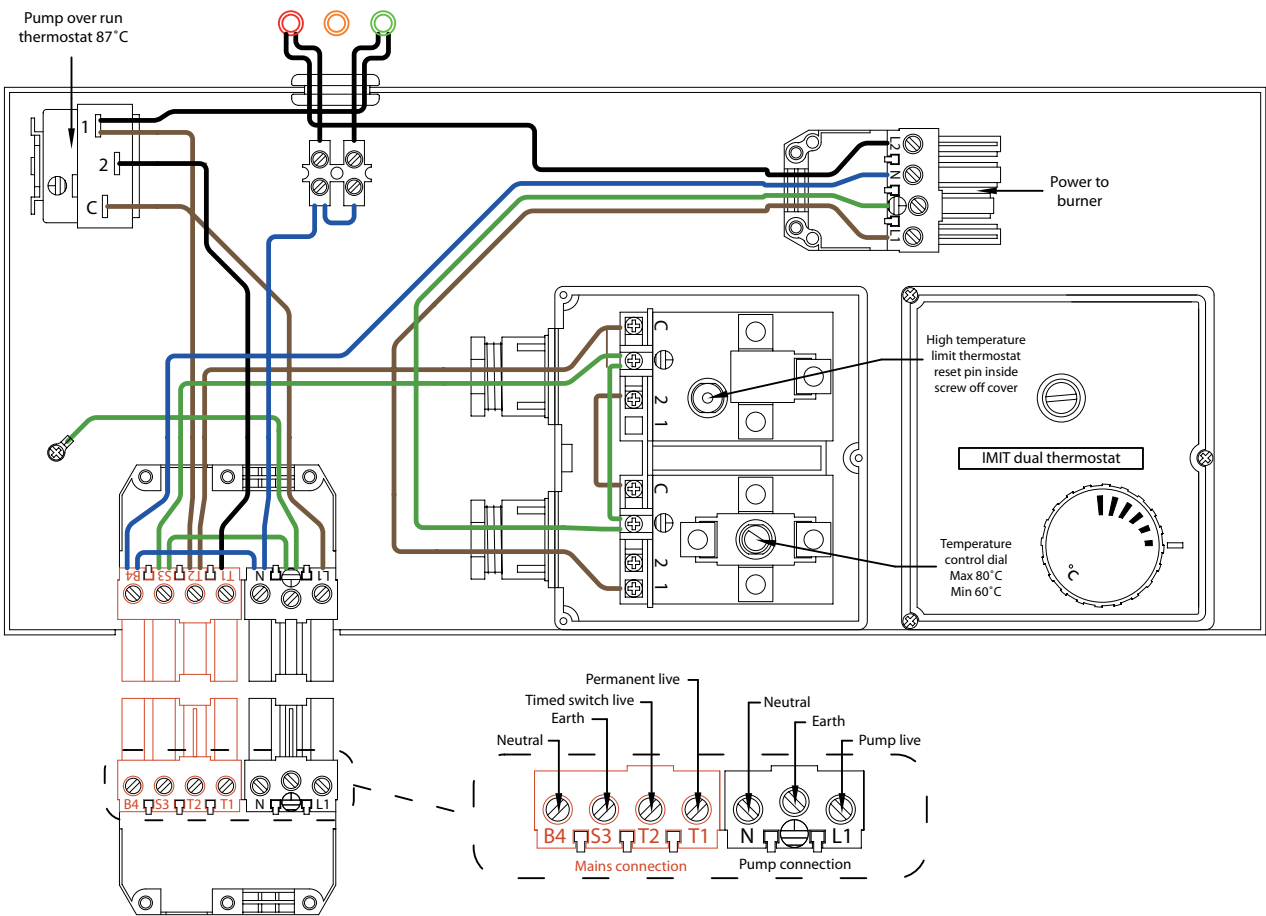

Use heat resistant cable. Protect supply with a 5A fuse.

6 6.8.3 INSTALLATION - WIRING - SLIMLINE SYSTEMPAC BOILER

ELECTRICAL SUPPLY

The boiler and controls require 230V 50Hz mains electric supply protected with a 5A fuse.

The warranty on this product will be rendered void if damaged by power from a stand by electricity supply i.e. (generator).

This appliance must be earthed.

A qualified electrician must carry out all electric wiring in accordance with current I.E.E regulations and any local regulations which may apply.

The mains electrical supply must be taken from a double pole isolating switch with a 5A fuse, positioned somewhere close to the boiler. Heat resisting cable must be used which can be routed into the boiler through the access provided on either side of the base. Ancillary controls may be provided for with terminal connections in the control panel.

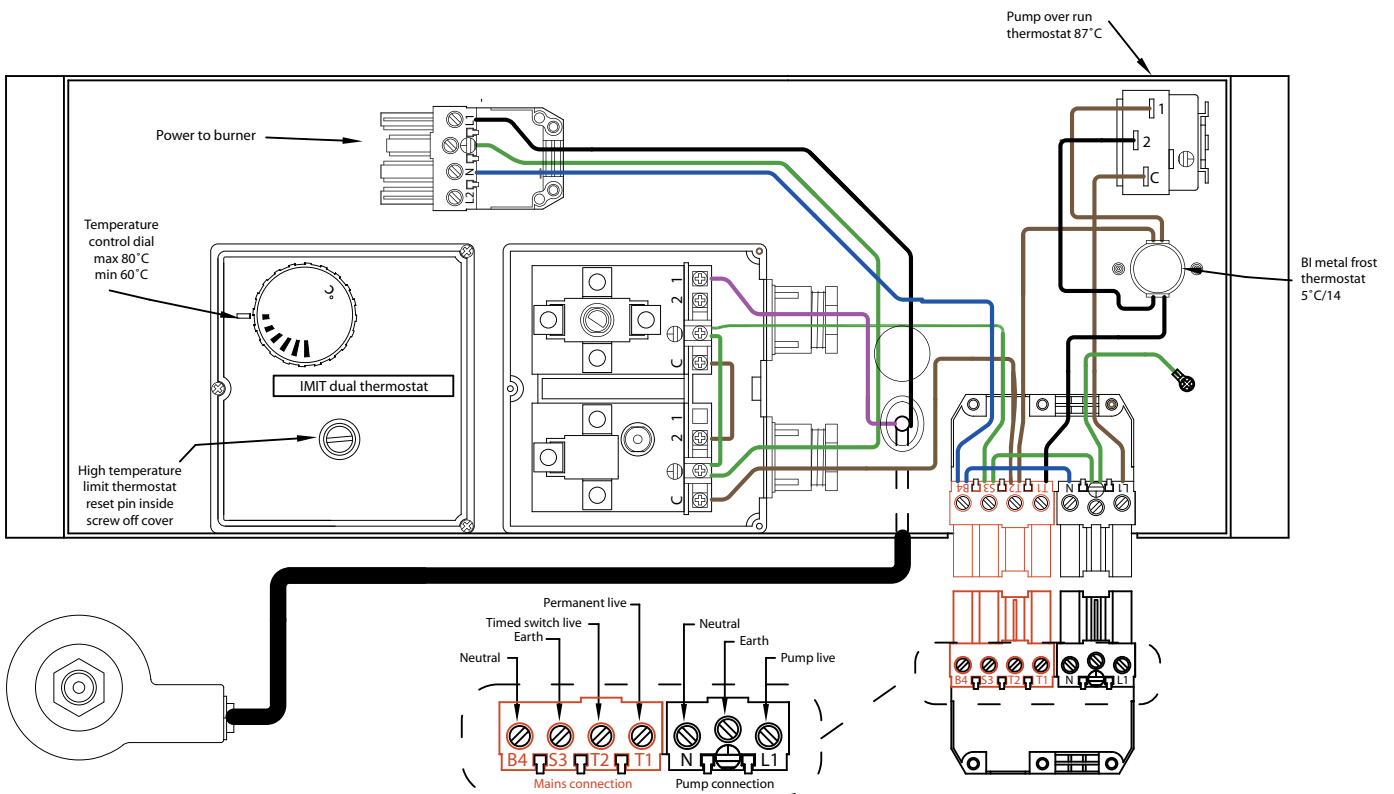

**Use heat resistant cable.
Protect supply with 5A fuse.**



7 pin plug
Power supply & pump

Burner plug

6 6.9 INSTALLATION - OIL SUPPLY

DIESEL STORAGE TANK SITING

Consult OFTEC manuals, AS1691 or Central Heating New Zealand Tank Guide.

It is unlikely that a fire will start at an diesel tank. However, the stored fuel must be protected from a fire or heat source that originates nearby. If the tank is installed closer than 1.8m to a building, the building wall should not have openings other than ventilation openings. A 30 minute fire rated barrier should be constructed between the hazard and the tank, which extends a minimum of 300mm higher and 300mm past each end of the tank. Note that a minimum separation distance should be maintained between a flue exit and fire barrier (see page 21 (flue clearances)).

Diesel storage tanks should not be sited within 1.8m of boiler flue outlets.

Do not allow household waste or hot ashes container in vicinity of oil storage tank or boiler flue outlet.

FLEXIBLE OIL PIPE(S)

A flexible burner diesel hose is supplied with the boiler which must be wholly contained within the appliance case.

The flexible diesel pipe supplied with the boiler is suitable for diesel only. The oil pipe must be upgraded to a bio-compatible Riello flexible oil pipe where a bio-fuel mixture is used.

Please note: A filter must not be fitted inside the boiler and all joints in the Diesel line must be Diesel tight. Soldered joints are not permissible. Before connecting to the boiler, always flush the complete Diesel supply line and ensure that Diesel supply is completely clean and free of any dirt or foreign matter.

SINGLE PIPE SYSTEM

Where installation is such that the bottom of the tank is located above the Diesel burner, a single pipe system may be used. The Diesel burner should then be set for single pipe operation (see also manufacturer's Diesel burner manual).

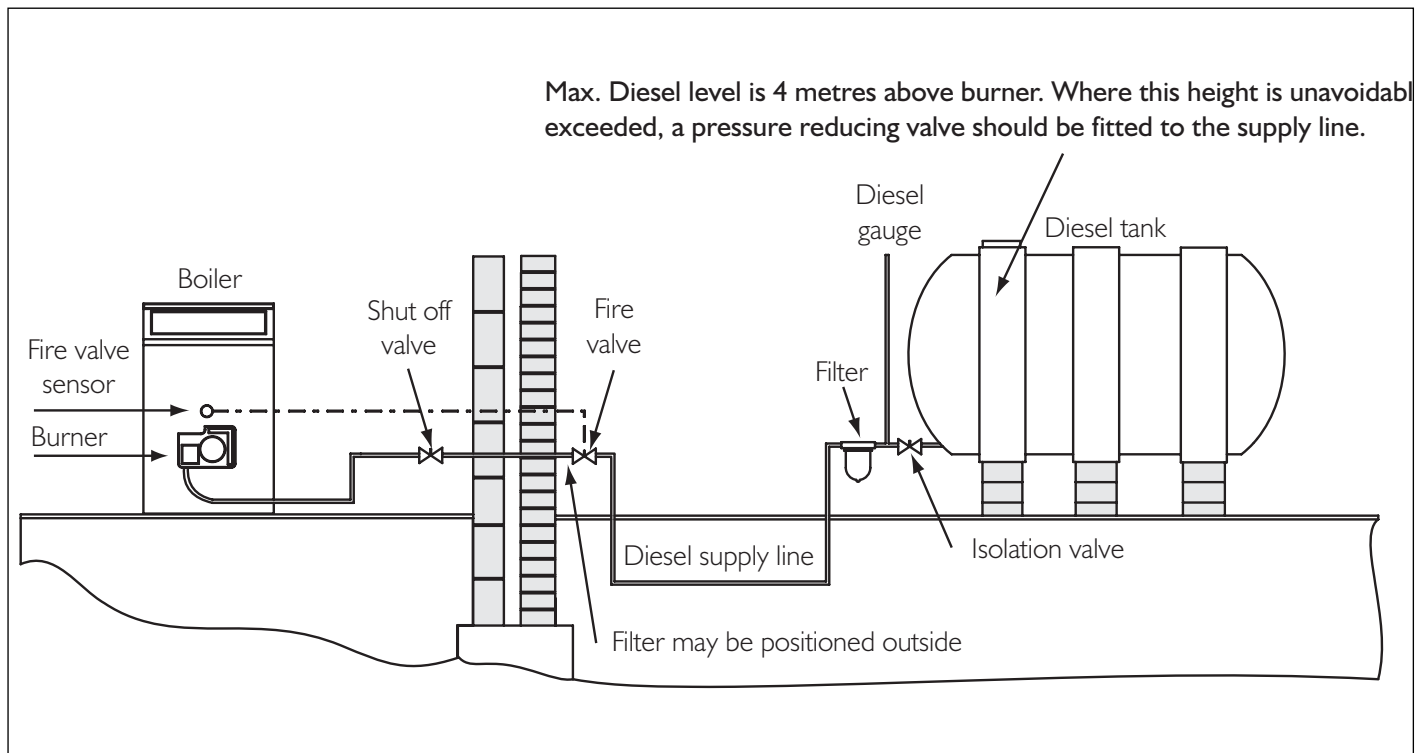

6 6.9 INSTALLATION - OIL SUPPLY

TWO PIPE SYSTEMS

Where installation is such that the bottom of the tank is located below the Diesel burner pump, a two pipe system is required. Ensure that valves and filters are not fitted in the return line as this must be unobstructed at all times.

The Diesel burner pump should be set for two pipe operation as detailed in accompanying Diesel burner manufacturer's manual, refer also to burner section of this manual.

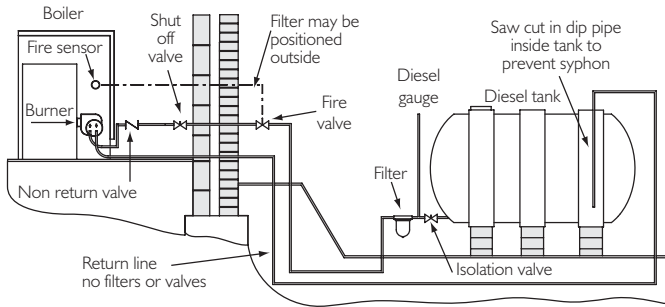

DEAERATOR SINGLE PIPE SYSTEMS

Deaerators should not vent in internal spaces
(see OFTEC book 3)

Where installations normally require a two pipe system but have long or impractical return line runs, a deaerator can be used which removes air from a single - pipe - lift Diesel feed. Higher lift heights can be achieved than are possible with conventional two pipe systems.

The Diesel burner pump should be set for two pipe operation.

INDIVIDUAL DEAERATOR INSTRUCTIONS MUST BE IMPLICITLY FOLLOWED.

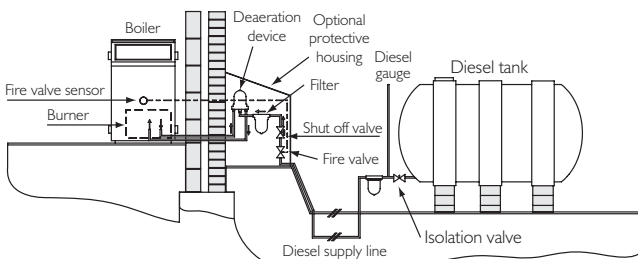

Schematic Drawing

Single pipe Diesel supply with deaeration device (eg. deaerator).
Bottom of diesel tank below or level with burner.
(Adapted from OFTEC drawing)

The recommended minimum filtration rate is 70 μm .

FIRE VALVES

A fire valve is an essential part of the Diesel supply system. It should be capable of cutting off the flow of Diesel outside the building in the event of a fire starting up within the boiler. The valve should be located just outside the building at the point where the Diesel supply line enters. It must be activated by a remote sensor located over the burner, but in a position clear of any direct radiation or excessive heat.

IMPORTANT:

Fire Valves should comply with OFTEC Standards OFS E101. Fitting of fire valves should comply with BS 5410 Part 1:2014 and OFTEC book 3.

MAGNETIC FILTRATION

Effective permanent magnetic filtration of central heating systems.

It is recommended at the time of installation of this boiler, to install a permanent effective magnetic filter on the return pipework after the last radiator on the central heating system.

This will maintain maximum operational efficiency and protect the boiler from the damaging, long-term effects of "magnetite" (black iron sludge). It is essential that the filter is sized similar to the return pipework e.g. 22mm (3/4") or 28mm (1"). In all circumstances, an effective magnetic filter must be installed in accordance with the manufacturer's instructions.

COMMISSIONING

- ◆ It is the responsibility of the installer/end user to ensure that the boiler is properly commissioned when first used.
- ◆ The boiler should be commissioned by a competent, qualified engineer, preferably familiar with Firebird products.
- ◆ The commissioning card should be completed and posted to Central Heating New Zealand within 28 days of installation and a copy should be retained by the commissioning engineer.
- ◆ The system should be checked thoroughly.

PROCEDURES

DIESEL TANK

The installation of the Diesel tank and supply line should comply with all the instructions shown earlier in this manual. Consult OFTEC Book 3.

If a single supply line is used, ensure that the bottom of the tank is above the burner. A suction line system via a deaerator should be used where the level of the diesel in the tank may fall below the level of the oil burner pump.

Check and ensure correct grade fuel oil has been supplied.

OIL SYSTEM

A two single pipe system may also be used in low-level tank installations (see previous page). Please flush out the diesel pipe by drawing off some diesel before connecting the fuel pipe to the burner - otherwise there is a danger of grit and dirt being forced into the burner pump, resulting in pump blockage, damage and "lock-out".

CHECKLIST FOR INSTALLING AND COMMISSIONING A FIREBIRD BOILER

Pre-installation check:

- ◆ Is the following documentation included with the boiler, Installation Manual, Burner Book?
- ◆ Is the base on which the boiler is to be installed solid?
- ◆ Allow sufficient room for future servicing of the boiler.

Where does the flue terminate:

- ◆ Make sure there is no window, door or fence within 1 metre of the flue-terminal.
- ◆ If the flue terminates in a corner or into an alleyway, re-circulation of the combustion gases in the air intake could occur. A plume dispersal may be required or an alternative flue arrangement might be available. Contact the Central Heating New Zealand technical department.
- ◆ The appropriate class 1 flue must be used with a conventional flue installation. Contact Central Heating New Zealand if unsure.

Power supply:

- ◆ Is a timed and permanent power supply available, via a fused spur with a 5amp fuse.

Oil supply:

- ◆ The burner is set for Diesel 35 Second Gas Oil
- ◆ Check that there is a good quality filter on the line with an isolating valve.
- ◆ There should be a remote sensing fire valve.
- ◆ If a deaerator is required, fit the bypass screw in the diesel pump. Check that the second flexible diesel line is approved by the manufacturer.
- ◆ Verify that the diesel tank has been installed correctly as per building standards.

7 COMMISSIONING

Boiler check:

- ◆ All baffles should be installed correctly.
- ◆ Check that the condensate trap is fitted securely, primed with water and piped out into a suitable drain. It is easier to check the trap when the boiler door is removed.
- ◆ The boiler door should be refitted, complete with graphite seal and then tightened.

Flue check:

- ◆ The flue must be fitted correctly, with a fall back to the boiler. Note: internal fall of 2.5° within the flue.
- ◆ For concentric balanced flue:
 - the cone supplied should be inserted in to the end of the flue;
 - the wall plate should be fitted with an opening for air under the flue;
 - check that the flue guard is fitted.
- ◆ When installing a Slimline Heatpac, the 90° bend should be fitted pointing up.

Burner set-up:

- ◆ Check that the nozzle is the right size for the type of boiler and for the system heat demand.
- ◆ Set the air to what is required for the nozzle size +.5 on the dial - example: the factory setting for a Firebird C26 has a Danfoss .65 80° ES nozzle with a pump pressure of 9 bar and air at 2.5. Set the air to 3 for the first start up. The final air setting to suit the boiler set up will be determined by using a flue gas analyser.
- ◆ Check all connections for possible leaks.
- ◆ Turn on the oil supply and switch on power to the boiler.
- ◆ Set the thermostat at minimum.
- ◆ Use a smoke gun to check clean combustion.

Flue gas analysis and fine tuning of burner:

- ◆ Ensure flue gas is over 50°C when setting CO₂.
- ◆ Allow the boiler to run for a period of time before fine tuning to the Firebird settings.
- ◆ This fine tuning should be done with the boiler in the condition it is going to be operating at, that is, if a balanced flue is installed, the air hose is fixed on the burner. In the case of a Slimline Heatpac, ensure that the door is closed for a period of time before setting the analyser on the system.
Note: When fine tuning the burner with the flue gas analyser, adjustments in both the air and pump pressure may be required to achieve the desired CO₂ %.
- ◆ Print off a copy of the flue analysis and attach to the commissioning card.
- ◆ Make sure the flue gas analysis plug is replaced correctly into the flue when finished the flue analysis.
- ◆ Check the correct operation of the thermostat on the boiler.

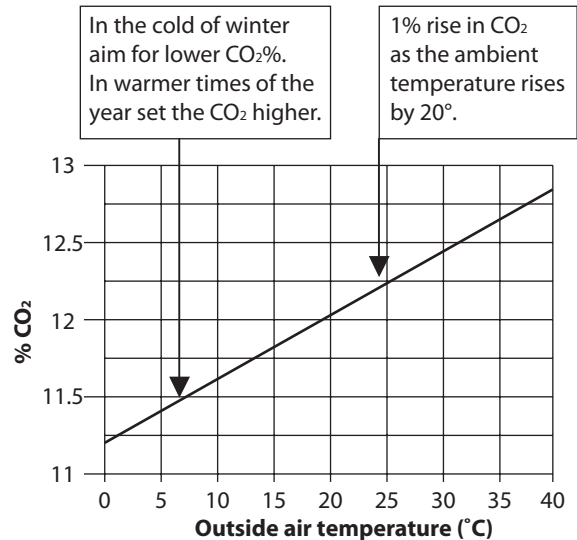

HANDING OVER

The end user should receive:

- A clear and concise demonstration of the boiler operation and any system controls.
- This manual, the burner manufacturer's manual and any other instructions.
- OFTEC forms CD10 and CD11.

The end user should be advised to:

- Service the boiler annually and to ensure that the service records are completed.
- Read the terms and conditions of warranty.
- Keep all boiler documentation in a safe place.

A commissioning record should be completed and a copy retained by the Engineer.

Annual servicing must be carried out by a competent, qualified engineer, preferably familiar with Firebird products.

Do not commence service until both the electrical and diesel supply to the boiler have been safely isolated.

THE DIESEL TANK

Check for diesel leaks. Draw off any accumulated water and sludge from the tank by opening the drain valve. Turn off the diesel supply and remove the filter bowl, then wash the element clean with diesel. Fit a new element if required.

THE BOILER

Remove combustion access door for access to baffles and to clean heat exchanger.

Cleaning a Firebird condensing boiler:

1. Remove all baffles, including the tubular baffles in the condensing section and clean them.
2. Remove the condense trap and clean it, place a tray under the connection for the trap. Vacuum out any loose debris from the chamber.
3. Clean the inside of the boiler with a vacuum cleaner.
4. Refit all the baffles and the condensate trap securely.
5. System pressure should not exceed 2 bar at full operating temperature. The expansion vessel should be checked during the annual service to ensure that it is operating correctly.

Check insulation sealing and the silver foil lining in combustion access door - replace if necessary. Check graphite seal and replace if necessary. When refitting this door be careful not to damage the foil and insulation by over tightening.

Check that the condensate trap is secure in position, clean and free of combustion debris. Ensure that the condensate drain is free and not blocked.

Expansion vessel pre-charge pressure should be checked annually.

THE BURNER

Check diesel nozzle size and replace (see burner section for details).

Ensure correct specification replacement nozzle is used.

1. Check all diesel filters and replace as necessary.
2. Remove burner and clean blast tube and ensure that airways are clear.
3. Ensure electrodes are clean, dry, not broken and are set as per burner specifications.
4. Clean fan and photocell.
5. **Once again check flexible diesel lines and connections for damage or leaks, replace as necessary. Replace flexible diesel lines every 2 years.**

Combustion Check

1. Carry out a combustion analysis.
2. Follow the steps as set out in the burner set-up section.
3. Check safety operation, pull out the photo cell, cover and make sure the burner locks out.
4. Check the thermostat operation.
5. Allow the boiler to operate for at least two full "on/off" cycles.

Ensure service record is completed.

9 9.1 BURNER - SETTINGS

The burner nozzle, pump pressure and air setting may have to be changed from the factory setting to suite site conditions.

Riello RDB 2.2 Range Burner Settings

Variations in nozzle throughput, flue type & draught, oil viscosity etc. may give results differing from these laboratory performance figures. These settings were carried out using a conventional flue.

DIESEL SETTINGS FOR FIREBIRD BOILER RANGE USING RDB 2.2 & 4.2 BURNERS

Model	Burner	Output kW BTU	Blast Tube	Nozzle Size - Angle - Type			Pump Pressure	Air Shutter	Comb Head	Air Box	Avg. Fg. °C	CO ₂	Smoke Bacharach	Restrictor Disc	Deflector Plate
C 26	RDB 2.2R	22 75K	T3	0.50	80°	S	12 bar	3.2	-	1	70	11.5%	0-1	-	STD
		23 80K	T3	0.50	80°	S	13 bar	3.5	-	1	70	11.5%	0-1	-	STD
		26 90K	T3	0.55	80°	S	12 bar	4.5	-	1	75	11.5%	0-1	-	STD
C 35	RDB 2.2R	26 90K	T5	0.55	80°	S	12 bar	2.2	-	2	85	11.5%	0-1	-	STD
		31 110K	T5	0.65	80°	S	12.5 bar	2.8	-	2	90	11.5%	0-1	-	STD
		35 120K	T5	0.65	80°	S	13.5 bar	4.0	-	2	95	11.5%	0-1	-	STD
C 44	RDB 2.2R	40 135K	T5	0.85	80°	S	12.5 bar	4.5	-	2	60	11.5%	0-1	-	STD
		42 145K	T5	0.85	80°	S	14.0 bar	6.0	-	2	65	11.5%	0-1	-	STD
		44 150K	T5	1.00	60°	S	12.0 bar	6.5	-	2	70	11.5%	0-1	-	STD
C 58	RDB 4.2R	54 150K	Adj.	1.10	60°	S	12 bar	4.5	1.0	-	70	11.5%	0-1	-	-
		56 174K	Adj.	1.10	60°	S	14 bar	6.5	1.5	-	75	11.5%	0-1	-	-
		58 198K	Adj.	1.25	60°	S	12 bar	5.5	2.0	-	80	11.5%	0-1	-	-
C 73	RDB 4.2R	68 232K	Adj.	1.35	60°	S	13 bar	5.8	3.0	-	70	11.5%	0-1	-	C100
		73 249K	Adj.	1.50	60°	S	12.0 bar	7.5	5.0	-	80	11.5%	0-1	-	C100
C 100	RDB 4.2R	90 272K	Adj.	1.75	60°	S	14 bar	7.5	5.0	-	80	11.5%	0-1	-	C100
		100 340K	Adj.	2.00	60°	S	12.5 bar	8.0	5.0	-	80	11.5%	0-1	-	C100

The above settings were carried out on a Firebird condensing boiler with 2 metres of vertical balanced flue. The ambient air was averaging around 20°C. Allowances should also be made for the viscosity of the oil and the tolerance of the nozzles. These settings are a guide and should only be used as such. A flue gas analyser must be used when fine tuning a burner to a boiler. When using this chart on a burner fitted to a standard efficient boiler air setting may vary.

Steps in commissioning a Firebird boiler burner:

1. Check nozzle to required output.
2. Is the correct burner head fitted to the burner for the required output?
3. Set air damper using the guide above to the desired output.
4. Check the pump pressure.
5. Set boiler thermostat to minimum and allow boiler to heat up before carrying out a flue gas analysis.
6. Check flue gasses with a smoke gun before using flue gas analyser.
7. Proceed with flue gas analysis, adjust air damper to get desired CO₂%.
8. Print a record of analysis result.

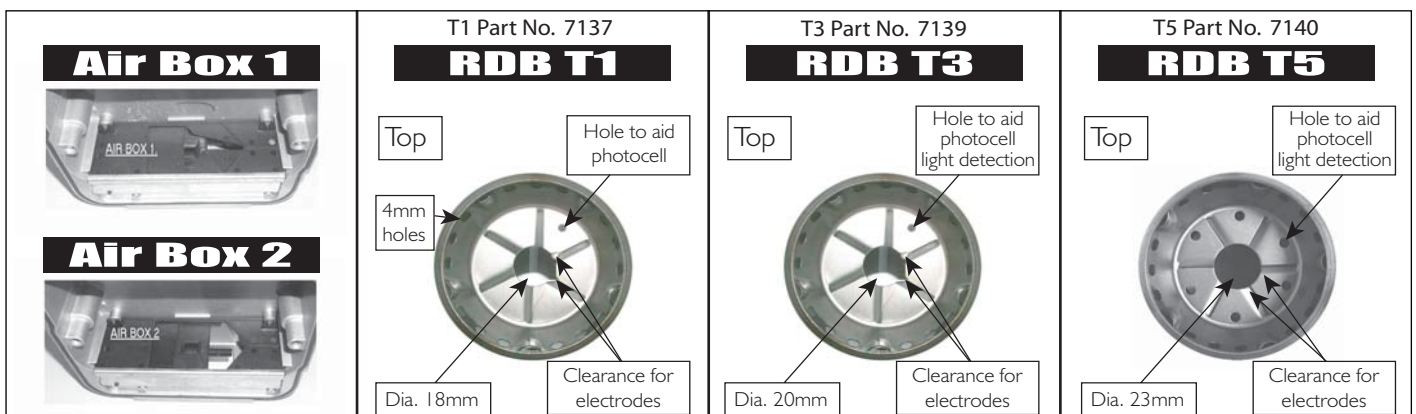

9 9.2 BURNER - G10 BLAST TUBE

APPLIES TO C58-C100

Boiler	Burner	Nozzle	Pump	Air	Blast Tube	Head	Air Box	CO ₂	
	RDB4.2 200/250K & C73	1.25 60 S	12.0 bar	6	G10	2	2	11.5%	0

Make sure the door of the Slimline Systempac is in place when setting the CO₂. Take the flue analysis from the flue terminal.

G10 BLAST TUBE



The diffuser moves in and out when the head setting is increased or decreased.

The diffuser moves back into the head when the head setting is decreased, pushing the air through the centre of the diffuser.

The diffuser moves forward when the head setting is increased, pushing the air around the outside of the diffuser.

To adjust the head setting, rotate bar A clockwise to increase and anti-clockwise to decrease until the numbers line up with the edge of the blast tube.

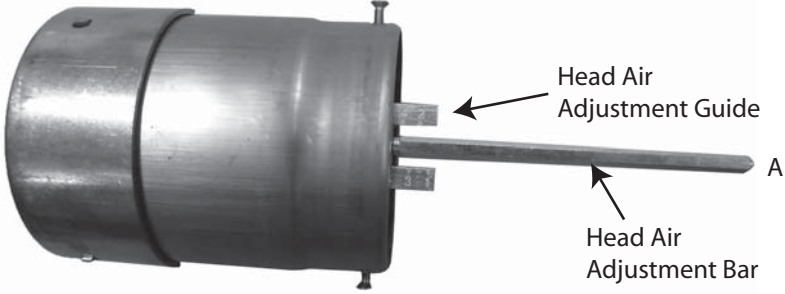

Head Air Adjustment Guide

Head Air Adjustment Bar A

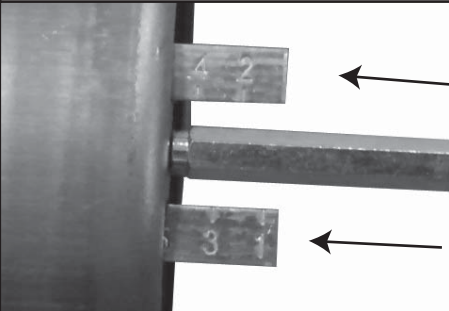

Adjust the no. 2 head setting into the edge of the blast tube.

This is currently set at 5.

These settings are a guide for the commissioning engineer and may give varying results in different site locations. Variations in nozzle throughput, flue type, ambient air temperature, oil viscosity, altitude etc. may give results differing from these laboratory performance figures. These settings were carried out using a conventional flue.

The fuel option on the flue gas analyser should be set a Light Diesel Oil.

Burner Description

One stage kerosene burner.

The intake air temperature must not be over 70 °C.
 Burner with CE marking in conformity with EEC directives:
 EMC 89/336/CEE and Efficiency 92/42/EEC.
 CE Certification No.: **0036 0316/01** as 92/42/CEE.

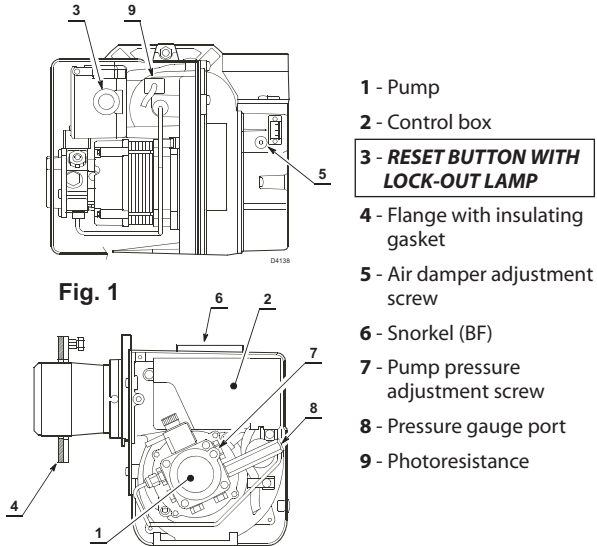

- 1 - Pump
- 2 - Control box
- 3 - RESET BUTTON WITH LOCK-OUT LAMP**
- 4 - Flange with insulating gasket
- 5 - Air damper adjustment screw
- 6 - Snorkel (BF)
- 7 - Pump pressure adjustment screw
- 8 - Pressure gauge port
- 9 - Photoresistance

1.1 BURNER EQUIPMENT

- Flange with insulating gasket N.º 1
- Screw and nuts for flange N.º 1
- Hexagonal key N.º 1
- Plastic air cover N.º 1
- Screws for flange to be fixed to boiler . . N.º 4
- Flexible oil pipes with nipples N.º 2
- By-pass screw for 2 pipe system N.º 1

**ELECTRODE SETTING
 Riello RDB 2.2**

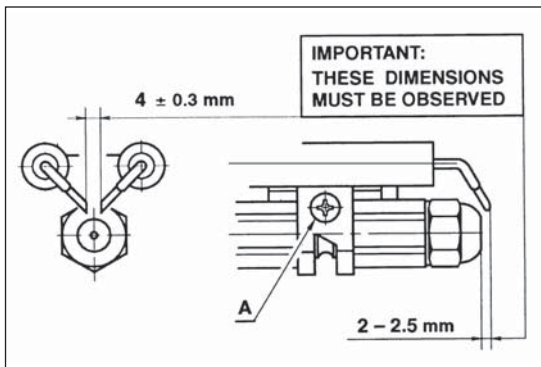

ATTENTION

Before assembling or removing the nozzle loosen screw (A) and move electrodes forward.

HYDRAULIC SYSTEM

WARNING

- **SINGLE PIPE**
 The pump is designed to allow working with one pipe.
- **TWO PIPE**
 In order to obtain two pipe working it is necessary to unscrew the return plug (2), screw in the by-pass screw (3) and then screw in return oil line (2). (See fig. 4).
 In the two pipe systems, before starting the burner make sure that the return pipe-line is not clogged. An excessive back pressure would cause the damage of the pump seal.

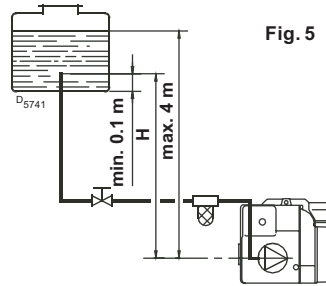

H meters	L meters	
	I. D. 8 mm	I. D. 10 mm
0.5	10	20
1	20	40
1.5	40	80
2	60	100

- 1 - Suction pipe
- 2 - Return line
- 3 - By-pass screw (* is supplied loose in burner pack)
- 4 - Pressure gauge connection & Bleed screw
- 5 - Pressure adjuster
- 6 - Vacuum gauge connection
- 7 - Valve
- 8 - Auxiliary pressure test point

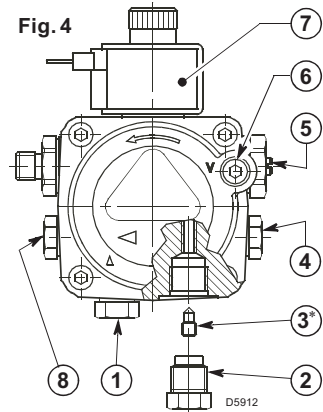

H meters	L meters	
	I. D. 8 mm	I. D. 10 mm
0	35	100
0.5	30	100
1	25	100
1.5	20	90
2	15	70
3	8	30
3.5	6	20

PRIMING PUMP:

On the system in fig. 5 it is sufficient to loosen the suction gauge connection (6, fig. 4) and wait until oil flows out.
 On the systems in fig. 6 and 7 start the burner and wait for the priming. Should lock-out occur prior to the arrival of the fuel, await at least 20 seconds before repeating the operation. The pump suction should not exceed a maximum of 0,4 bar (30 cm Hg). Beyond this limit gas is released from the oil. Oil pipes must be completely tight.
 In the vacuum systems (fig. 7) the return line should terminate within the oil tank at the same level as the suction line. In this case a non-return valve is not required. Should however the return line arrive over the fuel level, a non-return valve is required. This solution however is less safe than previous one, due to the possibility of leakage of the valve.

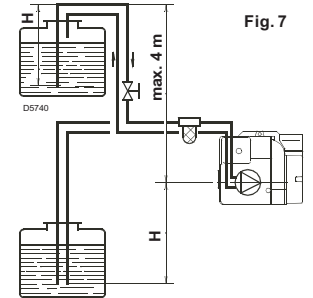
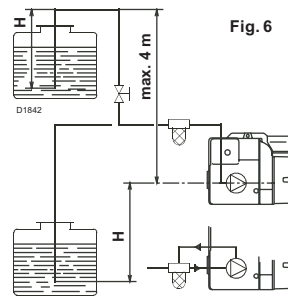

H = difference of level L = Max. length of the suction line
 I.D. = Internal diameter of the oil pipes

For Full details on suction line systems please refer to OFTEC Technical Information Sheet T1/139 (T32)

Troubleshooting Guide for Riello RDB Burner Fault Finding Logic For Control Box Type 5352 SE/LD RDB Series Oil Burners

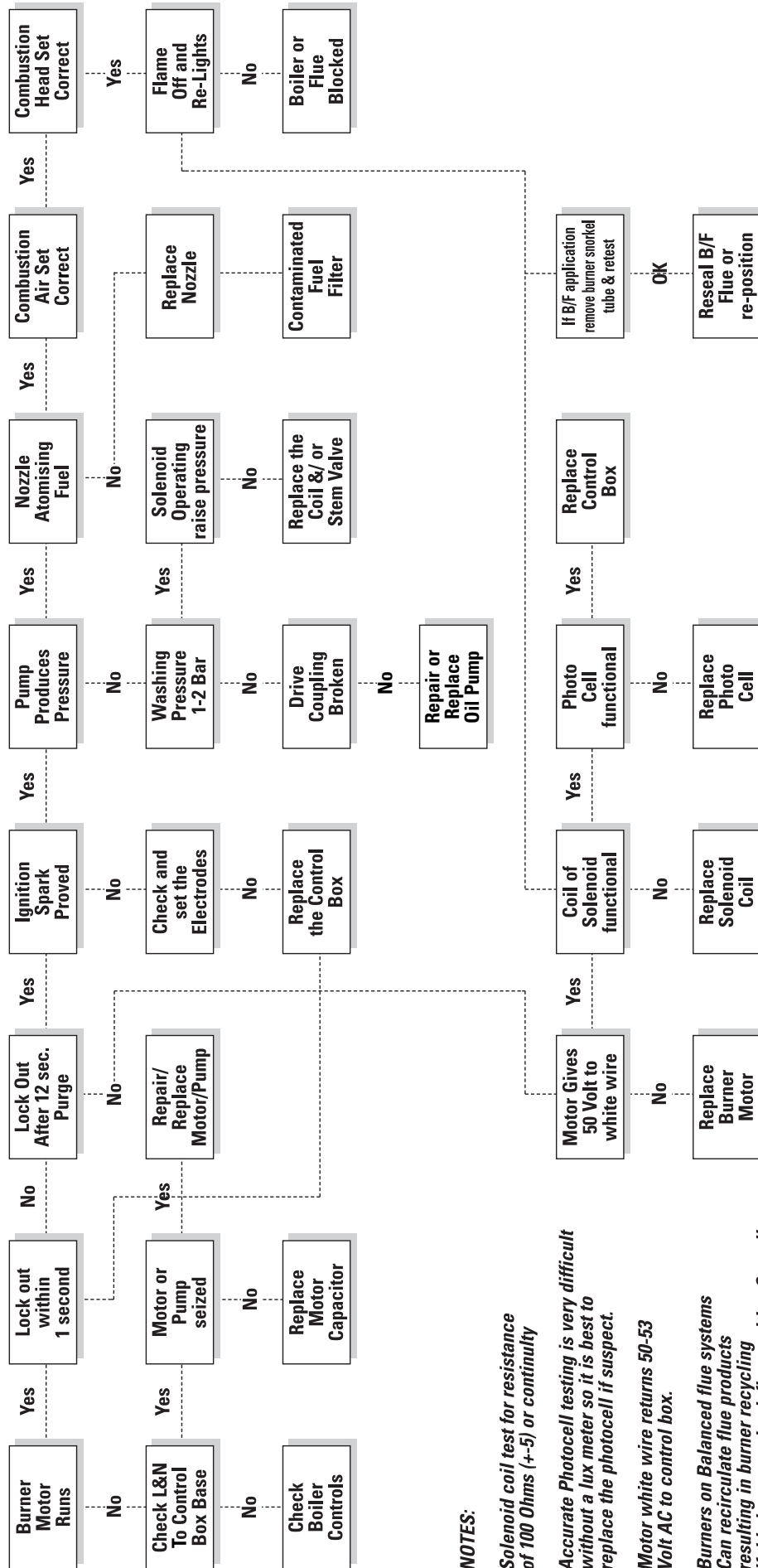

NOTES:

- Solenoid coil test for resistance of 100 Ohms (+-5) or continuity
- Accurate Photocell testing is very difficult without a lux meter so it is best to replace the photocell if suspect.
- Motor white wire returns 50-53 Volt AC to control box.
- Burners on Balanced flue systems Can recirculate flue products resulting in burner recycling if this happens check flue position & sealing.

10 10.1 - PARTS & BAFFLES - SYSTEM BOILER

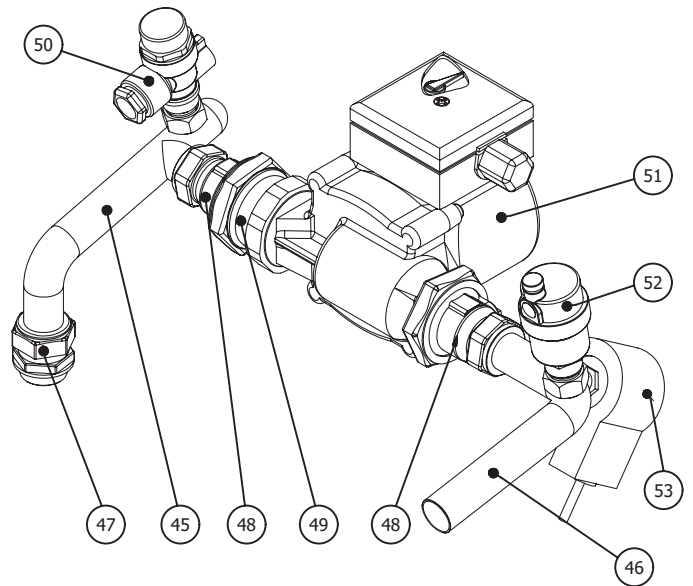
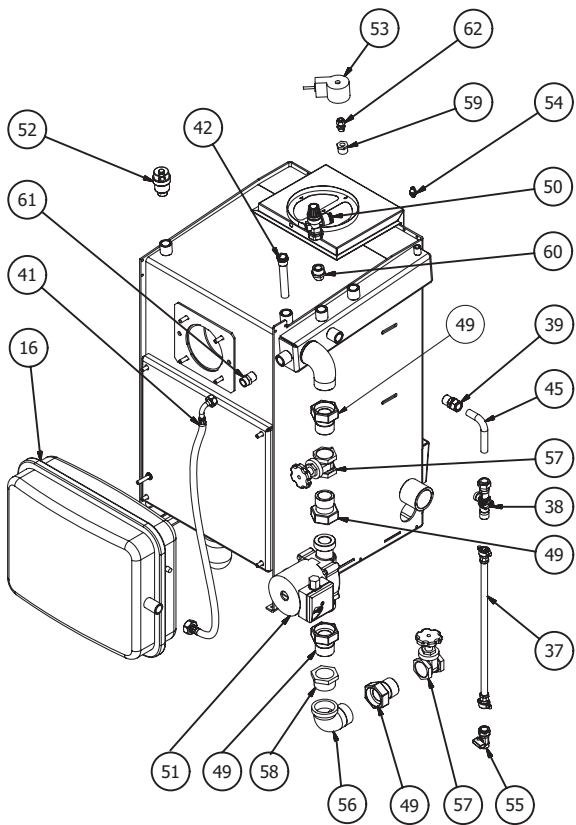
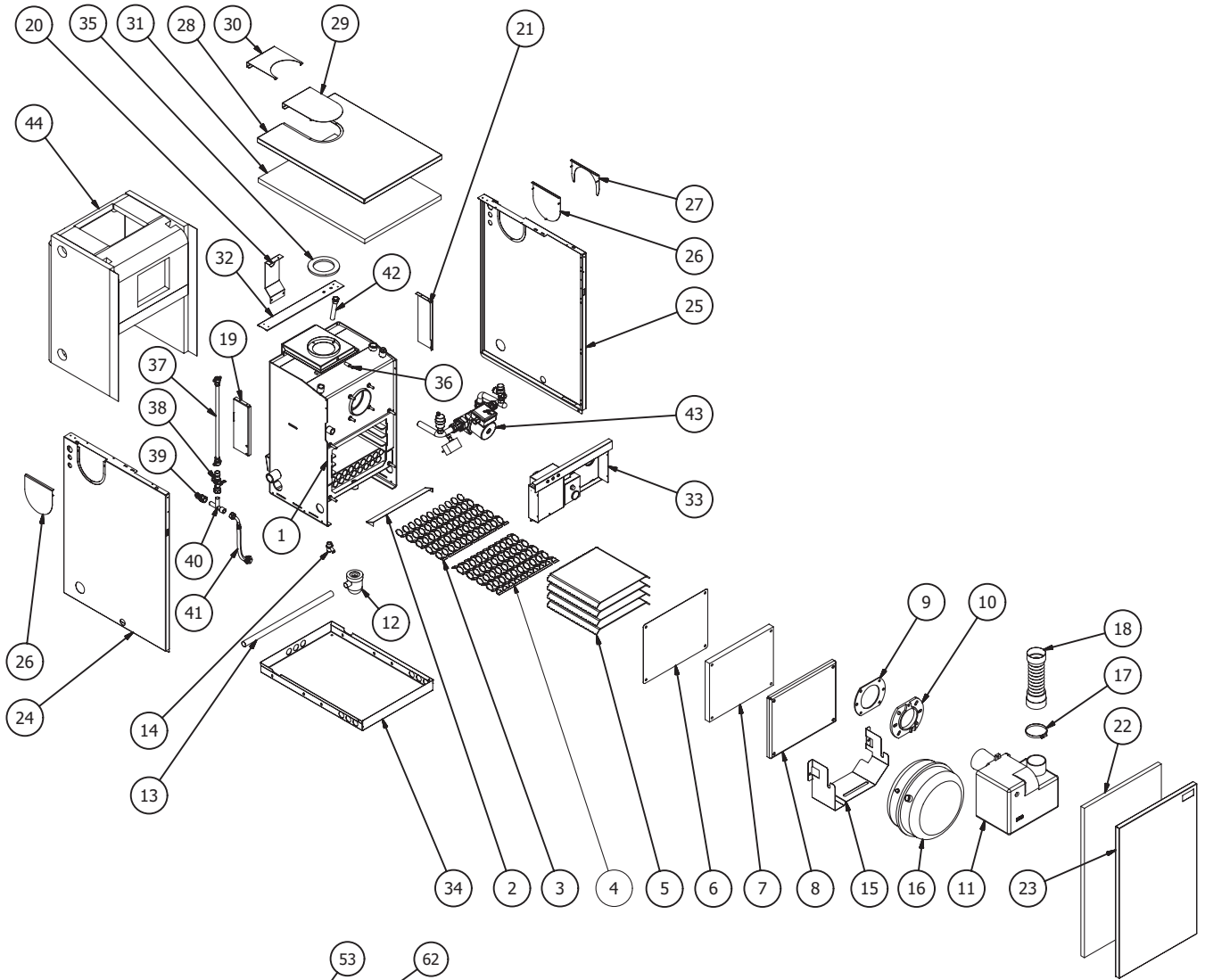

10 10.1 - PARTS & BAFFLES - SYSTEM BOILER

No.	Description	C20	C26	C35	C44
1	Boiler Shell	312133	312133	312133	311783
2	Heat Deflector	210904	210904	210904	211643
3	Tube Baffle 1 Way	110908 (5 off)	110908 (5 off)	110908 (5 off)	111502 (8 off)
4	Tube Baffle 4 Way	110907 (4 off)	110907 (4 off)	110907 (4 off)	111503 (6 off)
5	Smoke Baffle	212022 (4 off)	212028 (4 off)	212122 (4 off)	211651 (8 off)
6	Graphite Door Seal	111314	111314	111314	111646
7	Door Gasket	110918	110918	110918	111645
8	Boiler Door	210910	210910	210910	211644
9	Burner Insulation Gasket	ZE2567398	ZE2567398	ZE2567398	ZE2567398
10	Burner Flange	ZE2567398	ZE2567398	ZE2567398	ZE2567398
11	Burner	410205	410206	410207	410209
12	Condensate Trap	112184	112184	112184	112184
13	Condensate Hose	111537	111537	111537	111537
14	Drain Cock	111329	111329	111329	111329
15	Pressure Vessel Bracket	210962	210962	210962	n/a
16	Pressure Vessel	110658	110658	110658	110755
17	Jubilee Clip	110481	110481	110481	110841
18	Air Hose	111902	111902	111902	111902
19	Casing Left Bracket	212321	212321	212321	211805A
20	Casing Back Bracket	210916	201916	210916	211770
21	Casing Right Bracket	210915B	210915B	210915B	211797
22	Casing Front Insulation	110937	110937	110937	111788
23	Casing Front	111376	111376	111376	111787
24	Casing Left Panel	111374A	111374A	111374A	111786
25	Casing Right Panel	111374B	111374B	111374B	111792
26	Casing Side Blank 1	113031	113031	113031	n/a
27	Casing Side Blank 2	113032	113032	113032	n/a
28	Casing Top	111375	111375	111375	111793
29	Casing Flue Blank	111388	111388	111388	111586
30	Casing Flue Trim	111397	111397	111397	111587
31	Casing Top Insulation	111794	111794	111794	111789&111791
32	Casing Back Support	111596	111596	111596	111790
33	Control Panel	311670	311670	311670	313320
34	Casing Base	210914	210914	210914	211795
35	Flue Gasket	112104	112104	112104	112105
36	Flue Gas Analysis Blank	110923	110923	110923	110923
37	Filling Loop Hose	111341	111341	111341	111341
38	Double Check Valve	111332	111332	111332	111332
39	Compression Unit 15mm	111331	111331	111331	111331
40	System Pipe 3	110971	110971	110971	n/a
41	Pressure Vessel Hose	110660	110660	110660	110660
42	Stat Pocket	111317	111317	111317	111317
43	Pipe Work	See detail drawing	See detail drawing	See detail drawing	See detail drawing
44	Lagging Jacket	110917	110917	110917	111653
45	System Pipe 1	110969	110969	110969	111348
46	System Pipe 2	110970	110970	110970	n/a
47	Compression Unit 22mm	112000	112000	112000	n/a
48	Pump Valve	110644	110644	110644	110644
49	Recessed Pump Adapter	110648	110648	110648	110760
50	Safety Release Valve	111353	111353	111353	111353
51	Circulating Pump	410647	410647	410647	414040
52	Automatic Air Vent	111327	111327	111327	111327
53	Pressure Switch	110607	110607	110607	110607
54	Manual Air Vent	n/a	n/a	n/a	110645
55	Check Valve	n/a	n/a	n/a	111820
56	Elbow	n/a	n/a	n/a	110756
57	Gate Valve	n/a	n/a	n/a	110758
58	Reducing Bushing	n/a	n/a	n/a	110735
59	Reducing Bushing	n/a	n/a	n/a	110764
60	Reducing Nipple	n/a	n/a	n/a	110763
61	Nipple	n/a	n/a	n/a	110675
62	Pressure Switch Adapter	n/a	n/a	n/a	n/a

10 10.2 PARTS & BAFFLES - KITCHEN (BASIC) & COMMERCIAL UTILITY BOILERS

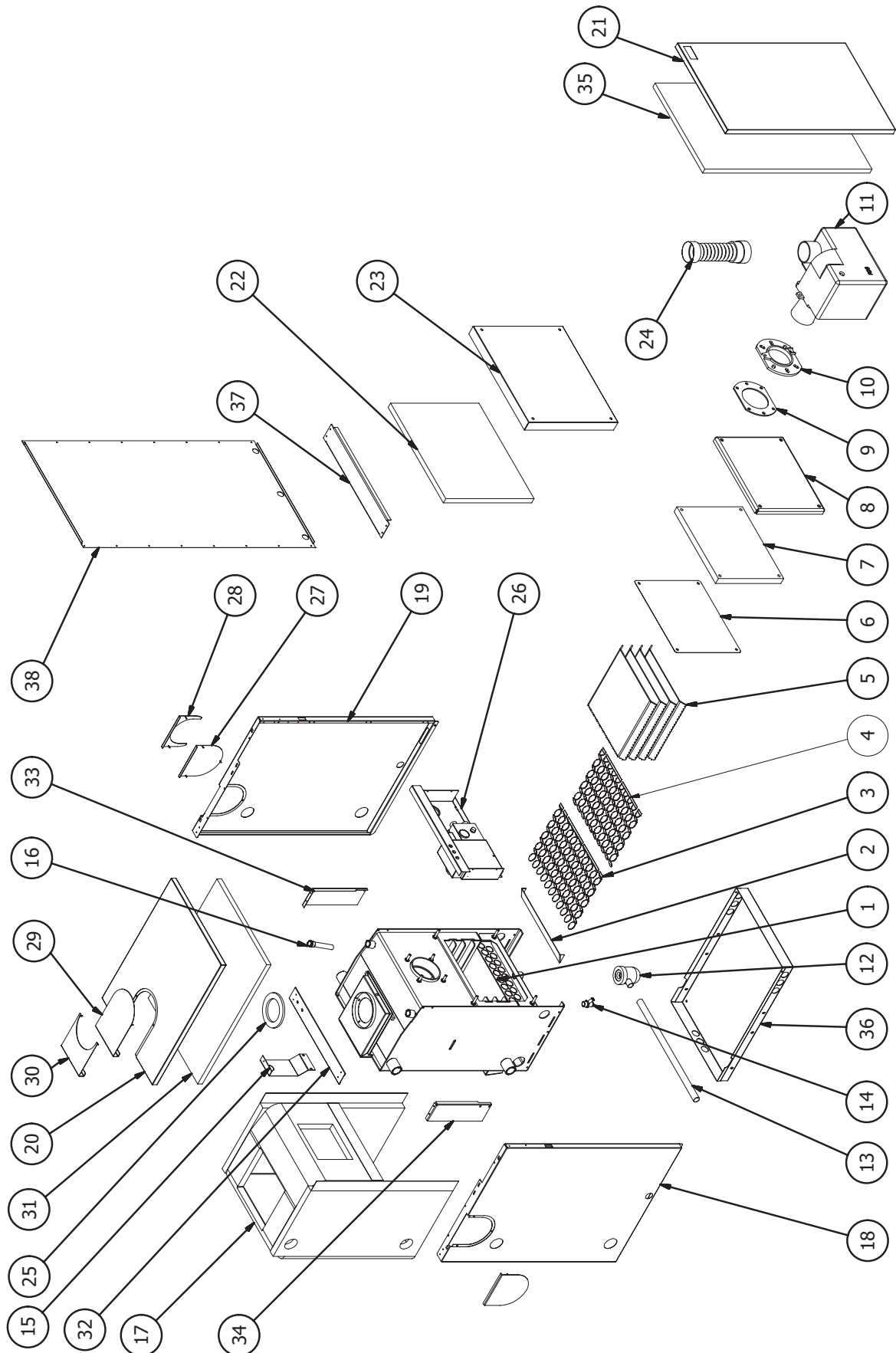

10 10.2 PARTS & BAFFLES - KITCHEN (BASIC) & COMMERCIAL UTILITY BOILERS

No.	Description	C12-18	C20/26	C35	C44	C58	C73	C100
1	Boiler Shell	312808	312026	312026	311634	311634	311481	312422
2	Heat Deflector	212810	210904	210904	211643	211643	211500	212420
3	Tube Baffle 1 Way	110908 (7 off)	110908 (5 off)	110908 (5 off)	111502 (8 off)	111502 (8 off)	111502 (11 off)	111502 (10 off)
4	Tube Baffle 4 Way	110907 (2 off)	110907 (4 off)	110907 (4 off)	111503 (6 off)	111503 (6 off)	111503 (6 off)	111503 (12 off)
5	Smoke Baffle	212809	212028 (4 off)	212122 (4 off)	211651 (8 off)	211640 (8 off)	211501 (8 off)	212419 (8 off)
6	Graphite Door Seal	111314	111314	111314	111646	111646	111511	112414
7	Door Gasket	112813	110918	110918	111645	111645	111506	112362
8	Boiler Door	212811	210910	210910	211644	211644	111505	212423
9	Burner Insulation Gasket	3005787	3005787	3005787	3005787	3005795	3005795	3005795
10	Burner Flange	3006384	3006384	3006384	3006384	3008637	3008637	3008637
11	Burner	413886	410206	410207	410209	410210	410210	410210
12	Condensate Trap	112184	112184	112184	112184	112184	112184	112184
13	Condensate Hose	111537	111537	111537	111537	111537	111537	111537
14	Drain Cock	111329	111329	111329	111329	111329	111329	111329
15	Back Bracket	210916	210916	210916	211770	211770	211591	213105
16	Stat Pocket	111317	111317	111317	111317	111317	111317	111317
17	Lagging Jacket	113029	110917	110917	111653	111653	111438	112633
18	Casing Left Panel	111377A	111377A	111377A	111761	111761	111580	213108
19	Casing Right Panel	111377B	111377B	111377B	111766	111766	111853	213111
20	Casing Top Panel	114102	111375	111375	111764	111764	111582	213120
21	Casing Front Panel	114103	111376	111376	111762	111762	111581	213122
22	Casing Door Insulation	n/a	n/a	n/a	n/a	n/a	n/a	112634
23	Casing Door Panel	n/a	n/a	n/a	n/a	n/a	n/a	212616
24	Air Hose	111902	111902	111902	111902	111902	110501	110501
25	Flue Gasket	112104	112104	112104	112105	112105	112713	112712
26	Control Panel	314111	311670	311670	311706	311706	311707	313117
27	Side Flue Blank	113031	113031	113031	n/a	n/a	n/a	n/a
28	Side Half Moon Blank	113032	113032	113032	n/a	n/a	n/a	n/a
29	Top Flue Blank	111388	111388	111388	111586	111586	111803	213121
30	Top Half Moon Blank	111397	111397	111397	111587	111587	111802	n/a
31	Top Panel Insulation	114105	111794	111794	111765 & 112011	111765 & 112011	111592 A&B	113124 & 113125
32	Casing Back Support	214104	111596	111596	111767	111767	111585	213116
33	Right Bracket	210915B	210915B	210915B	211805B	211805B	211806B	211590A
34	Left Bracket	210915A	210915A	210915A	211805A	211805A	211806A	211590B
35	Casing Front Insulation	114106	110937	110937	111763	111763	111593	113123
36	Casing Base	214101	210914	210914	211769	211769	211589	213106
37	Casing Top Stiffener	n/a	n/a	n/a	n/a	n/a	n/a	213104
38	Casing Back Panel	n/a	n/a	n/a	n/a	n/a	n/a	213119

10 10.3 - PARTS & BAFFLES - SLIMLINE SYSTEMPAC BOILER

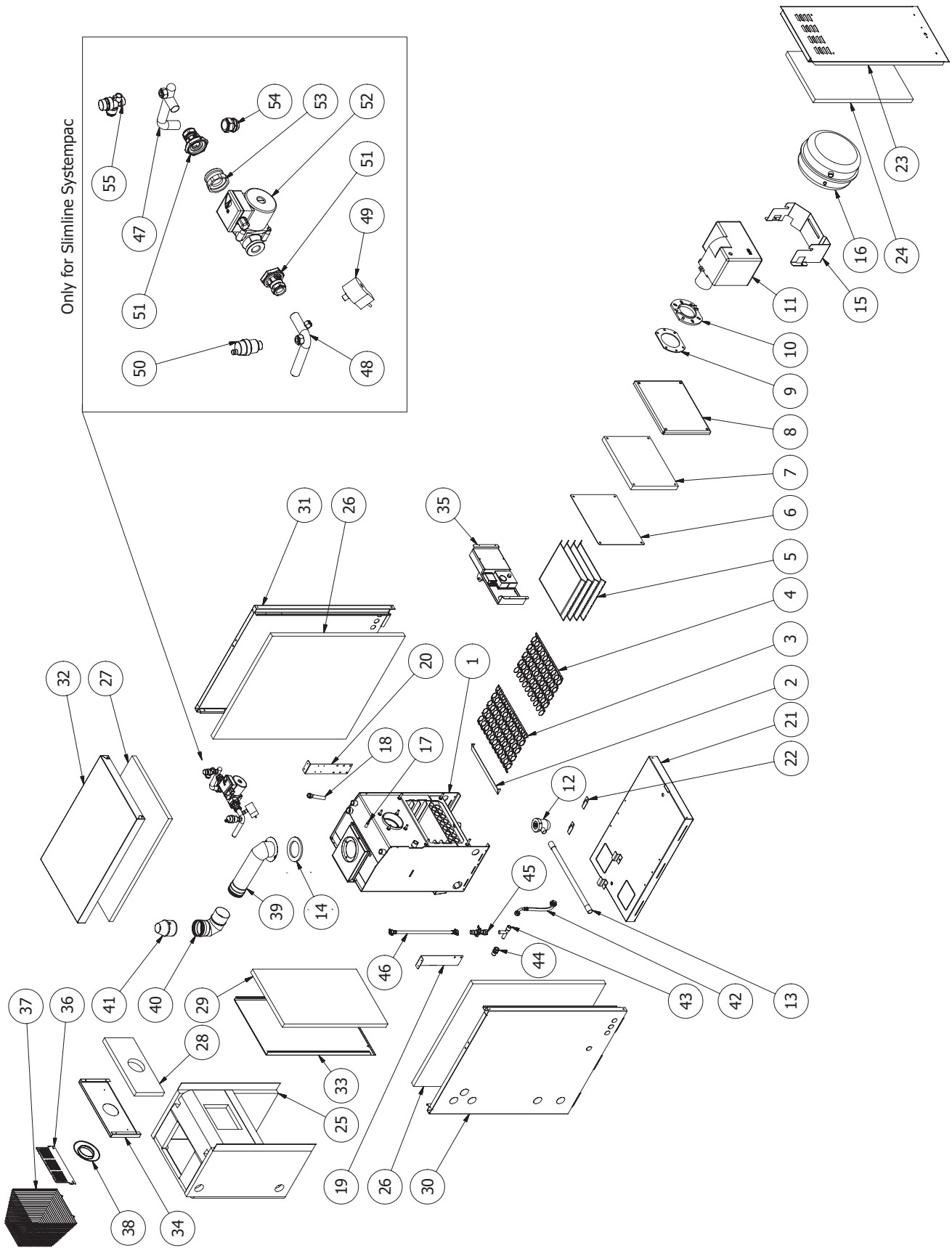

10 10.3 - PARTS & BAFFLES - SLIMLINE SYSTEMPAC BOILER

No.	Description	Slimline Heatpac C20, C26, C35	Slimline Systempac C20, C26, C35
1	Boiler Shell	312134	312733
2	Heat Deflector	210904	210904
3	Tube Baffle 1 Way	110908 (5 off)	110908 (5 off)
4	Tube Baffle 4 Way	110907 (4 off)	110907 (4 off)
5	20/26/35 kW smoke baffle	212022 / 212028 / 212122 (4 off)	212022 / 212028 / 212122 (4 off)
6	Door Gasket	111314	111314
7	Door Duroboard	110918	110918
8	Door	210910	210910
9	Burner Flange Gasket	ZE3005787	ZE3005787
10	Burner Flange	n/a	n/a
11	Burner	410205 / 401206 / 410207	410205 / 401206 / 410207
12	Condensate Trap	112184	112184
13	Condensate Hose 500mm	111537	111537
14	Flue Ring Gasket	112104	112104
15	Vessel Bracket	n/a	210962
16	12L Pressure Vessel	n/a	110658
17	Flangeless Plug	110923	110923
18	Stat Pocket	111317	111317
19	Left Top Bracket	211603	212894
20	Right Top Bracket	211603	211603
21	Casing Base	211594	211594
22	Boiler to Base Bracket	211600	211600
23	Casing Front	211604	211604
24	Casing Front Lagging	112010C	112010C
25	Boiler Lagging	110917	110917
26	Casing Side Lagging	112010D	112010D
27	Casing Top Lagging	112010E	112010E
28	Casing Flue Outlet Lagging	112010B	112010B
29	Casing Back Lagging	112010A	112010A
30	Casing Left Side	211607	211607
31	Casing Right Side	211608	211608
32	Casing Top	211609	211609
33	Casing Back	211605	211605
34	Casing Flue Outlet	211606	211606
35	Control Panel	311146	313261
-	Pressure Switch	n/a	110607
36	Terminal Guard Plate	213027	213027
37	Terminal Guard	111289	111289
38	Flue Seal	110721	110721
39	Flue Kit	411482	411482
40	Flue Bend 90°	413006	413006
41	Cone	412049	412049
42	Flexible Hose	n/a	n/a
43	System Pipe No. 3	n/a	110971
44	G1/2" to 15mm BSP Compression	n/a	111331
45	Double Check Valve	n/a	111332
46	Flexible Hose G 1/2" 400mm	n/a	111341
47	System Pipe No. 1	n/a	110969
48	System Pipe No. 2	n/a	110970
49	Pressure Switch	n/a	110607
50	Auto Air Vent	n/a	111327
51	Pump Valve	n/a	110644
52	Circulating Pump	n/a	410647
53	Recessed Pump Adaptor	n/a	110648
54	Compression Union	n/a	112000
55	Safety Release Valve	n/a	111353

10 10.4 - PARTS & BAFFLES - BURNER

DIESEL - LIGHT OIL BURNERS

RDB2.2R FIREBIRD 70D
 RDB2.2R FIREBIRD 90D
 RDB2.2R FIREBIRD 120D
 RDB2.2R FIREBIRD 150D

COD. 3515105
 COD. 3515305
 COD. 3515505
 COD. 3515506

TIPO/TYP/TYP 744T1R
 TIPO/TYP/TYP 744T3R
 TIPO/TYP/TYP 744T5R
 TIPO/TYP/TYP 744T5R

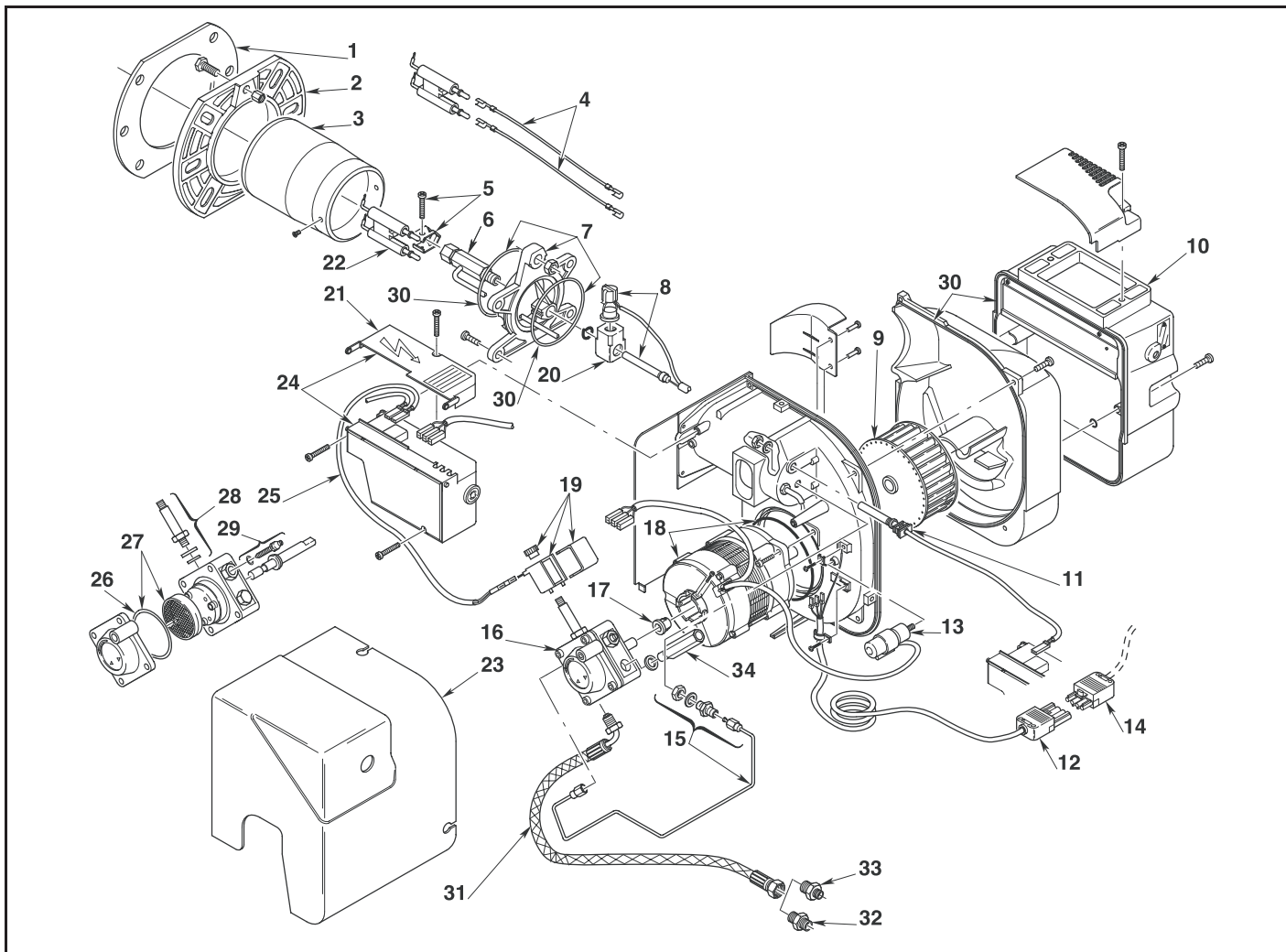

N.	COD.	COD.				DESCRIPTION
		3515105	3515305	3515505	3515506	
1	3005787	•	•	•	•	GASKET
2	3006384	•	•	•	•	FLANGE
3	3002507	•				CUP - SHAPED HEAD
3	3002447	•				CUP - SHAPED HEAD
3	3002533		•	•	•	CUP - SHAPED HEAD
4	3008794	•	•	•	•	HIGH VOLTAGE LEAD
5	3006552	•	•	•	•	ELECTRODE BRACKET
6	3008855	•	•	•	•	NOZZLE HOLDER
7	3008845	•	•	•	•	COLLAR
8	3002437	•	•	•	•	HEALTER ASSEMBLY
9	3005788	•	•	•	•	FAN
10	3008647	•	•			AIR DAMPER ASSEMBLY
10	3008839		•	•		AIR DAMPER ASSEMBLY
11	3008646	•	•	•	•	P.E. CELL
12	3002657	•	•	•	•	4 POLE SOCKET
13	3002837	•	•	•	•	CAPACITOR 4,5 µF
14	3007418	•	•	•	•	4 PIN PLUG
15	3008842	•	•	•	•	TUBE AND CONNECTOR
16	3020475	•	•	•	•	PUMP

N.	COD.	COD.				DESCRIPTION
		3515105	3515305	3515505	3515506	
17	3000443	•	•	•	•	JOINT
18	3002836	•	•	•	•	MOTOR + CAPACITOR
19	3008648	•	•	•	•	COIL
20	3008856	•	•	•	•	CONNECTOR
21	3008649	•	•	•	•	PROTECTION
22	3007513	•	•	•	•	ELECTRODE ASSEMBLY
23	3008879	•	•	•	•	COVER
24	3008652	•	•	•	•	CONTROL BOX
25	3008851	•	•	•	•	LEAD COIL
26	3007162	•	•	•	•	O-RING
27	3008653	•	•	•	•	FILTER - O-RING
28	3007582	•	•	•	•	NEEDLE VALVE
29	3008651	•	•	•	•	REGULATOR
30	3008878	•	•	•	•	KIT SEALS
31	3007621	•	•	•	•	FLEXIBLE
32	3003602	•	•	•	•	CONNECTOR 3/8 - 1/4
33	3009068	•	•	•	•	CONNECTOR 3/8 - 3/8
34	3008876	•	•	•	•	PRESSURE GAUGE

DIESEL - LIGHT OIL BURNERS

RDB3 FIREBIRD 150K
RDB4 FIREBIRD 200K
RDB4.2 FIREBIRD C58/200K

COD. **3748965**
 COD. **3748965**
 COD. **3748965**

TYPE**489 T50**
 TYPE**488 T50**
 TYPE**490 T61**

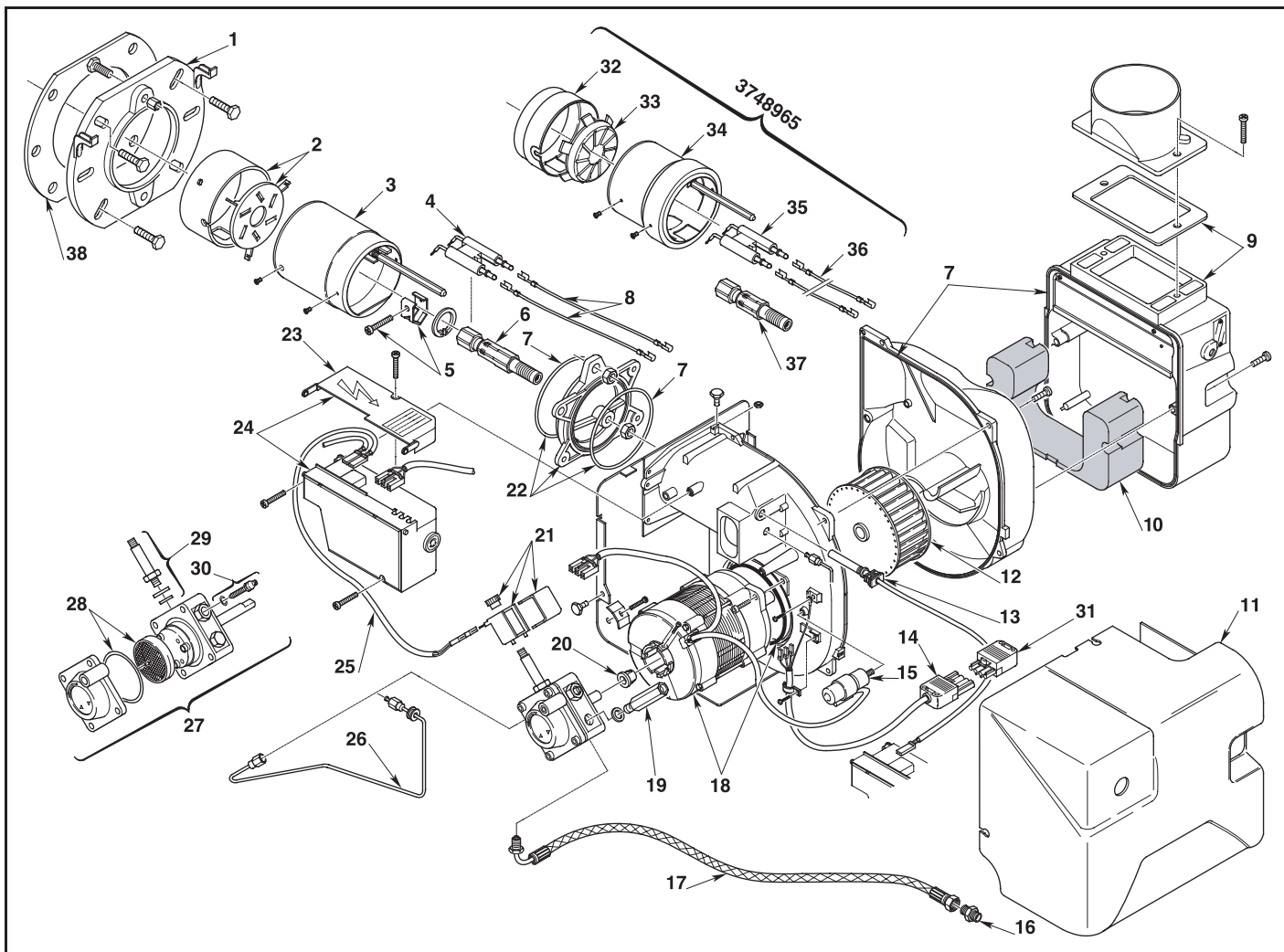

N.	COD.	3748965	3748860	3748861	DESCRIPTION
1	3008637	•	•	•	FLANGE
2	3006392		•	•	END RING AND DIFFUSER DISC
3	3006151	•	•	•	BLAST TUBE ASSEMBLY
4	3008538		•	•	ELECTRODE ASSEMBLY
5	3006552	•	•	•	ELECTRODE BRACKET
6	3008954		•	•	NOZZLE HOLDER
7	3008963	•	•	•	KIT SEALS
8	3008956		•	•	HIGH VOLTAGE LEAD
9	3008839	•	•	•	AIR DAMPER ASSEMBLY
10	3008958	•	•	•	DEADENING
11	3008962	•	•	•	COVER
12	3005799	•	•	•	FAN
13	3008646	•	•	•	P.E. CELL
14	3002657	•	•	•	4 POLE SOCKET
15	3008960	•	•	•	CAPACITOR 5 µF
16	3003602	•	•	•	CONNECTOR
17	3005720	•	•	•	FLEXIBLE OIL LINE
18	3008964	•	•	•	MOTOR
19	3008876	•	•	•	PRESSURE GAUGE
20	3000443	•	•	•	JOINT

N.	COD.	3748965	3748860	3748861	DESCRIPTION
21	3008648	•	•	•	COIL + SHELL AND KNOB
22	3008957	•	•	•	COLLAR
23	3008649	•	•	•	PROTECTION
24	3008652	•	•	•	CONTROL BOX 535SE/LD
25	3008851	•	•	•	LEAD COIL
26	3008961	•	•	•	TUBE
27	3020475	•	•	•	PUMP
28	3008653	•	•	•	FILTER - O-RING
29	3007582	•	•	•	NEEDLE VALVE
30	3008651	•	•	•	REGULATOR
31	3007418	•	•	•	4 PIN PLUG
32	3005714	•			END RING
33	3005713	•			DIFFUSER DISC
34	3007714	•			BLAST TUBE ASSEMBLY
35	3007513	•			ELECTRODE ASSEMBLY
36	3008794	•			HIGH VOLTAGE LEAD
37	3008955	•			NOZZLE HOLDER
38	3005795	•	•	•	GASKET

STANDARDS & REGULATIONS

To ensure the highest standards of installation & safety, it is important that the boiler be installed in compliance with the following regulations where applicable. It is the responsibility of the installer and everyone concerned with any aspect of installation to ensure that all applicable standards and regulations are fully adhered to.

All **CURRENT** editions of the appropriate Building regulations:

AS1691-1985 Domestic Oil-Fired Appliances - Installation

All requirements of the New Zealand Building Code.

In addition, the work must comply with OFTEC Installation requirements for oil fired boilers and oil storage tanks.

OFTEC also publish excellent guides including: Safe working practices for Oil Fired Technicians - OFTEC Technical Book Three (Installation requirements for Oil Fired Boilers and Oil Storage Tanks) - OFTEC Technical Book Four (Domestic Heating Systems) and it is recommended that these should adhere to Domestic Heating Design Guide.

OFTEC PUBLICATIONS ARE AVAILABLE FROM:
**OFTEC, Oil Firing Technical Association,
Foxwood House, Dobbs Lane,
Kesgrave, Ipswich, IP5 2QQ.
www.oftec.org**

PRE- INSTALLATION CHECKS

The installer should also be aware of his/her responsibilities under The Health and Safety at Work Act. The interests of safety are best served if the boiler is installed and commissioned by a competent engineer, OFTEC trained and registered.

BOILER INSTALLATION:

Other than special considerations for condensate removal and plume dispersal, the installation of Diesel firing condensing boilers is the same as for non-condensing boilers.

For condensing boilers, the same requirements apply for installation with regard to cleaning and flushing and providing inhibitors as are followed for any other boiler. Manufacturers instructions must always be followed.

12 TERMS & CONDITIONS OF WARRANTY

Firebird products are designed and manufactured to give many years of trouble free service.

The terms laid down in the warranty must be adhered to.

- ◆ Firebird provides a comprehensive, conditional warranty of 5 years on the boiler shell and 2 years on all other parts from date of installation, provided installation has occurred within 12 months from date of purchase.
- ◆ The 5 year boiler shell warranty consists of parts and labour for the first 3 years and parts only for years 4 and 5.
- ◆ The warranty will only apply if the boiler is commissioned by an OFTEC registered or competent, qualified engineer and is serviced annually thereafter.
- ◆ Please ensure that the commissioning card is fully completed by a competent, qualified engineer and is returned to Central Heating New Zealand within 28 days of complete installation and commissioning.
- ◆ Correct commissioning will ensure that your boiler is set to operate at its maximum fuel efficiency.
- ◆ Consumable components, the nozzles and the oil hose are excluded.

TERMS & CONDITIONS OF WARRANTY

1. Warranty implies that the product shall be free from defective parts or workmanship for a period of warranty cover, which begins from the date of installation.
2. All claims under the warranty programme must be within the time limits stated on the left.
3. Installation and commissioning of the product must be in accordance with (a) instruction/technical manuals (b) all relevant standards and codes of practice.
4. A competent, qualified engineer, using the correct installation and test equipment must carry out installation and commissioning.
5. This warranty does not cover special, incidental or consequential damages, injury to persons or property, or any other consequential loss.
6. Maintenance should be carried out at the intervals stated in the instruction/technical manual.
7. Firebird accepts no liability in respect of any defect arising from incorrect installation, negligence, fair wear and tear, misuse, alteration or repair by unqualified persons.
8. Firebird will not accept any liability in respect of any defect occurring to the product due to limescale build-up and or low return water temperature.
9. The warranty programme extends to reasonable labour costs EXCEPT in the case of a 5 year warranty period whereby any valid claim made after 3 years will not include labour costs.
10. Firebird's prior authorisation must be obtained before examination or repair of the product takes place.
11. Firebird will examine all claims made under the warranty programme and for any claims that are deemed invalid, the costs incurred will be borne by the owner.
12. The warranty programme only applies where the product was used for normal domestic heating purposes.
13. Any defective part removed under any or all of the warranty programmes MUST be returned to Central Heating New Zealand.
14. Burner controls and flue kits (supplied by Firebird), will be free from defective parts or workmanship for a period of 2 years from the date of installation (with the exception of burner nozzles, which must be replaced at the recommended service intervals).

*STATUTORY RIGHTS OF THE OWNER ARE NOT
AFFECTED BY THIS WARRANTY*

**The commissioning card below
must be returned to
Central Heating New Zealand
within 28 days of installation
to validate the warranty.**

COMMISSIONING CARD

TEAR OFF HERE & RETURN TO THE APPROPRIATE ADDRESS

END USER (In block capitals)

INSTALLER (In block capitals)

NAME

NAME

ADDRESS

ADDRESS

POSTCODE TEL

POSTCODE TEL

COMMISSIONING CHECK DETAILS

BOILER MODEL

OUTPUT

SERIAL NUMBER

- Burner Model**
- Diesel Type
- Nozzle Type
- Nozzle Size
- Nozzle Angle
- Pump Pressure
- Air
- Smoke Reading
- Flue Draft in W.C.

- CO₂%
- Condensate Trap Primed
- F.G.T. °C
- Flue Seal
- Gaskets
- Fire Valve Location
- CHECK**
- Water
- All Connections

- Baffles
- Baffles in position and correct
- CHECK**
- Central Heating
- Flow Switch
- Power Supply

DATE NAME

ADDRESS

COMMISSIONING COMPANY

SIGNATURE

POSTCODE TEL



FIREBIRD
HEATING SOLUTIONS

For further information on Firebird products, please contact:

Central Heating New Zealand Ltd.,

52 Pilkington Way,

Wigram,

Christchurch 8042,

New Zealand.

Tel: + (0) 64 3357 1233

www.centralheating.co.nz

© Copyright applies to all FIREBIRD products. Our policy is one of continual development and we therefore reserve the right to change without prior notice the specification of our products at any time and be without obligation to make similar changes in products previously produced.

MLOBNZ001