

# BAXI

## LUNA DUO-TEC

### MP+ 1.115 - 1.130 - 1.150

<b>it</b>	<b>CALDAIA MURALE A GAS A CONDENSAZIONE</b> <i>Manuale per l'uso destinato all'utente e all'installatore</i>
<b>en</b>	<b>CONDENSING GAS WALL-HUNG BOILERS</b> Instructions manual for users and fitters
<b>de (AT)</b>	<b>KONDENSATIONS-WANDGASHEIZKESSEL</b> Gebrauchsanleitung für den Benutzer und Installateur
<b>es</b>	<b>CALDERA MURAL DE GAS A CONDENSACIÓN</b> Manual de uso destinado al usuario y al instalador



Dear Customer,  
 Our company is confident our new product will meet all your requirements. Buying one of our products guarantees all your expectations: good performance combined with simple and rational use.  
 Please do not put this booklet away without reading it first: it contains useful information for the correct and efficient use of your product.

Our company declares that these products are marked **CE** in compliance with the essential requirements of the following Directives:

- Gas regulation (EU) **2016/426**
- Efficiency Directive **92/42/EEC**
- Electromagnetic Compatibility Directive **2014/30/EU**
- Low Voltage Directive **2014/35/EU**
- Ecodesign directive **2009/125/EC**
- Regulation (EU) No **2017/1369** (for boilers with Power<70kW)
- Ecodesign regulation (EU) No **813/2013**
- Energy labelling regulation (EU) No **811/2013** (for boilers with Power<70kW)

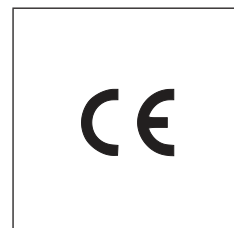

Our company, constantly striving to improve the products, reserves the right to modify the details given in this documentation at any time and without notice. These Instructions are only meant to provide consumers with use information and under no circumstance should they be construed as a contract with a third party.

**The appliance can be used by children aged 8 or over and by people with reduced physical, sensory or mental faculties, or who do not have the required experience or knowledge, provided they are supervised or have received instructions on using the appliance safely and understanding its intrinsic hazards. Children must not play with the appliance. The cleaning and maintenance operations reserved to the user must not be performed by unsupervised children.**

## CONTENT

DESCRIPTION OF SYMBOLS .....	26
SAFETY WARNINGS .....	26
GENERAL PRECAUTIONS .....	27
ENERGY-SAVING TIPS .....	27
1. COMMISSIONING THE BOILER .....	28
1.1 ADJUSTING THE CH AND DHW FLOW TEMPERATURE .....	28
1.2 OPERATING MODES .....	28
2. PROLONGED SHUTDOWN. ANTI-FREEZE PROTECTION .....	29
3. GAS CONVERSION .....	29
4. FAULTS .....	29
5. BOILER INFORMATION MENU .....	30
6. FILLING THE SYSTEM .....	30
7. ROUTINE MAINTENANCE INSTRUCTIONS .....	30
8. SWITCHING OFF THE BOILER .....	30
9. INSTALLING THE BOILER .....	31
9.1 BOILER PUMP .....	31
10. INSTALLING THE DUCTS .....	32
10.1 CONCENTRIC DUCTS .....	32
10.2 SEPARATE DUCTS .....	32
10.3 CASCADE FLUES .....	33
11. ELECTRICAL CONNECTIONS .....	33
11.1 CONNECTING THE ROOM THERMOSTAT .....	34
11.2 ACCESSORIES NOT INCLUDED IN THE SUPPLY .....	34
12. INITIAL IGNITION - SPECIAL FUNCTIONS .....	37
12.1 SYSTEM GAS EXTRACTION FUNCTION .....	37
12.2 CALIBRATION FUNCTION .....	37
12.3 CHIMNEY SWEEPER .....	37
13. FAULTS THAT CANNOT BE RESET BY THE USER .....	37
14. PARAMETERS SETTING .....	38
15. GAS VALVE CALIBRATION .....	40
15.1 GAS CONVERSION .....	40
16. ADJUSTMENT AND SAFETY DEVICES .....	41
17. PUMP CAPACITY/ HEAD .....	41
18. ANNUAL SERVICING .....	42
18.1 CLEANING THE CONDESATE TRAP .....	42
18.2 CLEANING THE HEAT EXCHANGER FUMES SIDE .....	42
18.3 CHECKING THE BURNER .....	43
18.4 COMBUSTION PARAMETERS .....	43
19. THERMAL FUSE REPLACEMENT OF HEAT EXCHANGER .....	44
20. DISMANTLING, DISPOSAL AND RECYCLING .....	44
21. TECHNICAL SPECIFICATIONS .....	45
22. TECHNICAL PARAMETERS .....	46
23. PRODUCT FICHE .....	47

User & Installer (en)

## DESCRIPTION OF SYMBOLS



### WARNING

Risk of damage to, or malfunction of the appliance. Pay special attention to the warnings concerning danger to people.



### DANGER OF BURNS

Wait for the appliance to cool down before working on the parts exposed to heat.



### DANGER - HIGH VOLTAGE

Live components - electrocution hazard.



### DANGER OF FREEZING

Possible formation of ice due to low temperatures.



### IMPORTANT INFORMATION

Information to read with particular care as it is useful for the correct operation of the boiler.



### GENERIC PROHIBITION

It is forbidden to do/use the things indicated alongside the symbol.

## SAFETY WARNINGS

### SMELL OF GAS

- Switch off the boiler.
- Do not activate any electrical device (such as switching on the light).
- Put out any naked flames and open the windows.
- Call an Authorised Service Centre.

### SMELL OF COMBUSTION FUMES

- Switch off the boiler.
- Open all the doors and windows to ventilate the room.
- Call an Authorised Service Centre.

### FLAMMABLE MATERIAL

Do not use and/or store highly flammable material (thinners, paper, etc.) near the boiler.

### SERVICING AND CLEANING THE BOILER

Switch off the boiler before working on it.



The appliance is not intended to be used by persons with reduced physical, sensory or mental capacities, or who lack experience or knowledge, unless, through the mediation of a person responsible for their safety, they have had the benefit of supervision or of instructions on the use of the appliance.



**BAXI** a leading European manufacturer of hi-tech boilers and heating systems, has developed CSQ-certified quality management (ISO 9001), environmental (ISO 14001) and health and safety (OHSAS 18001) systems. This means that BAXI S.p.A. includes among its objectives the safeguarding of the environment, the reliability and quality of its products, and the health and safety of its employees.

Through its organisation, the company is constantly committed to implementing and improving these aspects in favour of customer satisfaction.



## GENERAL PRECAUTIONS

This boiler has been designed to heat water to a temperature lower than boiling point at atmospheric pressure. It must be connected to a central heating system and to a domestic hot water supply system according to its performance and power output. Before having the boiler installed by a qualified service engineer, make sure the following operations are performed:

- Make sure that the boiler is adjusted to use the type of gas delivered by the gas supply. To do this, check the markings on the packaging and the data label on the appliance.
- Make sure that the flue terminal draft is appropriate, that the terminal is not obstructed and that no exhaust gases from other appliances are expelled through the same flue duct, unless the latter has been specially designed to collect exhaust gas from more than one appliance, in compliance with current laws and regulations.
- Make sure that, if the boiler is connected to existing flue ducts, these have been thoroughly cleaned as residual products of combustion may detach from the walls during operation and obstruct the flow of fumes.
- To ensure correct operation and maintain the warranty, observe the following precautions:

### 1. DHW circuit

**1.1** If the water is harder than 20 °F (1 °F = 10 mg calcium carbonate per litre of water), install a polyphosphate dispenser or an equivalent treatment system, compliant with current regulations.

**1.2** Thoroughly flush the system after installation of the appliance and before use.

**1.3** The materials used for the DHW circuit comply with Directive 98/83/EC.

### 2. Heating circuit

**2.1 New system:** Before installing the boiler, the system must be cleaned and flushed to eliminate residual thread-cutting swarf, solder and any solvents, using suitable off-the-shelf non-acid and non-alkaline products that do not damage metal, plastic and rubber parts. To protect the system from scale, use inhibitors such as SENTINEL X100 and FERNOX protector for heating circuits. Use these products in strict compliance with the manufacturers' instructions.

**2.2 Existing system:** Before installing the boiler, drain the system and clean it to remove sludge and contaminants, using suitable proprietary products. Recommended cleaning products are: SENTINEL X300 or X400 and FERNOX regenerator for heating circuits. Use these products in strict compliance with the manufacturers' instructions. Remember that the presence of foreign bodies in the heating system can adversely affect boiler operation (e.g. overheating and excessive noise of the heat exchanger).

Initial lighting of the boiler must be carried out by an authorised Service Engineer who must first ensure that:

- The rated data correspond to the supply (electricity, water and gas) data.
- That the installation complies with current regulations.
- The appliance is correctly connected to the power supply and earthed.



The appliance must be installed in a ventilated boiler room pursuant to current regulations (appliances with heating capacity > 40 kW).



Failure to observe the above will render the warranty null and void. Prior to commissioning, remove the protective plastic coating from the boiler. Do not use any tools or abrasive detergents to do this as you may damage the painted surfaces.



Do not leave any packaging (plastic bags, polystyrene, etc.) within the reach of children as they are a potential source of danger.

## ENERGY-SAVING TIPS

### Adjustment in the heating mode

Adjust the boiler flow temperature depending on the kind of system. For systems with radiators, set a maximum heating water flow temperature of approximately 60°C, and increase this value if the required room temperature is not reached. For systems with radiant floor panels, do not exceed the temperature indicated by the system designer. Use the External Sensor and/or Control Panel to automatically adjust the flow temperature to atmospheric conditions or the indoor temperature. This ensures that no more heat than that effectively necessary is produced. Use room thermostats to adjust the temperature without overheating the rooms. Every extra degree centigrade means consuming approximately 6% more. Also room ambient temperature depending on how the rooms are used. For example, the bedroom or the least used rooms can be heated to a lower temperature. Use the programmable timer and set the night-time room temperature at approximately 5°C lower than that during the day. There is no appreciable saving to be achieved by setting it any lower. Only in case of a prolonged absence, such as a holiday, should the temperature setpoint be lowered. Do not cover radiators as this prevents the air from circulating correctly. Do not leave the windows partially open to ventilate the rooms but open them completely for a short period.



### Domestic hot water

Setting the domestic hot water at the required temperature without mixing it with cold water saves a lot of money. Additional heating wastes energy and creates additional scale.





# 1. COMMISSIONING THE BOILER

To light the boiler correctly, proceed as follows:

- Check that the system pressure is correct (section 6);
- Power the boiler;
- Open the gas tap (yellow, positioned under the boiler);
- Select the required heating mode (section 1.2).







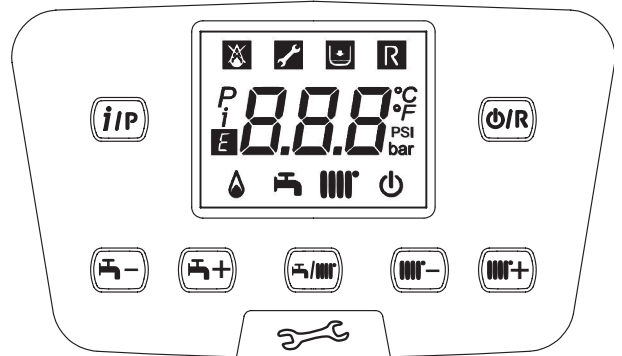





 During initial ignition, the burner may not ignite (causing the boiler to shut down) until any air in the gas pipes is vented. In this case, repeat the ignition procedure until gas reaches the burner. To reset boiler operation, press  for at least 2 seconds.

## Key to BUTTONS

	DHW temperature adjustment (+ to increase the temperature and – to decrease it)
	Heating water temperature adjustment (+ to increase the temperature and – to decrease it)
	Boiler operating information
	Operating mode: DHW – DHW & Heating – Heating Only
	Off – Reset – Exit menu/functions



## Key to SYMBOLS

	Off: heating and DHW disabled (only boiler anti-freeze protection is active)		Burner lit
	Fault preventing the burner from lighting		DHW operating mode enabled
	Boiler/system water pressure low		Heating mode enabled
	Technical Service Centre call-in		Programming menu
	Manually resettable fault (  )		Boiler information menu
	Fault in progress		Set unit of measurement (SI/US)

## 1.1 ADJUSTING THE CH AND DHW FLOW TEMPERATURE



Press  and  respectively to adjust the CH and DHW flow temperature (if an external storage boiler is fitted). When the burner is lit, the display shows the symbol .

**HEATING:** while the boiler is operating in the heating mode, the display shows the flashing symbol  and the heating delivery temperature (°C).



When connected to an External Sensor,  indirectly adjust the room temperature (factory setting 20°C).

**DHW:** connect an external storage boiler to produce domestic hot water. While the boiler is operating in the DHW mode, the display shows the flashing symbol  and the heating flow temperature (°C).

## 1.2 OPERATING MODES

SYMBOL DISPLAYED	OPERATING MODE
	DHW
	DHW & HEATING
	HEATING ONLY

To enable the appliance in **DHW - Heating** or **Heating only** press  repeatedly and choose one of the three available modes.

To disable the boiler operating modes whilst keeping the anti-freeze function enabled, press . Just the symbol  appears on the display (with the boiler not blocked).

## 2. PROLONGED SHUTDOWN. ANTI-FREEZE PROTECTION

Do not drain the whole system as filling up with water again could cause unnecessary and harmful scale to build up inside the boiler and the heating elements. If the boiler is not used during winter and is therefore exposed to the danger of frost, add some specific anti-freeze to the water in the system (e.g.: propylene glycol coupled with corrosion and scale inhibitors). The electronic boiler management system includes a "frost protection" function for the heating system which, when delivery temperature falls below 5°C, lights the burner until a delivery temperature of 30°C is reached.



*The function is operative if: the boiler is electrically powered, there is gas, system pressure is normal and the boiler is not blocked.*

## 3. GAS CONVERSION

The boilers can operate both on natural gas (G20) and LPG (G31). All gas conversions must be made by the AUTHORISED TECHNICAL SERVICE CENTRE.

## 4. FAULTS

The faults shown on the display are identified with the symbol **E** and a number (fault code). For a complete list of faults, see the following table.

If **R** appears on the display the fault must be RESET by the user. To RESET the boiler, press **⏻/R**. If faults are displayed frequently, call the Authorised Service Engineer.

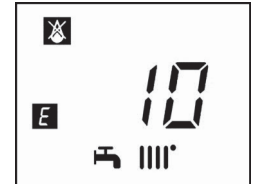

<b>E</b>	Description of fault	<b>E</b>	Description of fault
10	External probe sensor	128	No flame
20	NTC flow sensor	130	Fumes NTC tripped due to overtemperature
28	NTC fumes sensor	133	Ignition failure (4 attempts)
40	NTC flow sensor	151	Boiler board internal fault
50	NTC DHW sensor (only for heating-only model with storage boiler)	152	Generic parameter setting error
52	Solar DHW sensor (if connected to a solar plant)	153	Forced reset when the Reset button is pressed and held for more than 10 seconds (see section "FAULTS THAT CANNOT BE RESET BY THE USER")
73	Solar manifold sensor (if connected to a solar plant)	160	Fan fault
83	Communication problem between boiler board and control unit. Probable short circuit on wiring.	162	Flue pressure switch action (see section "FAULTS THAT CANNOT BE RESET BY THE USER")
84	Address conflict between control units (internal fault)	321	NTC domestic hot water sensor faulty
98	Accessory not detected or recognized (*)	343	Generic parameter setting error of solar plant (if connected to a solar plant)
109	Air in boiler circuit (temporary fault)	384	Abnormal light (parasite flame – internal fault)
110	Safety thermostat/thermal fuse/exchanger flange thermostat (**) tripped due to over temperature (pump probably blocked or air in heating circuit)	385	Input voltage too low
111	Safety thermostat tripped due to overtemperature.	386	Fan speed threshold not reached
117	Pressure in hydraulic circuit too high	430	No circulation safety trip (control performed via a pressure sensor)
118	Pressure in hydraulic circuit too low	432	No functional hearth or safety thermostat tripped due to over temperature (E110)
125	No circulation safety trip (control performed via a temperature sensor)		

(\*) After powering up the boiler (or after a Reset for lockout), the error appears on the display once the self-check is completed. The fault code is displayed permanently if the accessory is not recognized.

(\*\*) See Section "ADJUSTMENT AND SAFETY DEVICES".



*In the event of a fault, the display backlighting indicates the error code. 5 reset attempts can be performed after which the boiler shuts down. Wait 15 minutes before attempting to reset the boiler again.*

## 5. BOILER INFORMATION MENU

Press **[iP]** to display the information indicated in the following table. Press **[o/R]** to exit.

<b>i</b>	<b>Description</b>	<b>i</b>	<b>Description</b>
<b>00</b>	SW Diagnostic Code	<b>12</b>	Ion current
<b>01</b>	Heating flow temperature	<b>13</b>	Burner working hours
<b>02</b>	Outdoor temperature (if the outdoor sensor is fitted)	<b>14</b>	Zone 1 heating mode
<b>03</b>	External storage tank temperature (fitted models)	<b>15</b>	Zone 2 heating mode
<b>04</b>	DHW temperature (fitted models)	<b>16</b>	DHW circuit operating mode
<b>05</b>	Water pressure in heating system	<b>17</b>	Boiler operating mode
<b>06</b>	Heating return temperature	<b>18</b>	Solar plant operating mode
<b>07</b>	Flue sensor temperature	<b>19</b>	Manufacturer information
<b>08</b>	Not used	<b>20</b>	Manufacturer information
<b>09</b>	Solar collector temperature	<b>21</b>	Gas energy consumption in HEATING
<b>10</b>	Zone 1 heating flow temperature	<b>22</b>	Gas energy consumption in DHW
<b>11</b>	Zone 2 heating flow temperature	<b>23</b>	Gas energy consumption in HEATING + DHW



Items 21, 22 and 23 are displayed alternatively with the gas energy consumption value expressed in millions, thousands and units of kWh. e.g.:  $\dot{I}21 / 033 / 145 / 827$  corresponds to a gas energy consumption in HEATING of 33.145.827 kWh.

## 6. FILLING THE SYSTEM

Periodically check that the pressure displayed on the pressure gauge is **1 - 1.5 bar**, when the system water temperature is cold. If the pressure is lower, turn the system filling tap installed by the installer. Open the tap very slowly in order to vent the air.



The boiler is fitted with a hydraulic pressure gauge which prevents the boiler from working if there is no water.



*If pressure drops occur frequently, have the boiler checked by the **AUTHORISED TECHNICAL SERVICE CENTRE**.*

## 7. ROUTINE MAINTENANCE INSTRUCTIONS

To keep the boiler efficient and safe, have it checked by the Authorised Service Centre at the end of every operating period. Careful servicing ensures economical operation of the system.

## 8. SWITCHING OFF THE BOILER

To turn off the boiler, disconnect the electric power supply using the two-pole switch. In the "Off" operating mode **[o]** the boiler stays off but the electrical circuits remain powered and the anti-freeze function remains active.



## INSTRUCTIONS PRIOR TO INSTALLATION

The following notes and instructions are addressed to installers to allow them to carry out trouble-free installation. Instructions for igniting and using the boiler are contained in the 'Instructions for Users' section. The installation must satisfy the requirements of standards and local by-laws and technical regulations.

Moreover, the installation technician must be qualified to install heating appliances. Additionally, bear in mind the following:

- When installing the unit in environments with temperatures lower than 0°C, take the necessary precautions to avoid the formation of ice in the siphon and in the condensation drain
- The boiler can be used with any kind of convector plate, radiator or thermoconvector. Design the system sections as usual, though, bearing in mind the available capacity-head at the plate (see annex "SECTION" E at the end of this manual).
- Initial ignition of the boiler must be carried out by the Authorised Service Centre (as indicated on the attached sheet).

**Failure to observe the above will render the warranty null and void.**



When supplied, the boiler is not fitted with the following components: **EXPANSION VESSEL - SYSTEM FILLING TAP - HYDRAULIC SEPARATOR**. These must be mounted by the installer.



Do not leave any packaging (plastic bags, polystyrene, etc.) within the reach of children as they are a potential source of danger.

## 9. INSTALLING THE BOILER



After fixing the boiler on the wall, replace the cap at the bottom of the siphon with the one in the pack, reusing the ring nut and referring to the figure. Fill the siphon and check it for any leaks.



Take special care when filling the heating system. In particular, open any thermostat valves in the system, ensure the water enters slowly in order to prevent the formation of air inside the primary circuit until operating pressure is reached. Lastly, vent any radiators in the system. BAXI declines all liability for damage deriving from the presence of air bubbles in the primary exchanger due to the incorrect or imprecise observance of the above.



Tighten the boiler water connections with care (maximum tightening torque 30 Nm).



Before starting up the boiler, fill the water siphon to prevent the fumes from diffusing in the room.

The template outline is shown in annex "SECTION" C at the end of this manual.

After deciding the exact location of the boiler, fix the template to the wall. Connect the system to the gas and water inlets present on the lower bar of the template. Make sure the rear part of the boiler (back) is as parallel as possible to the wall (otherwise, shim the lower part). Fit two G1-1/2" taps (flow and return) on the central heating circuit; these taps make it possible to carry out important operations on the system without draining it completely. On the Italian market, the system must comply with Raccolta R safety provisions (limit thermostat, safety pressure switch, fuel cut-off valve, etc..). Fit a hydraulic separator, sized according to maximum boiler and system pressure, downline from the hydraulic connectors of the boiler. If you are either installing the boiler on an existing system or replacing one, as well as the above, fit a settling tank under the boiler on the system return line in order to collect any deposits and scale circulating in the system after flushing. After fixing the boiler to the template, connect the flue and air ducts, supplied as accessories, as described in the following sections. Connect the siphon to a drain trap, making sure the slope is continuous. Avoid horizontal stretches. The boiler is electronically fitted out for connection to an external storage boiler.

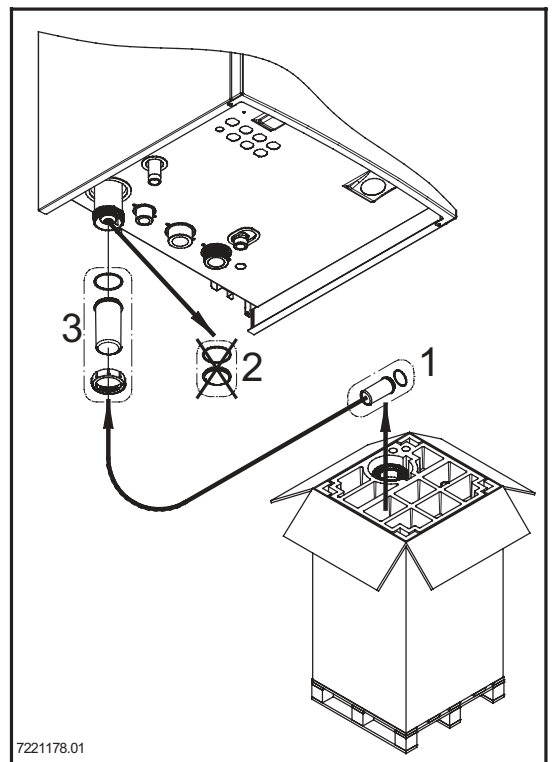

INSTALLER Section (en)



Do not lift the boiler exerting pressure on the plastic parts like the siphon and the flue turrett.

### 9.1 BOILER PUMP

The boiler pump (15 - "SECTION" A) is modulating and circulates the water between the boiler and the hydraulic separator (for hydraulic performance see the charts in annex "SECTION" E). The water in the system is circulated by the relative pumps (see section 11.2.3).

Check that the flow of the water circulating in the boiler is not less than the value indicated in the following table:

Model	Minimum flow rate (l/h)	Operating flow rate (l/h) with BAXI hydraulic separator
1.115 - 1.130	2250	5400
1.150	3150	5600



## 10. INSTALLING THE DUCTS

The boiler is easy and flexible to install thanks to the extensive range of available accessories, as described below. The boiler has been designed for connection to a vertical or horizontal coaxial flue-air duct. The boiler can also be used with separate ducts using the accessory splitting kit.

### WARNINGS

**C13, C33** The terminals for separate flues must be fitted inside a 50 cm square. Detailed instructions are provided with the individual accessories.

**C53** Do not fit the flue and air duct terminals on opposite walls of the building.

**C63** The maximum pressure drop  $\Delta P$  of the ducts must not exceed the values indicated in table 1A. The ducts must be certified for this specific use and for a temperature in excess of 100°C. The flue terminal must be certified to EN 1856-1.

**C43, C83** The flue terminal or flue duct must be suitable for the purpose.



*For optimal installation, the accessories supplied by the manufacturer should be used.*

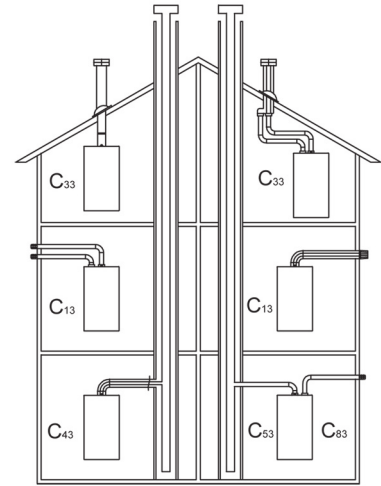

CG\_1638

**TABLE 1A**

If the flue and air ducts installed are not supplied by BAXI S.p.A., make sure they are certified for the type of use and have a maximum pressure drop as indicated in the table to the side.

	$\Delta P$ (Pa)
1.115 - 1.130	180
1.150	270



To optimise operating safety, make sure the flue ducts are firmly fixed to the wall with suitable brackets. The brackets must be positioned over the joints at a distance of approximately 1 metre from one another.



Make sure there is a minimum downward slope of 5 cm per metre of duct towards the boiler.



**SOME OUTLET DUCT INSTALLATION EXAMPLES AND THEIR RELATIVE MAXIMUM LENGTHS ARE SHOWN IN ANNEX "SECTION" D AT THE END OF THIS MANUAL.**

### 10.1 CONCENTRIC DUCTS

This type of duct is used to discharge exhaust fumes and draw combustion air both outside the building and if a LAS flue is fitted. The 90° coaxial bend allows the boiler to be connected to a flue-air duct in any direction as it can be rotated by 360°. It can also be used as a supplementary curve combined with a coaxial duct or a 45° curve.

If fumes are discharged outside the building, the flue-air duct must protrude at least 18 mm from the wall to allow an aluminium weathering surround to be fitted and sealed to avoid water infiltrations.

- A 90° bend reduces the total duct length by 1 metre.
- A 45° bend reduces the total duct length by 0.5 metres.
- The first 90° bend is not included when calculating the maximum available length.

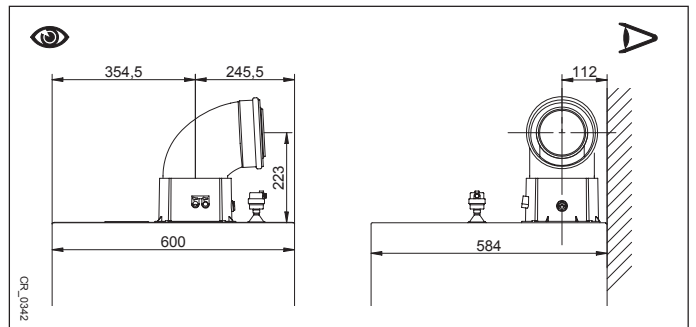

### 10.2 SEPARATE DUCTS

This type of installation makes it possible to discharge exhaust fumes both outside the building and into single flue ducts. Comburent air can be drawn in at a different location from that of the flue terminal. The accessory splitting kit comprises a flue duct adaptor  $\varnothing$  110 mm (B) and an air duct adaptor  $\varnothing$  110 mm (A). For the air duct adaptor, fit the screws and seals previously removed from the cap.

The 90° bend is used to connect the boiler to the inlet and outlet ducts, adapting them to various requirements. It can also be used as a supplementary curve combined with a duct or a 45° bend.

- A 90° bend reduces the total duct length by 0.5 metres.
- A 45° bend reduces the total duct length by 0.25 metres.
- The first 90° bend is not included when calculating the maximum available length.

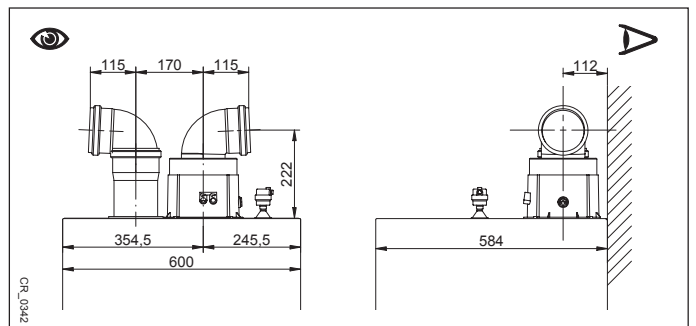

## 10.3 CASCADE FLUES

This type of duct evacuates the products of combustion of more than one boiler in a cascade connection through a shared fumes collector. The manifold has an incorporated clapet valve and must be used only to connect the boilers to the flue duct. The diameters available are: Ø160 mm and double diameter Ø160/250 mm. A range of accessories is available on request.

**TABLE 1B**

BOILER MODEL	MAXIMUM NUMBER OF BOILERS IN CASCADE CONNECTION		PARAMETER P60 Revs/min (rpm) at minimum Power	
	Ø 160 mm	Ø 160/250 mm	G20	G31
1.115 - 1.130	2	4	1850	2000
1.150	2	4	1850	2000

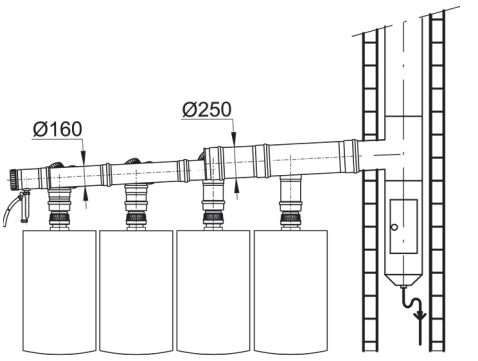

In this outlet typology, a fumes clapet valve (no-return valve), Ø 110/110 mm, must be fitted to each boiler. Change the parameter P60 as shown in table 1B following the procedure described in chapter 14.



The flue header size must be calculated by a qualified technician during the system design stage, as required by current regulations.

## 11. ELECTRICAL CONNECTIONS

This machine is only electrically safe if it is correctly connected to an efficient earth system in compliance with current safety regulations. Connect the boiler to a 230V single-phase earthed power supply using the supplied three-pin cable, observing correct Live-Neutral polarity.

**Use a double-pole switch with a contact separation of at least 3 mm.**

When replacing the power supply cable, fit a harmonised "HAR H05 VV-F" 3x0,75 mm<sup>2</sup> cable with a maximum diameter of 8 mm. To access the terminal block, remove the front boiler panel (fixed with two screws at the bottom), turn the control box downwards and access terminal blocks **M1**, **M2**, **M3**, used for the electrical connections, after removing the protective cover. The 3.15 A fast-blowing fuses are incorporated in the power supply terminal block (to check and/or replace the fuse, pull out the black fuse carrier).

SEE WIRING DIAGRAM IN ANNEX "SECTION" B AT THE END OF THIS MANUAL



Make sure that the overall rated power input of the accessories connected to the appliance is less than 2A. If it is higher, install a relay between the accessories and the electronic board.



The connections in terminal blocks M1- M3 are high voltage (230 V). Before making connections, make sure the appliance is disconnected from the power supply. Respect the input polarity on terminal block M1: L (LINE) - N (NEUTRAL).

### TERMINAL BLOCK M1

(L) = Live (brown)

(N) = Neutral (light blue).

⊕ = Earth (yellow-green).

(1) (2) = contact for Room Thermostat.



Put back the jumper on terminals 1-2 of boiler terminal block M1 if the room thermostat is not used or if the Remote Control, supplied as an accessory, is not installed.

### TERMINAL BLOCK M2

**Terminals 1 (back-lighting) - 2 (earth) - 3 (+12V):** connection to the Remote Control (low voltage) supplied as an accessory.

**Terminals 4 - 5 (common):** External Probe connection (supplied as an accessory)

**Terminals 6 - 5 (common):** 2nd Auxiliary Probe (probes for solar plant, cascade system, etc.).

**Terminals 7 - 5 (common):** 1st Auxiliary Probe (probes for solar plant, cascade system, etc.).

**Terminals 9-10:** storage boiler sensor connection.

**Terminal 8:** not used.

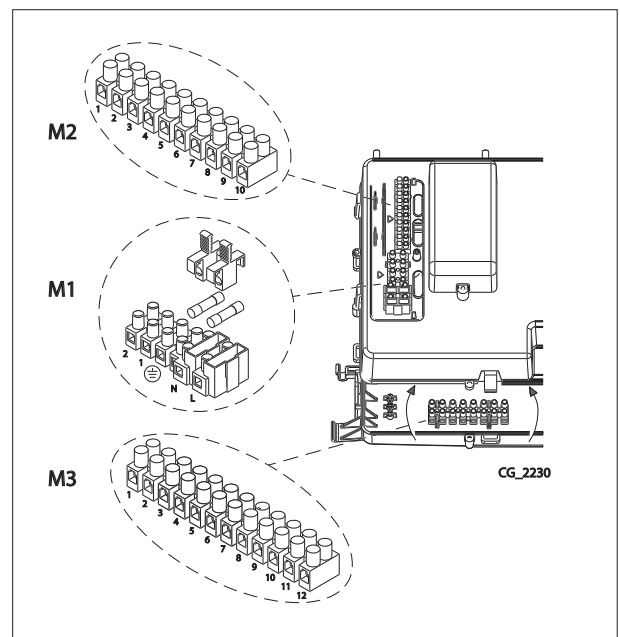

**TERMINAL BLOCK M3**

**Terminal 1-2:** (230Vac - max 1A) power supply of modulating boiler pump (PWM)

**Terminal 2-3:** (max 1A) power supply of non-modulating boiler pump (ON - OFF)

**Terminal 4:** not used

**Terminal 5-6:** PWM signal of the modulating pump

**Terminal 7-8:** not used

**Terminal 9 - 10:** Domestic Hot Water tank pump

**Terminal 11 - 12:** Heating System pump (device connected downstream of the hydraulic separator)



If the appliance is connected to an underfloor system, install a limit thermostat to prevent the latter from overheating.



Use the relative cable grommets at the bottom of the boiler to thread the cables through to the terminal blocks.



A 250Vac/250Vac relay with a minimum current rating of 16A and able to withstand a starting current of above 100A is required to connect the external pumps.

**11.1 CONNECTING THE ROOM THERMOSTAT**



The connections in terminal block M1 are high voltage (230 V). Before making connections, make sure the appliance is disconnected from the power supply. Respect polarity L (LIVE) - N (NEUTRAL).

To connect the Room Thermostat to the boiler, proceed as described below:

- Switch off the boiler;
- Access the terminal block M1;
- Remove the jumper from the ends of contacts 1-2 and connect the wires of the volt free Room Thermostat;
- Switch on the boiler and make sure the Room Thermostat works correctly.

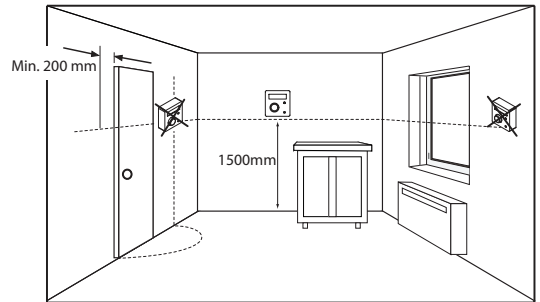

**11.2 ACCESSORIES NOT INCLUDED IN THE SUPPLY**

**11.2.1 REMOTE CONTROL**



The wire (1) from the boiler terminal block M2 powers the display backlighting (12 V). It is not necessary to connect this wire to make the Remote Control work.

To operate the boiler with the Remote Control mounted on the wall, purchase accessory A supplied with the base A1. Also see the mounting and operation instructions supplied with the kit A. Proceed as follows:

- Switch off the boiler.
- Pass the three wires from the boiler terminal block M2 through the hole in the base A1 to apply to the wall.
- Connect wires 1-2-3 of the boiler terminal block M2 to terminals (1)-(2)-(3) of the base terminal block A1 respectively.
- Fix the base A1 to the wall using the expansion grips and screws supplied with the accessory.
- Apply the Control Panel A to the base fixed to the wall, taking care not to apply excessive force.
- Power the boiler making sure that the Remote Control lights up.

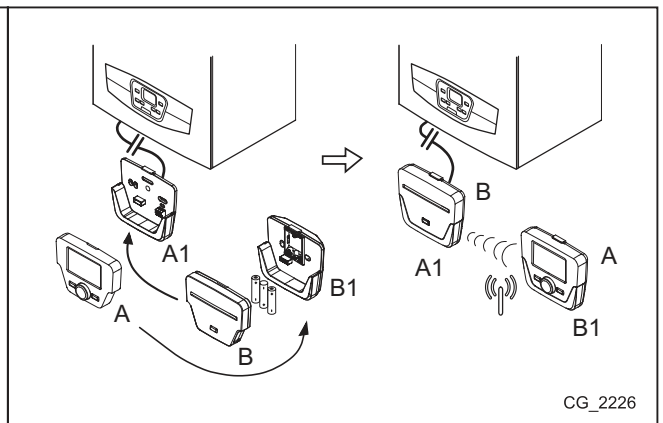
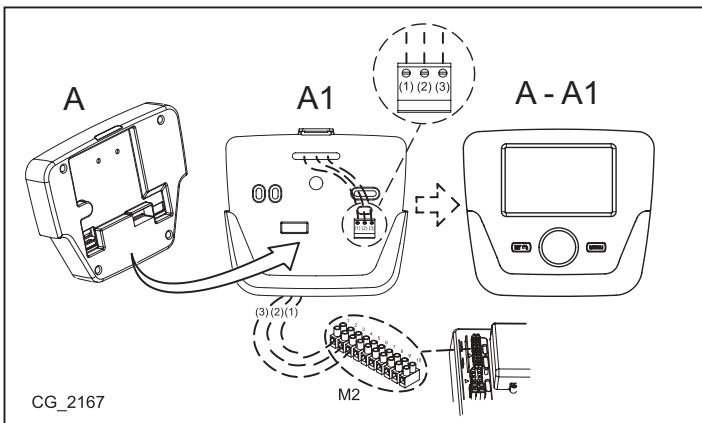

<b>A</b>	Control Panel	<b>A1</b>	Base for wall-mounted Control Panel
<b>B</b>	Led interface accessory	<b>B1</b>	Base for Led interface accessory
<b>(1)</b>	Display backlighting +12V	<b>(2)</b>	Earth connection
		<b>(3)</b>	Power input/Signal +12V



Use the Remote Control to set the programmable timer for heating and DHW. See the instructions supplied with the accessory.

## SETTING PARAMETERS USING THE REMOTE CONTROL

SYMBOLS FOR REMOTE CONTROL			
	Turn knob <b>B</b>		Display shows
	Press knob <b>B</b>		Press button <b>A</b> and knob <b>B</b> together
	Press button <b>A</b> or <b>C</b>		Press buttons <b>A</b> and <b>C</b> together

### KEY TO FIGURE MENU

<b>1</b>	Enduser	<b>3</b>	Engineer
<b>2</b>	Commissioning	<b>4</b>	OEM



**ALL MODIFIED PARAMETERS SHOULD BE NOTED DOWN IN THE TABLE AT THE END OF THIS MANUAL.**

The following procedure is used to access the four boiler programming menus:

- from the main menu **C**.
- **A** and **C** (hold down for approx. 6 seconds) **B** menu **1-2-3-4** (see figure to side and key).
- **C** to go back one menu at a time to the main menu.

When the Control Panel is wall-mounted enable the **room sensor** and **flow temperature modulation** as follows:

#### A) ROOM SENSOR

- Access menu **2**.
- **B** **Operator unit** **B** to confirm.
- **B** programme row **40** (Used as) **B**.
- **B** (anti-clockwise) **Room unit 1** **B** to confirm (the room sensor is now active).
- **C** to return to the previous menu then **B** **Configuration** **B**.
- **B** programme row **5977** (Function input H5) then **B** to confirm.
- **B** **None** **B** to confirm.



For correct operation of the environment unit during the reduced time band it is necessary to set the parameter 5977 = "none".

#### B) FLOW TEMPERATURE MODULATION

To set flow temperature modulation, disable parameter **742** (HC1). Proceed as follows:

- Access menu **2**.
- **B** **Temps / mode CH1** **B** to confirm **B** **742** (Flow temp setpoint room stat) **B** to confirm.
- **B** (anti-clockwise) "----" then **B** to confirm.



If, when turning the knob **B** on the main menu, the display visualises the boiler flow temperature instead of the ambient temperature, parameter 742 has not been set correctly.

After every system configuration (e.g.: solar combination, connection an external storage boiler, etc.) perform the following procedure to update the boiler board to the new configuration:

- Access menu **2** as indicated at the beginning of this section.
- **B** **Configuration** **B** **B** programme row **6200** then **B**.
- **B** **Yes** then **B** to confirm.

#### ZONE SYSTEM WITH INSTALLATION OF THE REMOTE CONTROL

The electrical connection and the adjustments required to manage a system divided into zones with use of the Remote Control differs according on the accessories connected to the boiler. To install and configure, see the instructions of the **Expansion Module** supplied as an accessory.

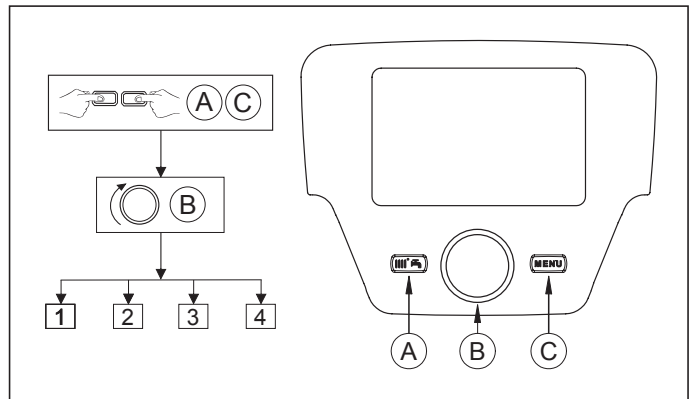

**ADJUSTING THE TEMPERATURE OF THE HIGH TEMPERATURE HEATING SYSTEM**



To avoid frequent starting and stopping, raise the minimum temperature setpoint of the boiler in the heating mode by setting parameters **740**, to not less than 45°C, using the procedure described in point **B**.

**TEMPERATURE ADJUSTMENT ON LOW TEMPERATURE HEATING SYSTEM**

For a low temperature system (such as underfloor heating), reduce the maximum CH temperature setpoint on the boiler by setting parameter **741** (point B) to a value not greater than 45°C.

**11.2.2 EXTERNAL SENSOR**

To connect this accessory, see figure to side (terminals **4-5**) and the instructions supplied with the sensor.

With the External Sensor connected,   on the boiler control panel move the set climate curve **Kt** in parallel (see annex "**SECTION**" **E** and parameter **P03** in the table in section 14). To increase room temperature press **+**, to decrease press **-**.

**SETTING THE "Kt" CLIMATE CURVE**

To set the required kt climate curve, proceed as follows:

- Access the menu as described in section 14.
- Select parameter **P03**.
- Select the climate curve from among those available, see the curve chart in annex "**SECTION**" **E** at the end of this manual (the preset curve is 1.5).

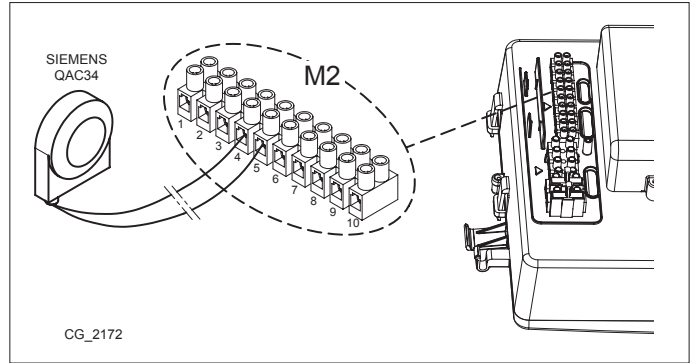

**KEY TO CURVE CHART Kt - "SECTION" E**

	Flow temp		Outside temp
---	-----------	---	--------------

**11.2.3 HEATING SYSTEM PUMP**

Install the system pump downline from the hydraulic separator. Choose the pump according to the required system capacity/head characteristics (see annex "**SECTION**" **F**).

 **A 250Vac/250Vac relay with a minimum current rating of 16A and able to withstand a starting current of above 100A is required to connect the external pumps.**

**11.2.4 EXTERNAL STORAGE BOILER**

The boiler can be electrically connected to an external storage boiler. A diagram of the hydraulic connection of the external storage boiler is shown in annex "**SECTION**" **F**. Connect the storage boiler pump to terminals **9-10** of the **M3** terminal block (see annex "**SECTION**" **B**). Install the storage boiler downline from the hydraulic separator. Use the sensor supplied as an accessory and connect it to terminals **9-10** of terminal block **M2** (see annex "**SECTION**" **B**). Make sure that the exchange capacity of the storage boiler coil is appropriate for the power of the boiler.

 **A 250Vac/250Vac relay with a minimum current rating of 16A and able to withstand a starting current of above 100A is required to connect the external pumps.**

**EXTERNAL SYSTEM MANAGEMENT MODULES**

The boiler can independently manage up to three heating circuits by using external accessories such as room units, remote controls and external modules (AGU 2.550, AVS 75.391 and AVS 75.370). The boiler electronics also comprises a wide range of functions for personalising and managing various system types. To assure correct system operation, a number (from 1 to 3) must be assigned to each accessory in order to allow the boiler board to recognise it. Consequently, carefully read the instructions provided with the accessories. The external module AVS 75.370 can be used to control modulation of 2 pumps: a zone pump and/or the storage boiler pump.

**11.2.5 MIXED ZONES ("SECTION" F)**

A mixed zone can be managed using the **AVS75** external module, supplied as an accessory. This accessory can manage: a zone pump, a mixing valve, a temperature sensor, a limit thermostat and a room thermostat. To connect the components and adjust the system read the manual provided with the accessory.

**11.2.6 BOILERS IN A CASCADE CONNECTION ("SECTION" F)**

The **AVS75** external unit, supplied as an accessory, is used to manage a heating system with up to 16 boilers connected in a cascade arrangement and a possible separate storage boiler providing domestic hot water. This accessory, connected to one of the cascade boilers, can directly control the circuit components up to a maximum of 3 independent relay outlets, 2 temperature sensors, 1 high voltage limit thermostat connector and one 1 control input (e.g.: room thermostat). The system also requires an **OCI 345** interface on each boiler comprising in the cascade arrangement. To adjust boiler parameters see section "PARAMETER SETTINGS". To connect the components and adjust the system read the manual provided with the accessory.

**11.2.7 SOLAR PLANT ("SECTION" F)**

Use the **AGU 2.550** external unit, supplied as an accessory, to manage a solar plant. To connect the plant, see the instructions supplied with the accessory.

 **THE HYDRAULIC DIAGRAMS OF THE CASES DESCRIBED CAN BE CONSULTED IN ANNEX "SECTION" F AT THE END OF THIS MANUAL**



## 12. INITIAL IGNITION - SPECIAL FUNCTIONS

When the boiler is powered up, the code "311" appears on the display and the boiler is ready for "initial ignition". Follow the procedure "GAS EXTRACTION FUNCTION" as described in the section below and enable programme 312. After this operation, the boiler is ready to ignite the burner.



During this phase it is recommended to keep the pressure in the system at a value between 1 and 1.5 bar.

### 12.1 SYSTEM GAS EXTRACTION FUNCTION

This function is used to facilitate the elimination of the air inside the heating circuit when the boiler is first installed or after maintenance when the water is drained from the primary circuit.

To enable the system gas extraction function press buttons **iip** **mir-** together for 6 seconds. When the function is active, **On** appears on the display for a few seconds, followed by programme row **312**.

The electronic board will activate a pump on/off cycle lasting 10 minutes. The function will automatically stop at the end of the cycle. To manually exit this function, press the above buttons together for 6 seconds once again.

### 12.2 CALIBRATION FUNCTION

To calibrate the gas valve, proceed as follows:

- Press buttons **mir+** and **iip** together for at least 6 seconds. When the function is enabled, the displays shows "On" for a few seconds followed by programme row "304" alternated with the % of boiler power.
- Press **mir+** **mir-** to gradually adjust power (sensitivity 1%).
- To exit press both buttons together for at least 6 seconds, as described in point one



Press **ovr** to display the instantaneous flow temperature for 15 seconds.

### 12.3 CHIMNEY SWEEPER

When this function is enabled, the boiler generates maximum heating power. To enable the function, proceed as follows:

- press **mir-** **ovr** together for 6 seconds. The display shows "303" alternated with the power output of the boiler.
- Press **mir-** and **mir+** to adjust boiler power **1**=minimum, **2**=maximum DHW, **3**=maximum heating.
- To interrupt the function repeat the procedure described in point one.

## 13. FAULTS THAT CANNOT BE RESET BY THE USER

In case of **FAULTS** that cannot be reset by pressing **ovr** (such as E151, E162 or exceeding 5 manual RESET attempts by the user) RESET the board by pressing the black button (**R**) located under the rubber cap (symbol ) of the front control panel (figure to side).

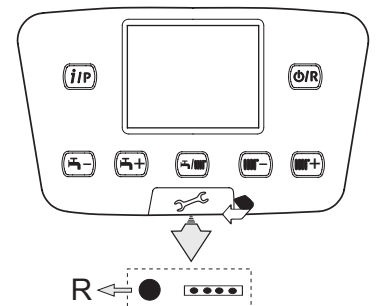

# 14.PARAMETERS SETTING

To programme the parameters of the boiler electronic board, proceed as follows:

- Press together and hold them down for 6 seconds until programme row "P02" appears on the display alternated with the set value (°C);
- Press and hold down for 6 seconds until "On" appears on the display. Release the button and "P01" appears on the display;
- Press to scroll the list of parameters;
- Press , the value of the selected begins flashing, press to change the value;
- press to confirm the value or press to exit without saving.



Further information concerning the parameters listed in the following table are supplied together with the required accessories.

(a)	(b)	ZONE 1 HEATING PARAMETERS (main zone)		Factory setting	Minimum	Maximum
P01	700	*Operating mode (0=Frost Protection, 1=Timed, 3=T.comfort)	-	3	0	3
P02	712	*Reduced ambient temperature	°C	16	4	35
P03	720	**Kt" curve slope	-	1,5	0,1	4
P04	721	**Kt" curve drift	-	0	- 4,5	4,5
P05	726	**Kt" curve adaptation (0=off)	-	1	0	1
P06	740	Flow temperature setpoint (minimum value)	°C	25	8	80
P07	741	Flow temperature setpoint (maximum value)	°C	80	25	80
P08	742	*Enable modulating temperature if set = "---"	°C	80	25	80
P09	750	*Room influence ("---" = disabled)	%	50	1	100
P10	834	*Opening/Closing speed of mix valve	S	30	30	873

### ZONE2 HEATING PARAMETERS (with accessory Expansion Unit)

P11	1000	*Operating mode (0= Frost Protection, 1=Timed, 3=T.comfort)	°C	3	0	3
P12	1010	*Comfort room temperature	°C	20	4	35
P13	1012	*Reduced room temperature	°C	16	4	35
P14	1020	**Kt" curve slope	-	1,5	0,1	4
P15	1021	**Kt" curve drift	-	0	- 4,5	4,5
P16	1026	**Kt" curve adaptation (0=off)	-	1	0	1
P17	1040	Flow temperature setpoint (minimum value)	°C	25	8	80
P18	1041	Flow temperature setpoint (maximum value)	°C	80	25	80
P19	1042	*Enable modulating temperature if set = "---" (flow temp. setpoint if P63=0)	°C	80	25	80
P20	1050	*Room influence ("---" = disabled)	%	50	1	100
P21	1134	*Opening/Closing speed of mix valve	s	30	30	873

### DHW PARAMETERS

P22	1620	Operating mode in DHW (with Remote Control) 0=always enabled, 1=according to hourly heating programme, 2= according to hourly DHW programme.	-	2	0	2
P23	1640	Anti-legionella function Disabled 0=disabled, 1=periodic (depending on P24)	-	0	0	1
P24	1641	Periodic anti-legionella function enable (only if P23 =1) 1=daily, 2..6=intervals of 2..6 days, 7=once a week	-	7	1	7
P25	1663	Circulation temperature setpoint (additional DHW pump)	°C	45	8	80
P26	5470	Preheating time for DHW circuit (1=10' -- 144=1440')	min	0	0	144

### BOILER PARAMETERS

P27	2243	Minimum boiler off time	min	3	0	20
P28	2217	Frost Protection setpoint	°C	5	-20	20
P29	2250	Pump post-circulation time	min	3	0	240
P30	2441	Max. fan speed (heating)	rpm	xxx	0	8000
P31	2455	Minimum boiler off differential	°C	5	0	20
P32	2720	Not used (Do NOT change this parameter)	-	0	0	1
P33	2721	Not used (Do NOT change this parameter)	-	1	1	2

### SOLAR PLANT PARAMETERS (with accessory Expansion Unit)

P34	3810	Temperature - on differential	°C	8	0	40
P35	3811	Temperature - off differential	°C	4	0	40
P36	3830	Pump start function ("---" = disabled)	min	---	5	60
P37	3850	Solar panel manifold overheating protection ("---" = disabled)	°C	---	30	350
P38	5050	DHW boiler tank charging temperature max	°C	65	8	95
P39	5051	Maximum temperature of storage tank	°C	90	8	95



**CONFIGURATION**

<b>P40</b>	<b>5700</b>	Not used (Do NOT change this parameter)	-	---	---	---
<b>P41</b>	<b>5710</b>	Zone 1 heating circuit (1=enabled)	-	<b>1</b>	0	1
<b>P42</b>	<b>5715</b>	Zone 2 heating circuit (1=enabled)	-	<b>0</b>	0	1
<b>P43</b>	<b>5730</b>	DHW sensor (1=Tank sensor, 2=Thermostat, 3=instantaneous sensor)		<b>1</b>	1	3
<b>P44</b>	<b>5890</b>	Not used (Do NOT change this parameter)	-	<b>33</b>	0	43
<b>P45</b>	<b>5931</b>	*BX2 sensor input (first auxiliary sensor – section 11)	-	<b>0</b>	0	19
<b>P46</b>	<b>5932</b>	*BX3 sensor input (second auxiliary sensor – section 11)	-	<b>0</b>	0	19
<b>P47</b>	<b>5977</b>	*Input H5 (multifunction input – 18=Room thermostat)	-	<b>18</b>	0	32
<b>P48</b>	<b>6020</b>	*Configuration of accessory Expansion Unit	-	<b>0</b>	0	7
<b>P49</b>	<b>6024</b>	Input EX21 module 1 (configuration of HC Safety Thermostat)	-	<b>0</b>	0	1
<b>P50</b>	<b>6046</b>	Input H2 module 1 (multifunction input)	-	<b>0</b>	0	58

<b>P51</b>	<b>6097</b>	Sensor type collector (1= NTC, 2= Pt 1000)	-	<b>2</b>	1	2
<b>P52</b>	<b>6110</b>	Building time constant (depending on the insulations of the building)	h	<b>15</b>	0	50
<b>P53</b>	<b>6220</b>	Software version	-	---	0	99
<b>P54</b>	<b>6600</b>	LPB device address (BUS connection)	-		1	16
<b>P55</b>	<b>6601</b>	LPB segment address (BUS connection)	-		0	14
<b>P56</b>	<b>6640</b>	Clock time source	-		0	3

**MAINTENANCE**

<b>P57</b>	<b>7045</b>	Time after maintenance	month	<b>xxx</b>	0	240
<b>P58</b>	<b>6704</b>	View/Hide secondary fault internal code (0=no)	-	<b>1</b>	0	1

**BURNER CONTROL**

<b>P59</b>	<b>9512</b>	Required ignition speed	rpm	<b>xxx</b>	0	8000
<b>P60</b>	<b>9524</b>	Required minimum operating speed (low speed)	rpm	<b>xxx</b>	0	8000
<b>P61</b>	<b>9529</b>	Required maximum operating speed (high speed)	rpm	<b>xxx</b>	0	8000

**BOILER CONTROL PANEL PARAMETERS**

<b>P62</b>	-	Unit of measurement (1=bar, °C – 2=PSI, °F)	-	<b>1</b>	1	2
<b>P63</b>	-	Control panel operation: (1=central, 0=local)	-	<b>1</b>	0	1
<b>P64</b>	-	Software version	-	<b>xx</b>	0	999

\* see "Accessories not included in supply"

**xx**: the value depends on the software version      **xxx**: the value depends on the type of boiler

**(a)**: parameters read on the front boiler panel (fixed control panel)      **(b)**: parameters read on the Remote Control

## 15. GAS VALVE CALIBRATION

To calibrate the gas valve, enable the calibration function as described in section 12.2 and carry out the following operations:

### 1) Calibrating MAXIMUM heat output.

Check that the  $CO_2/O_2$  measured on the flue duct, with the boiler operating at maximum heat capacity, matches that indicated in table 1C. If it does not, remove the threaded cap on the gas valve and turn the adjustment screw (V). Turn the screw clockwise to decrease the level of  $CO_2$  and anti-clockwise to increase it.

### 2) Calibrating REDUCED heat output

Check that the  $CO_2/O_2$  measured on the flue duct, with the boiler operating at minimum heat capacity, matches that indicated in table 1C. If it does not, remove the threaded cap on the gas valve and turn the adjustment screw (K). Turn the screw clockwise to increase the level of  $CO_2$  and anticlockwise to decrease it.

<b>V</b>	Gas flow adjustment screw	<b>Pi</b>	Gas supply pressure tap
<b>K</b>	OFFSET adjustment screw		

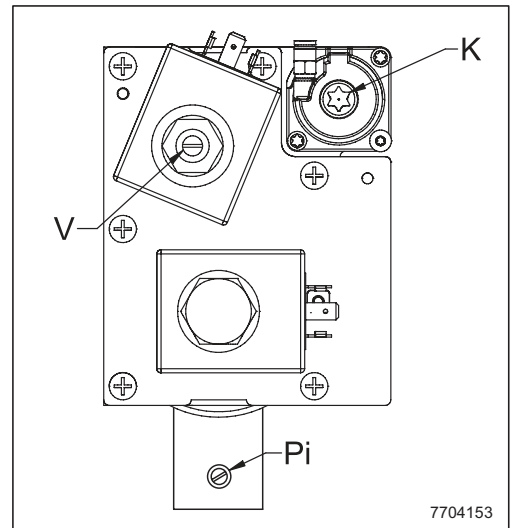

For each  $CO_2/O_2$  value found at the maximum thermal capacity, there is a range of  $CO_2/O_2$  values at the minimum thermal capacity shown in the same line of the table.

The nominal calibration values of the gas valve for each type of gas used are shown in bold.

The  $CO_2/O_2$  values are with the cover closed.

The maximum permitted CO value must be lower than 250 ppm.

TABLE 1C

G20				G31			
CO <sub>2</sub> (%)		O <sub>2</sub> (%)		CO <sub>2</sub> (%)		O <sub>2</sub> (%)	
P max	P min	P max	P min	P max	P min	P max	P min
9,7	8,8+9,2	3,6	4,5+5,2	10,5	10+10,4	4,9	5,1+5,7
9,6	8,7+9,1	3,8	4,7+5,4	10,4	9,9+10,3	5,1	5,2+5,8
9,5	8,6+9	3,9	4,8+5,6	10,3	9,8+10,2	5,2	5,4+6
9,4	8,5+8,9	4,1	5+5,7	10,2	9,7+10,1	5,4	5,5+6,1
9,3	8,4+8,8	4,3	5,2+5,9	10,1	9,6+10	5,5	5,7+6,3
<b>9,2</b>	<b>8,3+8,7</b>	<b>4,5</b>	<b>5,4+6,1</b>	<b>10</b>	<b>9,5+9,9</b>	<b>5,7</b>	<b>5,8+6,4</b>
9,1	8,2+8,6	4,7	5,6+6,3	9,9	9,4+9,8	5,8	6+6,6
9	8,1+8,5	4,8	5,7+6,5	9,8	9,3+9,7	6,0	6,1+6,7
8,9	8+8,4	5	5,9+6,6	9,7	9,2+9,6	6,1	6,3+6,9
8,8	7,9+8,3	5,2	6,1+6,8	9,6	9,1+9,5	6,3	6,4+7,1
8,7	7,8+8,2	5,4	6,3+7	9,5	9+9,4	6,4	6,6+7,2

## 15.1 GAS CONVERSION

**!** To convert operation with methane gas (G20) to operation with propane gas (LPG), first replace the nozzle (A) as shown in the figure and then calibrate the gas valve as described above. Afterwards, make sure there are no gas leaks. Modify the parameters (fan rpm) as indicated in table 2 following the procedure described in section 14.

TABLE 2

Boiler model	PARAMETERS - rpm					GAS NOZZLE Ø (mm)	
	P60*		P30 - P61 *	P59*			
	Min. power	Max. power	Ignition power	G20	G31	G20	G31
<b>1.115</b>	1550	1950	5150	2500	2700	12	11
<b>1.130</b>	1550	1950	5800	2500	2700	12	11
<b>1.150</b>	1800	2000	6900	2500	2700	12	11

\* value read on the boiler front panel display to multiply x 10 (e.g.: 150 corresponds to 1500 rpm)

**i** To simplify calibration of the gas valve, set the "calibration function" directly on the boiler control panel as described in section 12.2.

**ii** For cascade ducts, change the parameter P60 (see table 1B in chapter 10.3).

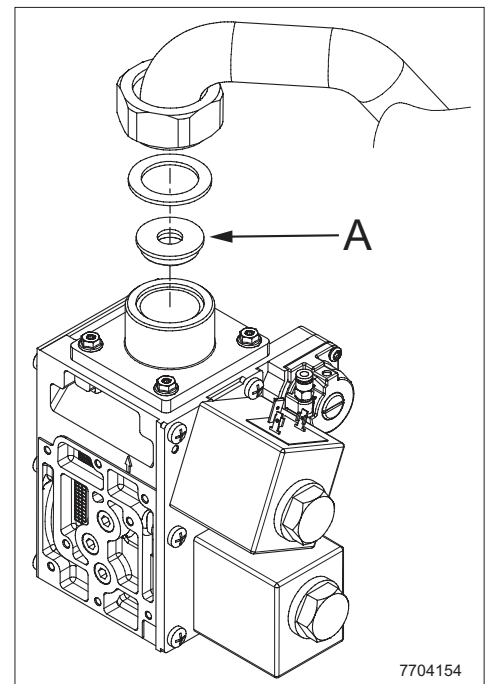

## 16. ADJUSTMENT AND SAFETY DEVICES

The boiler has been designed in full compliance with European reference standards and in particular is equipped with the following:

- **Limit thermostat**

Thanks to a sensor placed on the CH flow line, this thermostat interrupts the flow of gas to the burner if the water in the primary circuit overheats. Under such conditions the boiler is blocked and only after the fault has been eliminated can it be ignited again by pressing .

- **Exchanger flange thermostat (260°C)**

This device is located on the exchanger flange and interrupts the flow of gas to the burner if the front insulation yields and overheats the exchanger or the flange gasket develops a fault. Press the reset button on the thermostat, eliminate the fault and then press the reset button on the boiler control panel.

- **Thermal fuse**

This device is located at the rear of the exchanger and interrupts the flow of gas to the burner if the rear insulation yields and overheats the exchanger. If this device cuts in, dismantle the exchanger and replace the thermal fuse (see paragraph "THERMAL FUSE REPLACEMENT OF HEAT EXCHANGER").



It is forbidden to disable this safety device.

- **NTC flue sensor**

This device is positioned on the fumes duct. The electronic board stops gas from flowing to the burner in case of over heating. Press  to re-establish normal operating conditions.



The above reset operation is only possible if the temperature is less than 90°C.



It is forbidden to disable this safety device

- **Fumes pressure switch**

This device stops the flow of gas to the burner when the pressure in the flue ducts exceeds 600 Pa. Under these conditions, the boiler is blocked and only after the fault has been eliminated can the boiler be ignited again (see section "FAULTS THAT CANNOT BE RESET BY THE USER").

- **Flame ionisation detector**

The flame sensing electrode guarantees safety of operation in case of gas failure or incomplete ignition of the main burner. In these conditions, the boiler blocks. Press  to re-establish normal operating conditions.

- **Hydraulic pressure switch**

This device allows the main burner to be ignited only if system pressure is higher than 1 bars.

- **Pump post-circulation**

The electronically-controlled pump post-circulation function lasts 3 minutes and is enabled, in the heating mode, if the ambient thermostat causes the main burner to go out.

- **Antifreeze device**

The electronic boiler management system includes an "antifreeze" function for the heating and DHW systems which, when flow temperature falls below 5°C, operates the burner until a flow temperature of 30°C is reached. This function is enabled when the boiler is switched on, the gas supply is open and the system is correctly pressurised.

- **Pump anti-block function**

If no heat demand is received in the heating and/or DHW modes for 24 consecutive hours, the pumps will automatically start and operate for 10 seconds.

- **Hydraulic safety valve (heating circuit)**

This device is set to 6 bar and is used for the heating circuit. Connect the safety valve to a drain trap. Do not use it to drain the heating circuit.

- **Heating pump pre-circulation**

In case of a heat demand in the heating mode, the appliance can pre-circulate the pump before the burner is ignited. This pre-circulation phase last from a few seconds to a few minutes, depending on the operating temperature and installation conditions.

**The functions performed by the adjustment and safety devices are only operative if the boiler is switched on.**

## 17. PUMP CAPACITY/ HEAD

The hydraulic pump is modulating and circulates the water between the boiler and the hydraulic separator.

KEY TO PUMP CHARTS - "SECTION" E

Q	RATE OF FLOW
H	HEAD



THE PUMP FLOW / HEAD CHARTS CAN BE CONSULTED IN ANNEX "SECTION" E AT THE END OF THE MANUAL.

## 18. ANNUAL SERVICING

The service must be performed only by qualified and competent staff in accordance with the Gas safety, Installation and use regulations. In UK this person need to be approved by the Health and Safety Executive. To optimise boiler efficiency, carry out the following at the annual service:

- Check the appearance and airtightness of the gaskets of the gas and combustion circuits. Replace any worn seals with new original spares;
- Check the state and correct position of the ignition and flame-sensing electrodes;
- Check the state of the burner and make sure it is firmly fixed;
- Check for any impurities inside the combustion chamber. Use a vacuum cleaner to do this;
- Check the gas valve is correctly calibrated;
- Check the pressure of the heating system;
- Check the pressure of the expansion vessel (system);
- Check the fan works correctly;
- Make sure the flue and air ducts are unobstructed;
- Check for any blockages inside the siphon;
- Check correct operation of the fumes pressure switch, where present. Blow into the positive connector of the pressure switch without using electromechanical devices, until you hear the activation click.

**⚠ Before commencing any maintenance operations, make sure the boiler is disconnected from the power supply. After servicing, reset the original operating parameters of the boiler if they were changed.**

### 18.1 CLEANING THE CONDESATE TRAP

Unscrew the lower section of the water condense trap "A".

- Clean the bottom of the trap by flushing it out with water.
- Fill the lower section with water until about 10 mm below the upper edge.
- Fasten the lower section onto the condense trap again.

**⚠ Do not operate the boiler with empty condense trap to avoid risk of poisoning through the gas combustions.**

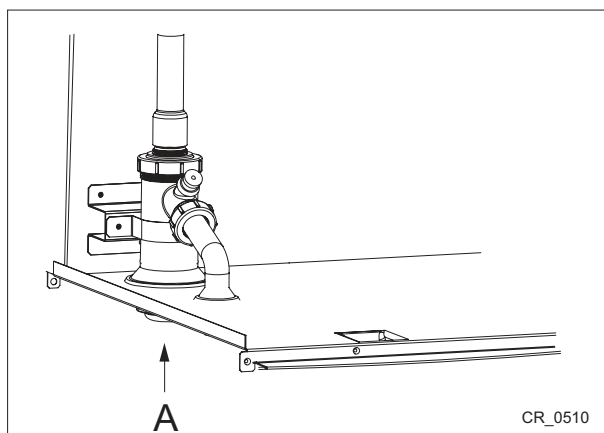

### 18.2 CLEANING THE HEAT EXCHANGER FUMES SIDE

**⚠ Before starting to clean the heat exchanger, wait until the temperature is lower than 40°C and protect all the electric components against splashes of water.**

Proceed as follows to clean the heat exchanger:

- Disconnect the boiler from the mains power supply.
- Close the gas inlet valve.
- Remove the front cover from the boiler.
- Lower the electrical box, ensuring it is protected against contact with water.
- Disconnect the cables of the ignition electrode, the flame sensing electrode, and the heat exchanger flange thermostat.
- Remove the fan-mixer-burner-flange assembly, unscrewing the 6 nuts M6 and the connector under the mixer.
- Protect the rear insulating panel (2) against water with a waterproof film, available in the cleaning kit.
- Accurately suck up the residue inside the combustion chamber and remove any scale, using a brush with plastic bristles available in the cleaning kit.
- Sprinkle the surfaces to be cleaned (1) generously with the appropriate liquid BX-HT Cleaner or similar using the appropriate spray bottle and wait 10 minutes (other products may be used, after consulting the authorised technical assistance service). Brush without rinsing and apply BX-HT Cleaner again. Let 10 more minutes pass, then brush again. If the result is not satisfactory, repeat the operation.
- When cleaning is finished, rinse with water.
- Replace the gasket of the burner support flange.
- To reassemble, proceed in the inverse order, tightening the 6 nuts of the flange with a torque of 5.5 Nm.

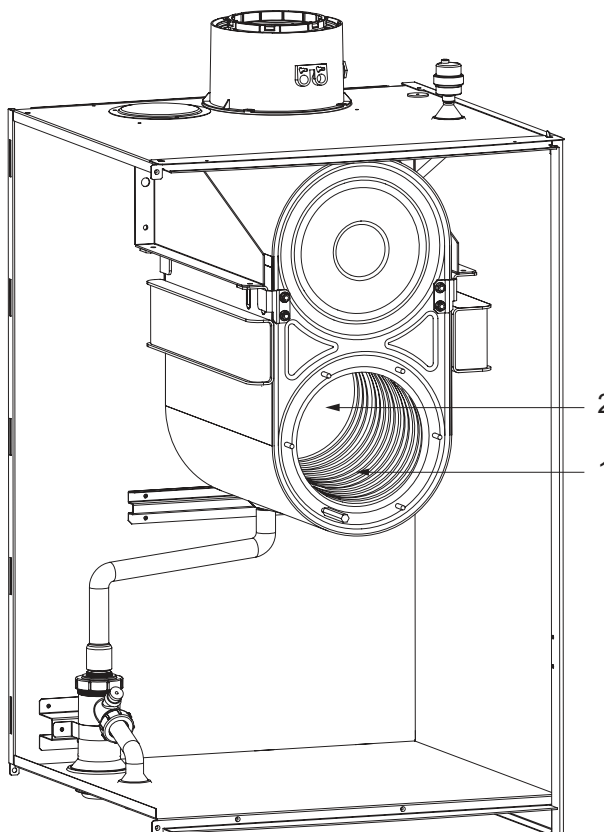

### 18.3 CHECKING THE BURNER

The burner needs no cleaning.

- Check the burner surface for damage, replace the burner if necessary.
- Check the positioning of the flame detection probe.
- Verify that the distance of the ignition electrode is within tolerance as shown in the figure.
- Check that the insulation of the burner flange it is not damaged otherwise replace it.

### POSITIONING THE ELECTRODES

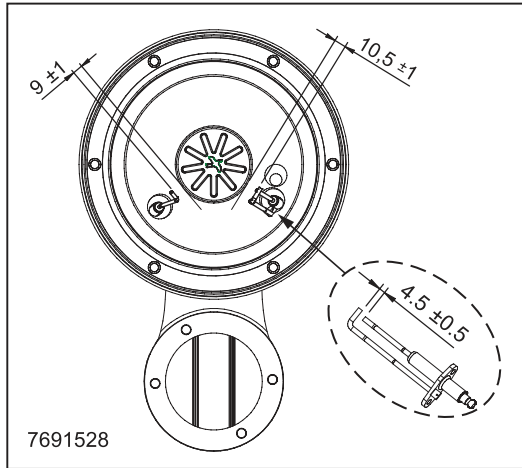

a	Flame detection probe
b	Ignition electrode
c	Burner
d	Burner surface insulation

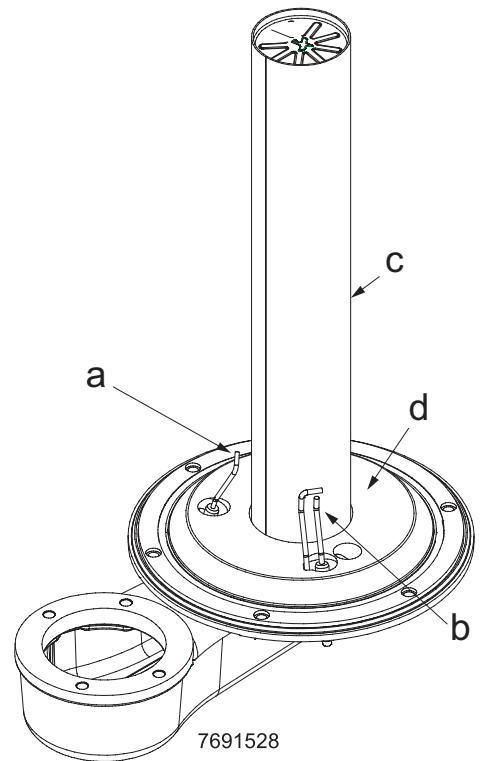

### 18.4 COMBUSTION PARAMETERS

To measure combustion efficiency and the toxicity of the products of combustion, the boiler is fitted with two dedicated test points. One connection point is connected to the flue gas discharge circuit ( **A** ), and allows monitoring of the quality of the combustion products and the combustion efficiency. The other is connected to the combustion air intake circuit ( **B** ), allowing checking of any recycling of the combustion products in case of coaxial pipelines. The following parameters can be measured at the connection point on the flue gas circuit:

- temperature of the combustion products;
- oxygen **O2** or carbon dioxide **CO2** concentration,
- carbon monoxide **CO** concentration.

The temperature of the comburent air must be measured on the test point located on the air intake flue ( **B** ) by inserting the measurement sensor by about 9 cm ( **C** ).



To enable the "CHIMNEY SWEEPER" consult section 12.3.

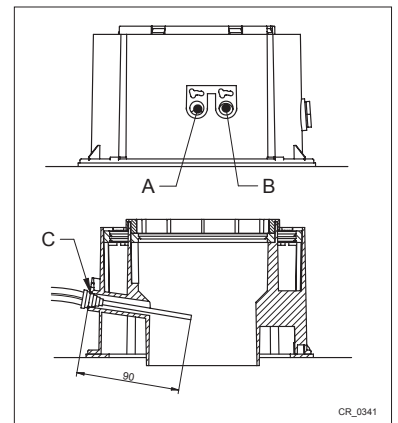

INSTALLER Section (en)

## 19.THERMAL FUSE REPLACEMENT OF HEAT EXCHANGER

The thermal fuse is positioned on the rear of the heat exchanger as shown in the figure, is electrically connected in series with the safety thermostat. Its function is to protect the exchanger from overheating in case of insulation failure. When this occurs the device appears on the display the anomaly **E110**. If the cause is due to the rupture of the isolation it is necessary to remove the heat exchanger and replace the rear isolation and the thermal fuse.

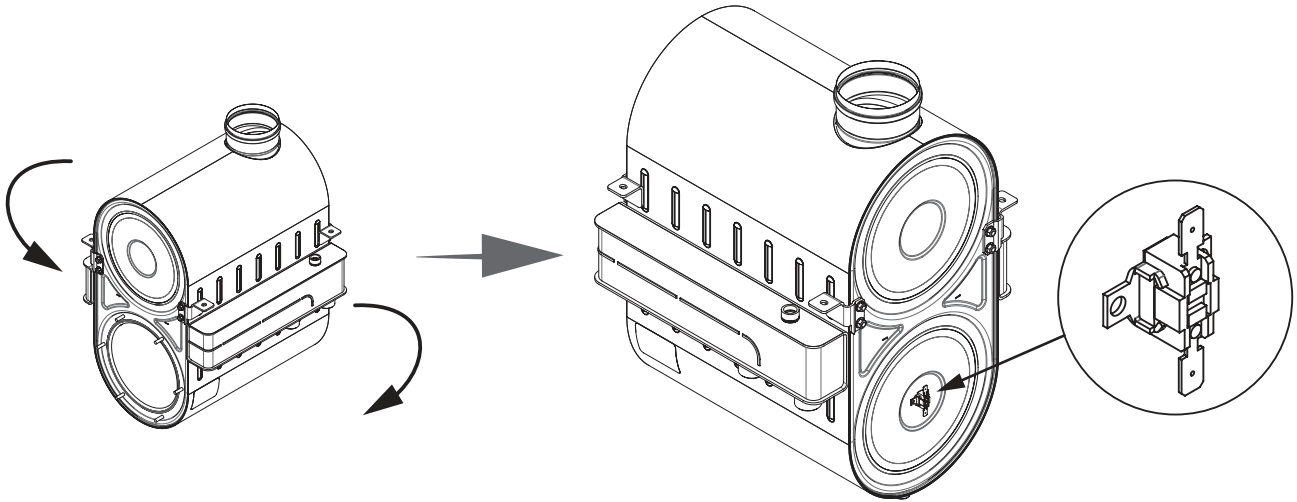

## 20.DISMANTLING, DISPOSAL AND RECYCLING



Only qualified technicians are authorised to service the device and system.

Before dismantling the appliance, be sure to disconnect the power supply, close the gas inlet shutoff valve and secure all of the boiler and system connections.

Dispose of the appliance correctly according to the laws and regulations in place. The appliance and accessories cannot be discarded along with normal household waste.

More than 90% of the materials that make up the appliance are recyclable.

## 21. TECHNICAL SPECIFICATIONS

Model: LUNA DUO-TEC MP+		1.115	1.130	1.150
Cat.		II <sub>2H3P</sub>		
Gas used	-	G20 - G31		
Rated heat input	kW	115,0	123,8	143,0
Reduced heat input (G20)	kW	24,8	24,8	28,6
Reduced heat input (G31)	kW	35,4	35,4	40,9
Rated heat power 80/60 °C	kW	112,8	121,5	140,3
Rated heat power 50/30 °C	kW	121,4	130,6	150,9
Reduced heat output 80/60 °C (G20)	kW	24,3	24,3	28,1
Reduced heat output 80/60 °C (G31)	kW	34,7	34,7	40,0
Reduced heat output 50/30 °C (G20)	kW	26,2	26,2	30,2
Reduced heat output 50/30 °C (G31)	kW	37,3	37,3	43,1
Rated efficiency 50/30 °C	%	105,5	105,5	105,5
Max. pressure of water in heating circuit	bar	6		
Min. pressure of water in heating circuit	bar	0,8		
Capacity of boiler circuit (volume of water)	l	10	10	11
Temperature range in heating circuit	°C	25÷80		
Fumes typology	-	C13 - C33 - C43 - C53 - C63 - C83 - C93 - B23		
Coaxial flue duct diameter	mm	110/160		
Diameter of separate outlets	mm	110/110		
Max. mass flow rate of fumes (G20)	kg/s	0,052	0,056	0,064
Min. mass flow rate of fumes (G20)	kg/s	0,012	0,012	0,014
Max. temperature of fumes	°C	70		
NOx Class	-	6		
Natural gas supply pressure 2H	mbar	20		
Propane gas supply pressure 3P	mbar	37		
Power supply voltage	V	230		
Power supply frequency	Hz	50		
Rated power supply	W	325	360	460
Net weight	kg	93	93	96
Dimensions - height	mm	952		
- width	mm	600		
- depth	mm	584		
Protection-limit against humidity (EN 60529)	-	IPX5D		
CE Certificate Nr.		0085CM0128		

### CONSUMPTION AT HEAT INPUT Q<sub>max</sub> and Q<sub>min</sub>

Q <sub>max</sub> (G20) - 2H	m <sup>3</sup> /h	12,16	13,09	15,12
Q <sub>min</sub> (G20) - 2H	m <sup>3</sup> /h	2,62	2,62	3,02
Q <sub>max</sub> (G31) - 3P	kg/h	8,93	9,62	11,11
Q <sub>min</sub> (G31) - 3P	kg/h	1,93	1,93	2,22



## 22. TECHNICAL PARAMETERS

BAXI LUNA DUO-TEC MP+			1.115	1.130	1.150
Condensing boiler			Yes	Yes	Yes
Low-temperature boiler <sup>(1)</sup>			No	No	No
B1 boiler			No	No	No
Cogeneration space heater			No	No	No
Combination heater			No	No	No
<b>Rated heat output</b>	<i>P<sub>rated</sub></i>	kW	113	122	140
Useful heat output at rated heat output and high temperature regime <sup>(2)</sup>	<i>P<sub>4</sub></i>	kW	112.8	121.5	140.3
Useful heat output at 30% of rated heat output and low temperature regime <sup>(1)</sup>	<i>P<sub>1</sub></i>	kW	37.5	40.4	46.6
<b>Seasonal space heating energy efficiency</b>	<i>η<sub>s</sub></i>	%			
Useful efficiency at rated heat output and high temperature regime <sup>(2)</sup>	<i>η<sub>4</sub></i>	%	88.4	88.4	88.4
Useful efficiency at 30% of rated heat output and low temperature regime <sup>(1)</sup>	<i>η<sub>1</sub></i>	%	97.8	97.8	97.8
<b>Auxiliary electricity consumption</b>					
Full load	<i>el<sub>max</sub></i>	kW	0.172	0.187	0.283
Part load	<i>el<sub>min</sub></i>	kW	0.051	0.051	0.052
Standby mode	<i>P<sub>SB</sub></i>	kW	0.003	0.003	0.003
<b>Other items</b>					
Standby heat loss	<i>P<sub>stby</sub></i>	kW	0.097	0.097	0.097
Ignition burner power consumption	<i>P<sub>ign</sub></i>	kW	0.000	0.000	0.000
Annual energy consumption	<i>Q<sub>HE</sub></i>	GJ			
Sound power level, indoors	<i>L<sub>WA</sub></i>	dB	58	60	64
Emissions of nitrogen oxides	NO <sub>x</sub>	mg/kWh	17	17	23
<b>Domestic hot water parameters</b>					
<b>Declared load profile</b>					
Daily electricity consumption	<i>Q<sub>elec</sub></i>	kWh			
Annual electricity consumption	<i>AEC</i>	kWh			
<b>Water heating energy efficiency</b>	<i>η<sub>wh</sub></i>	%			
Daily fuel consumption	<i>Q<sub>fuel</sub></i>	kWh			
Annual fuel consumption	<i>AFC</i>	GJ			
(1) Low temperature means for condensing boilers 30°C, for low temperature boilers 37°C and for other heaters 50°C return temperature (at heater inlet).					
(2) High temperature regime means 60°C return temperature at heater inlet and 80°C feed temperature at heater outlet.					

## 23.PRODUCT FICHE

BAXI LUNA DUO-TEC MP+		1.115	1.130	1.150
Space heating - Temperature application		Medium	Medium	Medium
Water heating - Declared load profile				
Seasonal space heating energy efficiency class				
Water heating energy efficiency class				
Rated heat output ( <i>Prated or Psup</i> )	kW	113	122	140
Space heating - Annual energy consumption	GJ			
Water heating - Annual energy consumption	kWh <sup>(1)</sup> GJ <sup>(2)</sup>			
Seasonal space heating energy efficiency	%			
Water heating energy efficiency	%			
Sound power level L <sub>WA</sub> indoors	dB	58	60	64
(1) Electricity (2) Fuel				

SECTION A

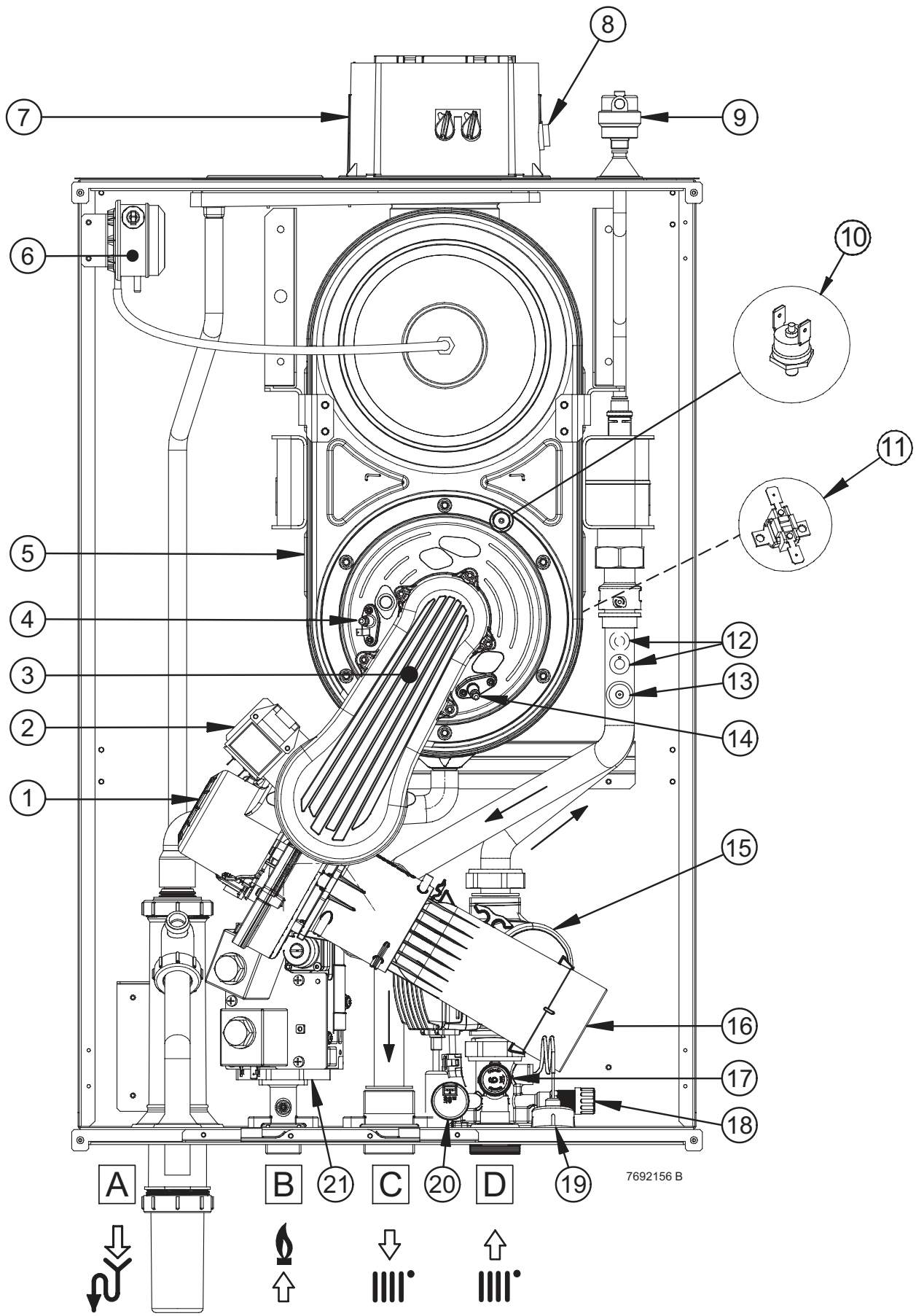

	<b>it</b>	<b>en</b>
<b>1</b>	Ventilatore	Fan
<b>2</b>	Accenditore	Spark generator
<b>3</b>	Collettore miscela aria-gas	Air/gas blend manifold
<b>4</b>	Elettrodo di accensione	Ignition electrode
<b>5</b>	Scambiatore primario	Primary exchanger
<b>6</b>	Pressostato fumi	Fumes pressure switch
<b>7</b>	Raccordo scarico fumi coassiale	Coaxial flue connector
<b>8</b>	Sonda fumi	Flue sensor
<b>9</b>	Valvola di sfogo aria automatica	Automatic air vent
<b>10</b>	Termostato flangia scambiatore	Exchanger flange thermostat
<b>11</b>	Termofusibile	Thermal fuse
<b>12</b>	Sonda NTC riscaldamento (mandata e ritorno)	NTC water heating sensor (flow and return)
<b>13</b>	Termostato di sicurezza (sovratemperature)	Safety overflow temperature thermostat
<b>14</b>	Elettrodo di rivelazione di fiamma	Flame detection electrode
<b>15</b>	Pompa	Pump
<b>16</b>	Venturi	Venturi
<b>17</b>	Valvola di sicurezza idraulica	Hydraulic Safety valve
<b>18</b>	Rubinetto di scarico caldaia	Boiler drain tap
<b>19</b>	Manometro	Pressure gauge
<b>20</b>	Sensore di pressione idraulico	Hydraulic Pressure Sensor
<b>21</b>	Valvola gas	Gas valve
<b>A</b>	Attacco sifone scarico condensa	Trap condensate drain
<b>B</b>	Attacco ingresso GAS	Gas inlet connection
<b>C</b>	Attacco mandata acqua riscaldamento	Heating flow connection
<b>D</b>	Attacco ritorno acqua riscaldamento	Heating return connection

	<b>de</b>	<b>es</b>
<b>1</b>	Ventilator	Ventilador
<b>2</b>	Zünder	Encendedor
<b>3</b>	Sammelrohr Luft-/Gasgemisch	Colector de mezcla aire-gas
<b>4</b>	Zündungselektrode	Electrodo de encendido
<b>5</b>	Primär-Tauscher	Intercambiador primario
<b>6</b>	Abgas-Druckmesser	Presóstato de humos
<b>7</b>	Koaxiale Abgasleitung	Racord conexión humos coaxial
<b>8</b>	Abgasfühler	Sonda de humos
<b>9</b>	Automatisches Entlüftungsventil	Válvula de purga aire automática
<b>10</b>	Thermostat des Wärmetauscherflansches	Termostato brida intercambiador
<b>11</b>	Thermosicherung	Fusible térmico
<b>12</b>	NTC-Fühler Heizung (Vor- und Rücklauf)	Sonda NTC calefacción (ida y retorno)
<b>13</b>	Sicherheitsthermostat (Übertemperatur)	Termostato de seguridad (sobretemperaturas)
<b>14</b>	Flammenüberwachungselektrode	Electrodo de detección de llama
<b>15</b>	Pumpe	Bomba
<b>16</b>	Venturi	Venturi
<b>17</b>	Hydraulisches Sicherheitsventil	Válvula de seguridad hidráulica
<b>18</b>	Entleerungshahn Heizkessel	Grifo de descarga caldera
<b>19</b>	Druckmesser	Manómetro
<b>20</b>	Hydraulikdruckfühler	Sensor de presión hidráulico
<b>21</b>	Gasventil	Válvula del gas
<b>A</b>	Anschluss Kondenswasser-Auslasssiphon	Conexión desagüe condensados
<b>B</b>	Eingangsanschluss GAS	Conexión entrada de gas
<b>C</b>	Anschluss Heizwasservorlauf	Conexión ida agua Calefacción
<b>D</b>	Anschluss Heizwasserrücklauf	Conexión retorno agua Calefacción



	it	en	de	es
1	Fusibili	Fuses	Schmelzsicherungen	Fusibles
2	Alimentazione elettrica 230 V	230 V Power Supply	Stromversorgung 230 V	Alimentación eléctrica 230 V
3	Termostato Ambiente (TA)	Room Thermostat (RT)	Raumthermostat (RT)	Termostato Ambiente (TA)
4	Sonda mandata riscaldamento	Heating flow sensor	Vorlauffühler Heizung	Sonda impulsión calefacción
5	Sonda ritorno riscaldamento	Heating return sensor	Rücklauffühler Heizung	Sonda retorno calefacción
6	Sensore di pressione	Water pressure sensor	Drucksensor	Sensor de presión
7	Sonda fumi	Fumes sensor	Abgasfühler	Sonda de humos
8	Sonda bollitore sanitario	DHW tank sensor	Fühler Warmwasserspeicher	Sonda calentador ACS
9	Sonda ausiliaria 1	Auxiliary Sensor 1	Hilfsfühler 1	Sonda auxiliar 1
10	Sonda ausiliaria 2	Auxiliary Sensor 2	Hilfsfühler 2	Sonda auxiliar 2
11	Sonda esterna	Outdoor sensor	Außentemperaturfühler	Sonda exterior
12	Controllo Remoto	Remote Control	Fernbedienung	Control Remoto
13	Pompa	Pump	Pumpe	Bomba
14	Elettrodo di rivelazione fiamma	Flame sensor electrode	Flammenüberwachungselektrode	Electrodo de detección de llama
15	Elettrodo di accensione	Ignition electrode	Zündungselektrode	Electrodo de encendido
16	Accenditore	Igniter	Zünder	Encendedor
17	Valvola gas	Gas valve	Gasventil	Válvula del gas
18	Termostato di sicurezza	Safety Thermostat	Sicherheitsthermostat	Termostato de seguridad
19	Ventilatore	Fan	Ventilator	Ventilador
20	Pompa circuito di riscaldamento	Heating circuit pump	Pumpe Heizkreislauf	Bomba circuito de calefacción
21	Pompa bollitore sanitario	DHW boiler tank pump	Pumpe Warmwasserspeicher	Bomba calentador ACS
22	Termofusibile	Thermal fuse	Thermosicherung	Fusible térmico
23	Termostato flangia scambiatore	Exchanger flange thermostat	Thermostat des Wärmetauscherflansches	Termostato brida intercambiador
24	Pressostato fumi	Fumes pressure switch	Abgas-Druckmesser	Presóstato de humos
<b>C</b>	Celeste	Blue	Hellblau	Celeste
<b>M</b>	Marrone	Brown	Braun	Marrón
<b>N</b>	Nero	Black	Schwarz	Negro
<b>R</b>	Rosso	Red	Rot	Rojo
<b>G/V</b>	Giallo/Verde	Yellow/Green	Grüngelb	Amarillo/Verde
<b>V</b>	Verde	Green	Grün	Verde
<b>B</b>	Bianco	White	Weiß	Blanco
<b>G</b>	Grigio	Grey	Grau	Gris
<b>Y</b>	Giallo	Yellow	Gelb	Amarillo
<b>P</b>	Viola	Violet	Violett	Violeta

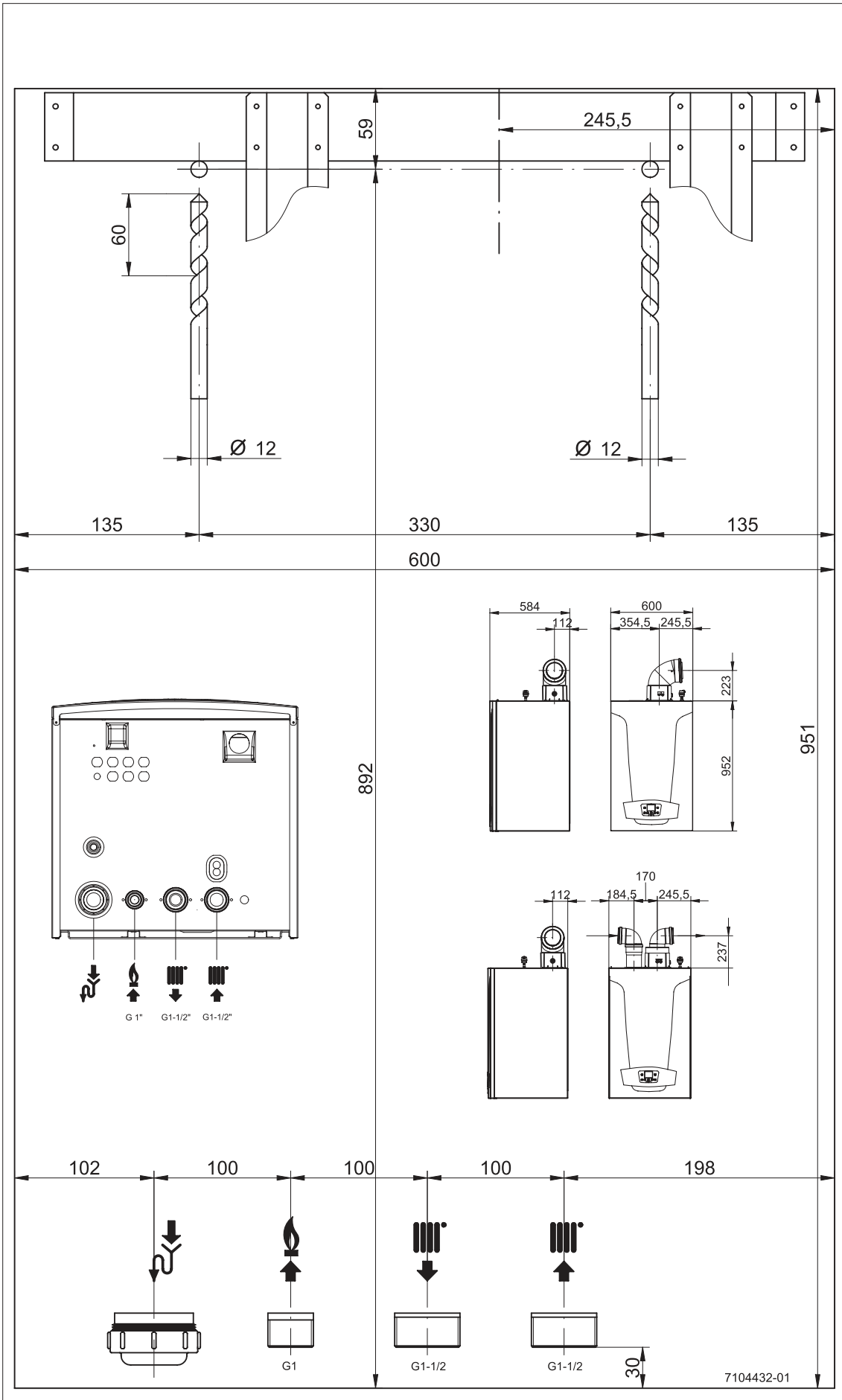



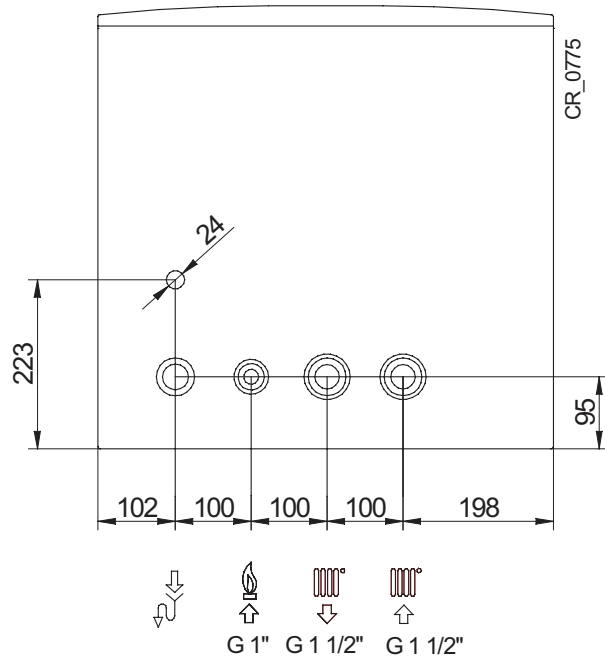
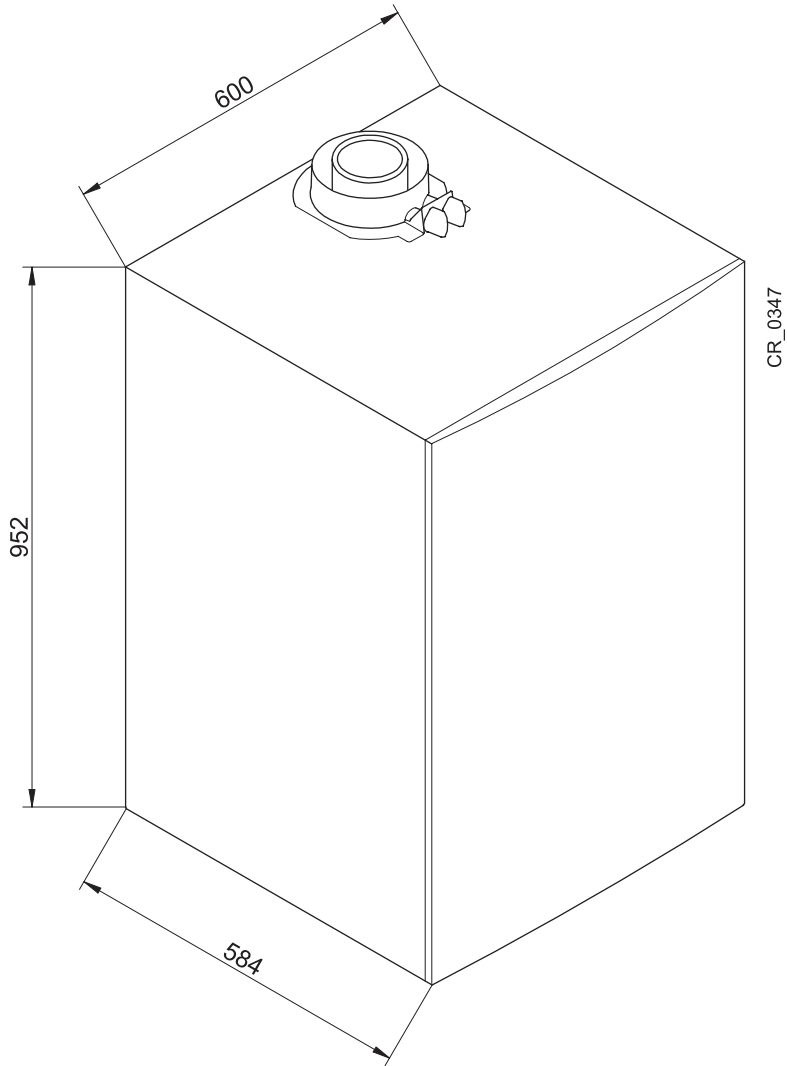

SECTION D

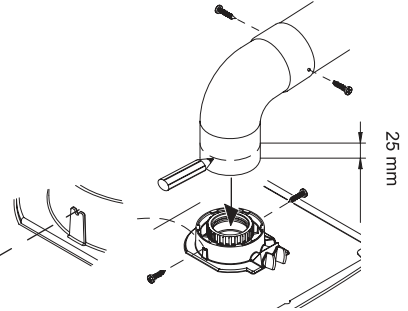
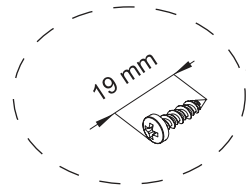
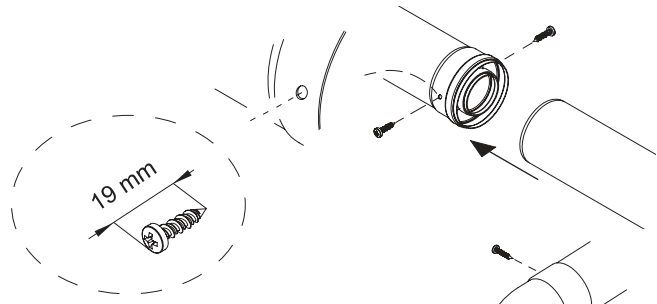
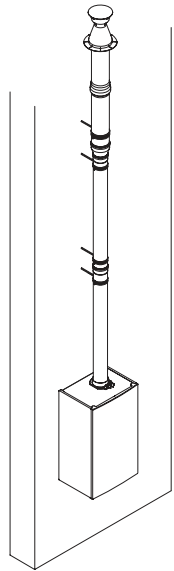
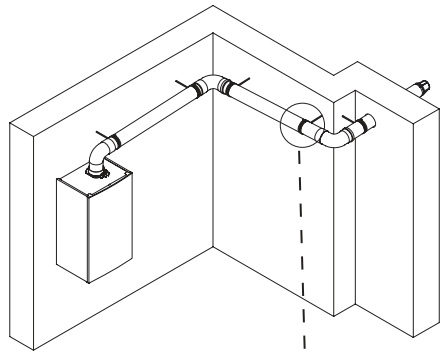

CG\_2274

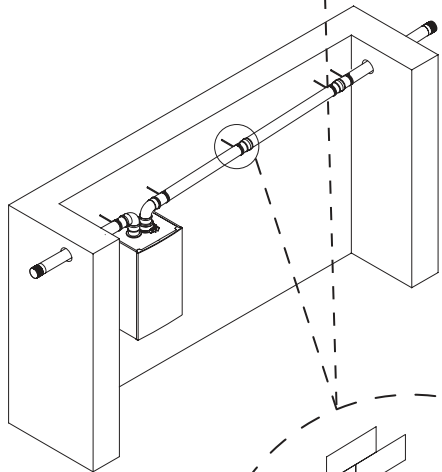
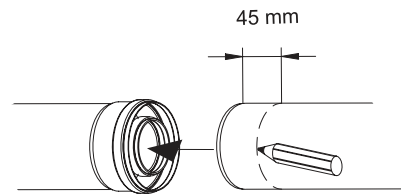

CG\_2275

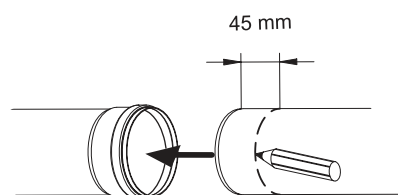
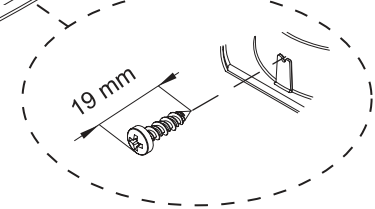
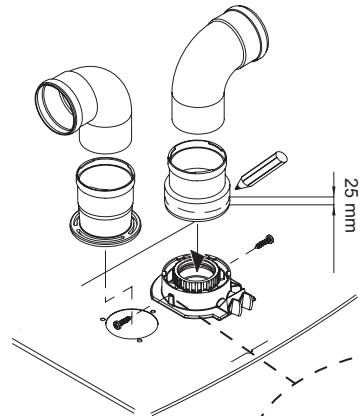
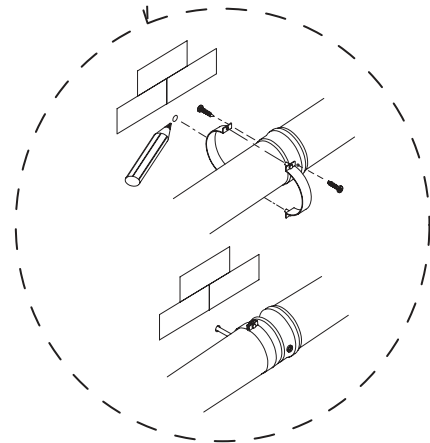

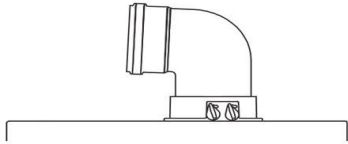

<b>A B</b>	Lmax = 8 m - Ø 110/160 mm
<b>C D</b>	Lmax = 7 m - Ø 110/160 mm
<b>E F</b>	Lmax = 8 m - Ø 110/160 mm
<b>G</b>	Lmax = 6 m - Ø 110/160 mm
<b>H</b>	Lmax = 7 m - Ø 110/160 mm

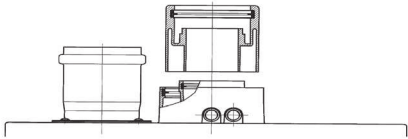

<b>I</b>	(L1+L2) max = 20 m - Ø 110 mm L1 max = 10 m
<b>L</b>	Lmax = 15 m - Ø 110 mm

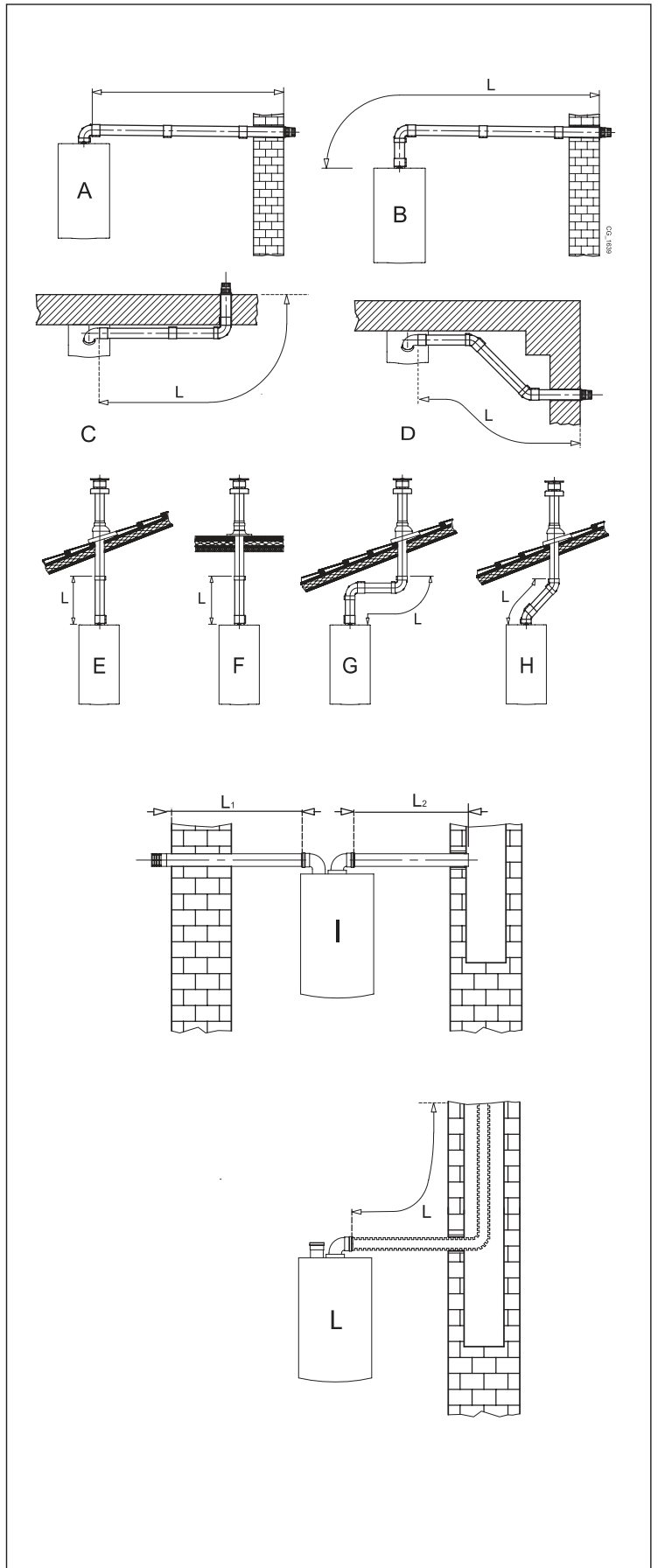

SECTION D

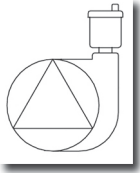

LUNA DUO-TEC MP+ 1.115 - 1.130

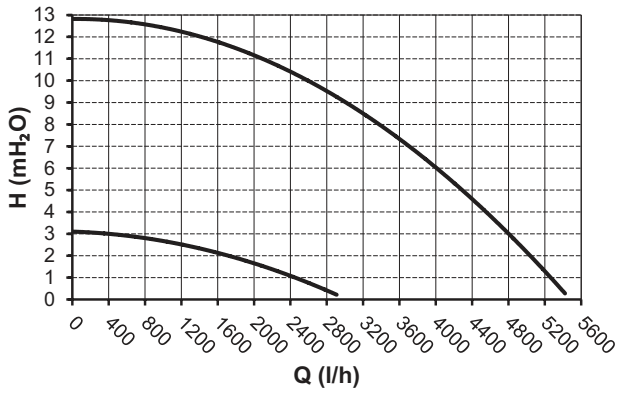

LUNA DUO-TEC MP+ 1.150

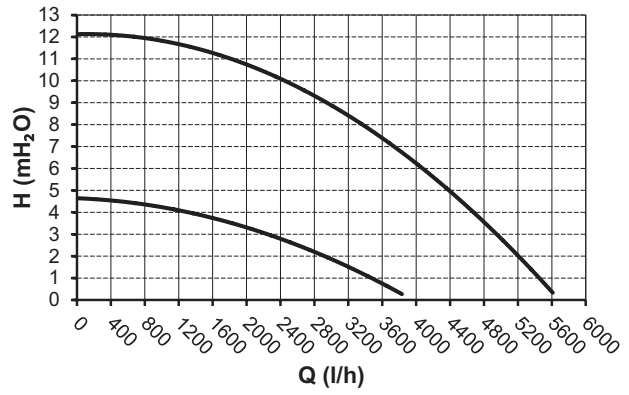

SIEMENS QAC34

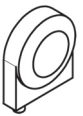

SECTION E

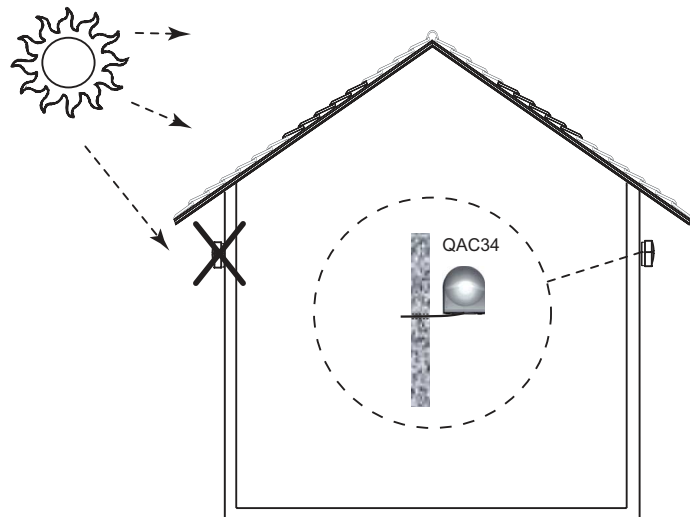
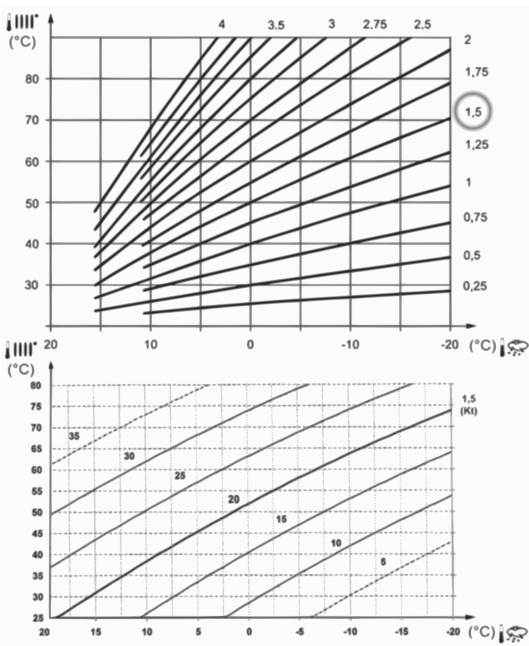

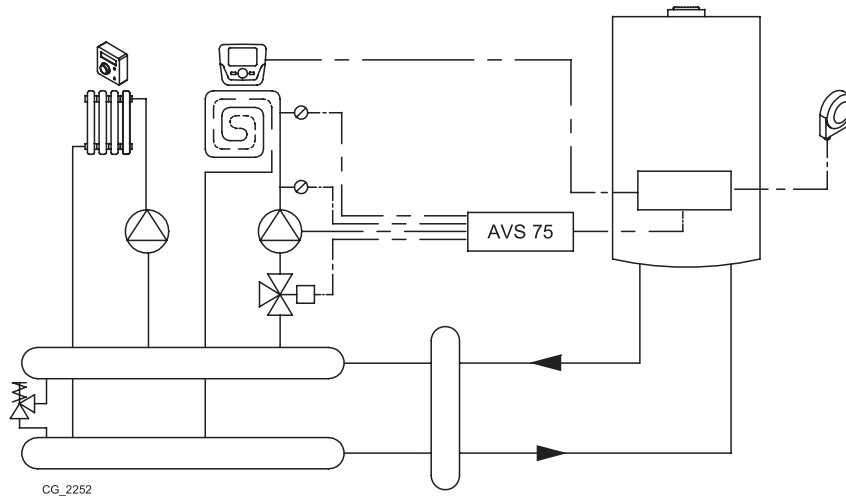
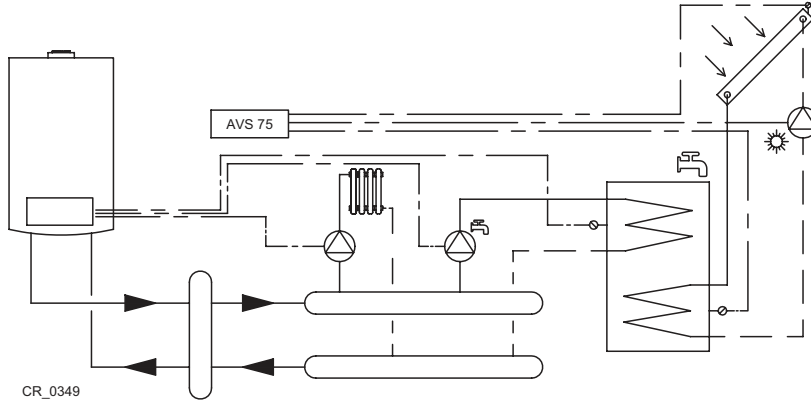
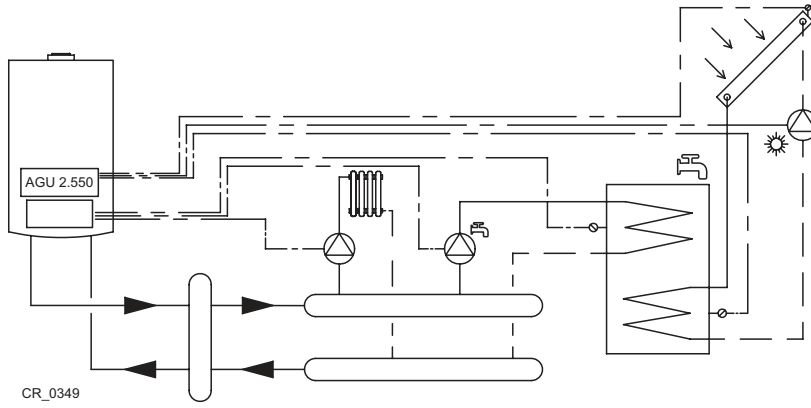
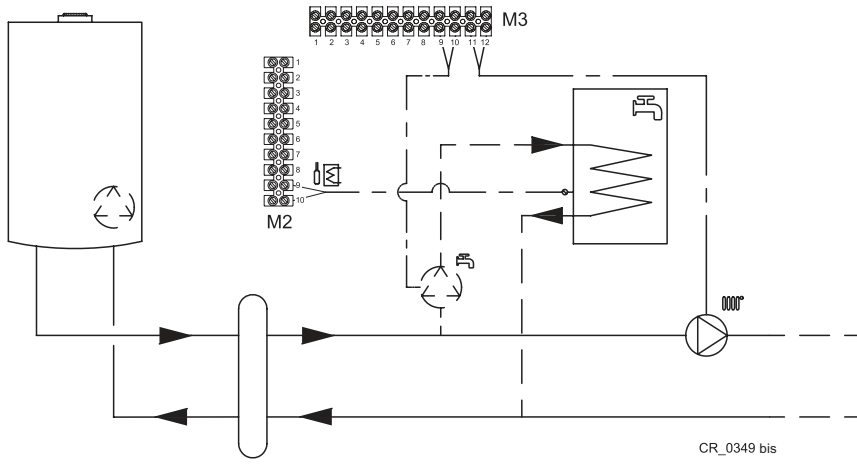

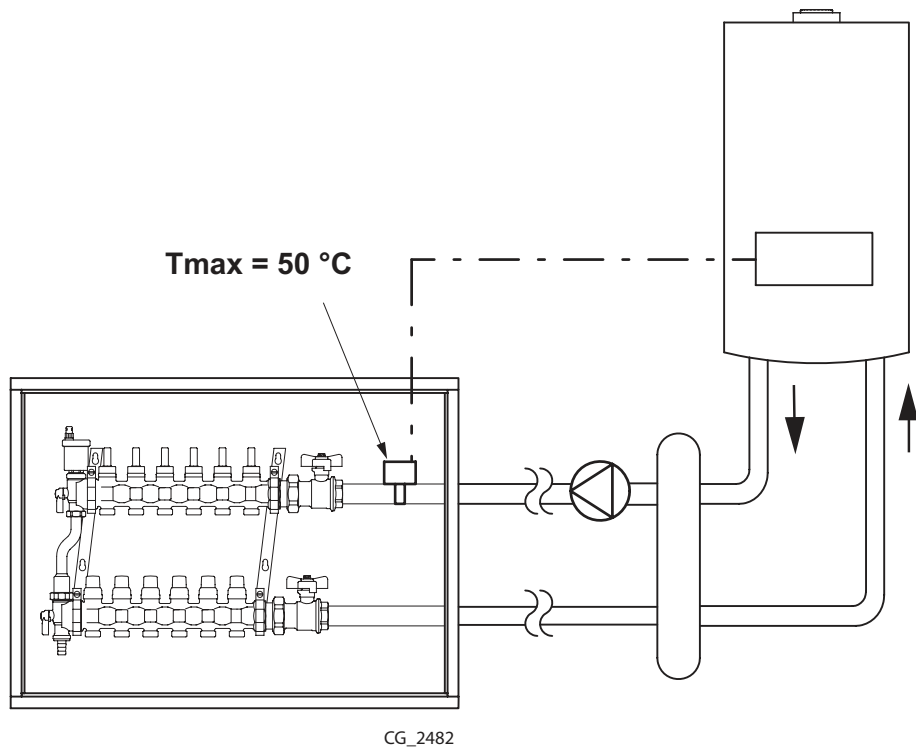
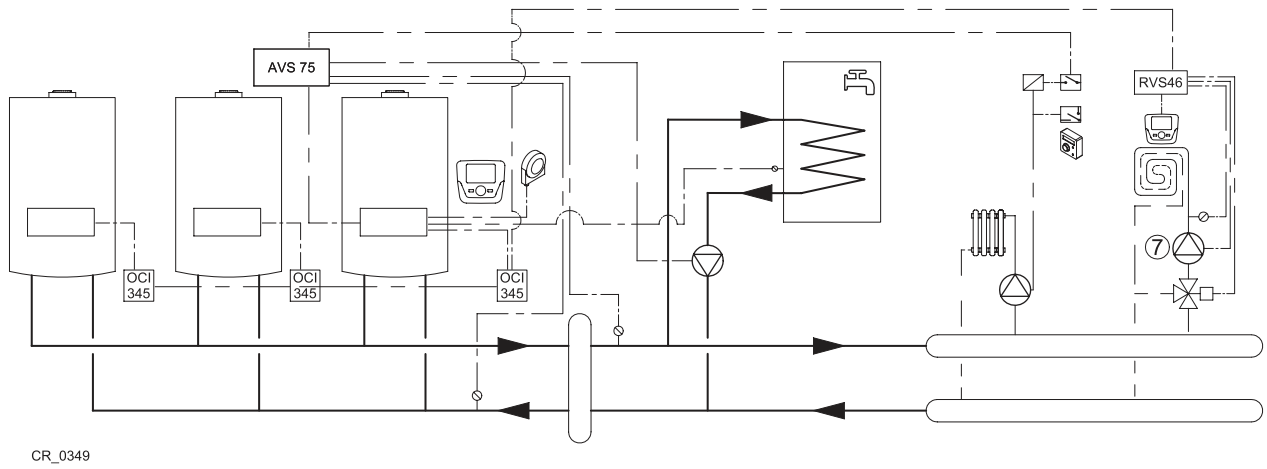
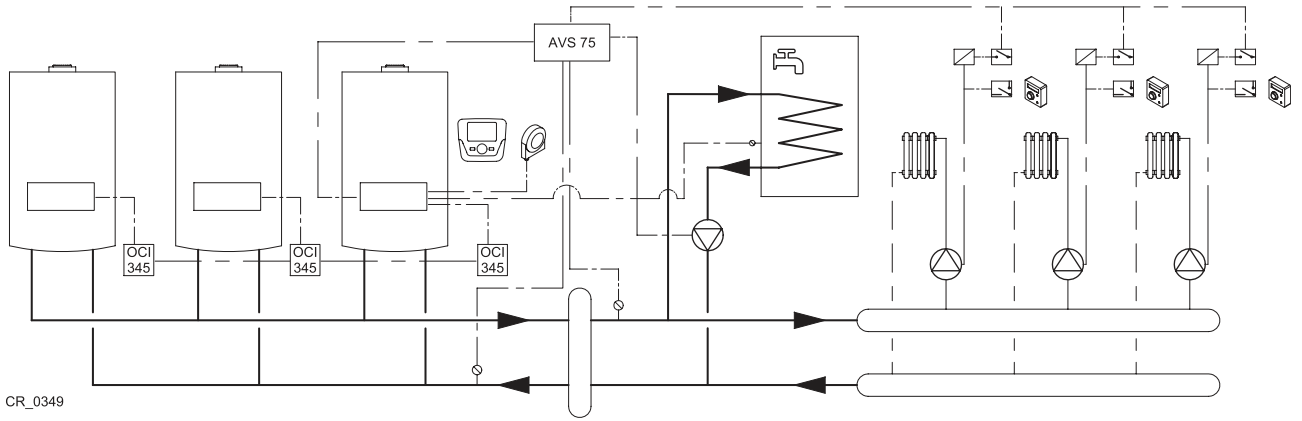









**BAXI**

*36061 Bassano del Grappa (VI) - ITALIA*

*Via Trozzetti, 20*

*Servizio clienti: tel. 0424-517800 – Telefax 0424-38089*

*[www.baxi.it](http://www.baxi.it)*