

Specification sheet

Project.:

Date: 29/10/2012

contact person:

Direct dialing:

Plate-Heat-Exchanger, bolted

Version: 4.05.4.0e [HVAC]

Pos.:	Unit: K042-19-1-N
--------------	--------------------------

Technical data	Hot side	Cold side
Fluid	Water	Water
Mass flow rate	[kg/s] 1.01	[kg/s] 0.26
Volume flow rate	[l/h] 3700.000	[m³/h] 0.926
Inlet temperature	[°C] 50.00	[°C] 28.00
Outlet temperature	[°C] 46.22	[°C] 43.00

Physical properties

Dynamic viscosity	[cP] 0.56714	[cP] 0.713625
Density	[kg/m³] 986.898	[kg/m³] 991.991
Specific heat capacity	[kJ/kgK] 4.17403	[kJ/kgK] 4.17929
Thermal conductivity	[W/mK] 0.63909	[W/mK] 0.632557

P.H.E characteristic values

Heat duty	[kW] 16.00	
Eff. heat transfer area	[m²] 0.70	
Log./Effective temperature difference	[K] 11.73/11.73	
Heat transfer coefficient reqd./act.	[W/m²K] 1944.32/3971.45	
Fouling factor	[m²K/W] 0.0002625	
Overdesign	[%] 104.26	
Pressure loss	[kPa] 20.283	[kPa] 1.457
No. of passes in series	1	1
No. of channels total		18
Mix of Channeltyp		9*HH

Construction

Weight Dry/Wet	[kg] approx. 33/35	
Volume	[dm³] 0.891	0.891
Design pressure gage	[bar] 16.0	
Max. working temperature	[°C] 110.00	
Material	Plates 1.4404 (0.50 mm)	
	Gaskets NBR	
	Frame C-Steel, DIN, max. no. of plates: 38	
	Painting RAL 5002, Standard	
Connection	Hot side F1 => F4 : Threaded pipe, male, DN 32, Stainless steel, G 1 1/4"	
	Cold side F3 => F2 : Threaded pipe, male, DN 32, Stainless steel, G 1 1/4"	

Remark

--

Construction sheet

Project.:

Date: 29/10/2012

contact person:
Direct dialing:

Plate-Heat-Exchanger, bolted

Version: 4.05.4.0e [HVAC]

Pos.:

Unit: K042-19-1-N

Dimensional sketch

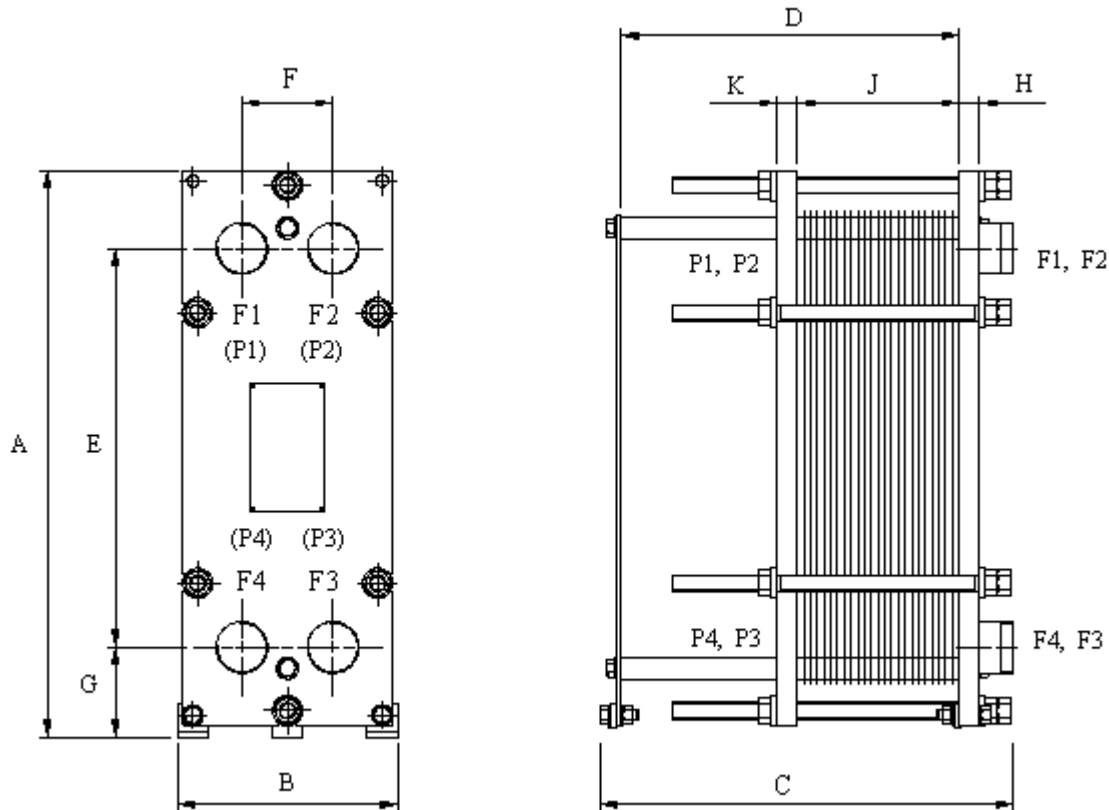

table of masses [appr. mm, inch], max. no. of plates 38

	:mm	:inch
A: Total height	:470	:18.5
B: Total width	:200	:7.9
C: Total length	:263.5	:10.4
D: Length of carrier bar	:180	:7.1
E: Distance between nozzles, vertical	:380	:15.0
F: Distance between nozzles, horizontal	:45	:1.8
G: midpoint of nozzle from the ground	:15	:0.6
H: Thickness of frame plate	:15	:0.6
K: Thickness of pressure plate	:0	:0.0
J: Length of the plate-package	:55.1	:2.2

Connections

Hot side: F1 => F4 :
Threaded pipe, male,
DN 32, Stainless steel, G 1 1/4"

Cold side: F3 => F2 :
Threaded pipe, male,
DN 32, Stainless steel, G 1 1/4"

Subject to change