

DEAERATOR



Art. 2250

Deaerator for heating systems

- Body made of CB753S brass
- Connection to pipelines: F-F
- 1/2" bottom plug
- Swiveling air vent valve
- Patent pending n° MI2011A002363

Available in the following sizes: 3/4" - 1" - 1"1/4 - 1"1/2 - 2"

1. DESCRIPTION

The FAR deaerator is used in heating and cooling systems to remove air bubbles from the circuit.

Air may be present in the circuit for several reasons:

- It may already be present during the filling phase and not properly discharged.
- It may be released from the water as the temperature increases.

- Air may be released with a decrease in pressure, such as might occur near pump aspirations or narrow sections of pipework. Air inside the system can cause corrosion in the interior of the pipe and damage to installed components (such as pumps) leading to malfunctions, loss of heat exchange efficiency and noise in the system.

2. TECHNICAL FEATURES

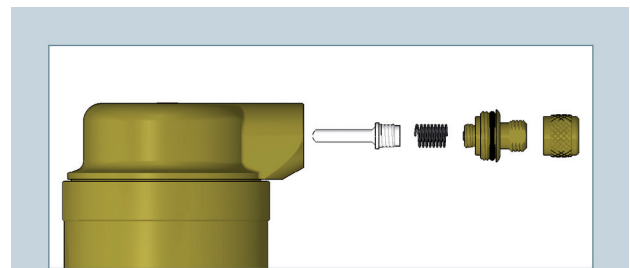
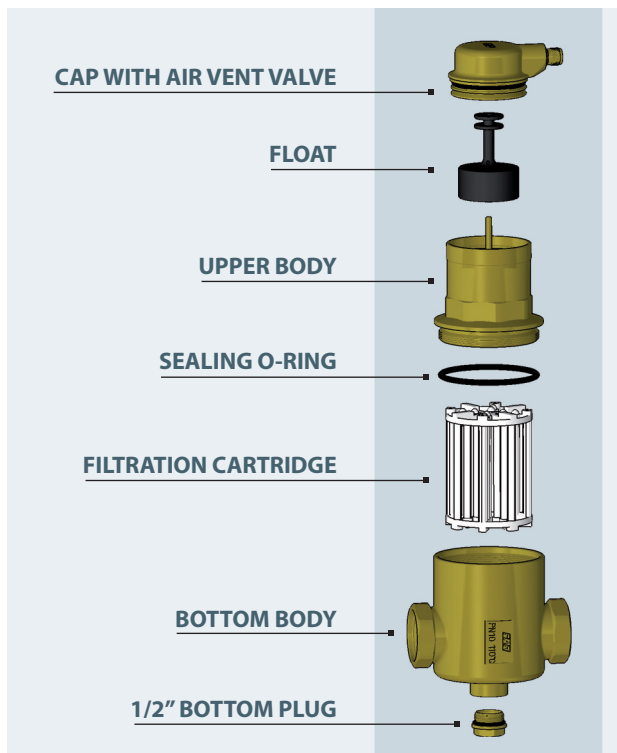

It is possible to rotate the air vent valve through 360° to position the drain appropriately, without needing to shut down the system.

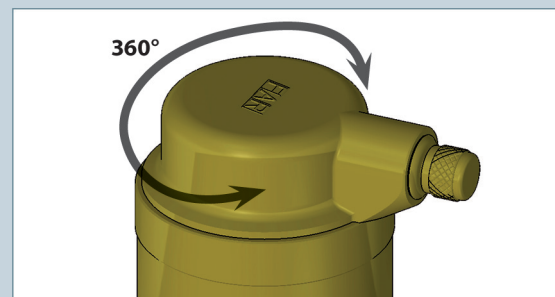

3. OPERATION

The deaerator is provided with an internal chamber which reduces flow rate and, decreases the drag force, facilitating separation of air. Inside this chamber a cartridge is placed transversally to the

direction of the flow, acting as a barrier to the air bubbles and reducing its kinetic energy. This effect is reinforced by the use of tongues on the vertical bars of the cartridge, which drives the air upwards.

PHASE OF OPERATION IN THE ABSENCE OF AIR BUBBLES

If there is no air in the circuit, the water inside the air vent valve keeps the float in a position that closes the shutter.

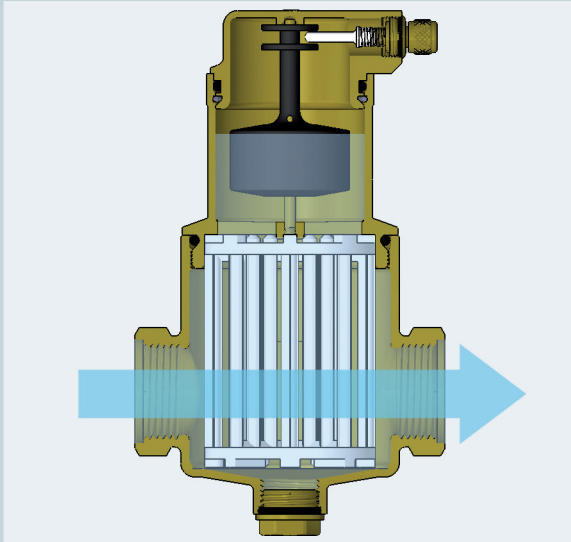

PHASE OF OPERATION IN THE PRESENCE OF AIR BUBBLES

The presence of air in the system reduces the level of water in the air vent valve thus lowering the float and opening the drain device.

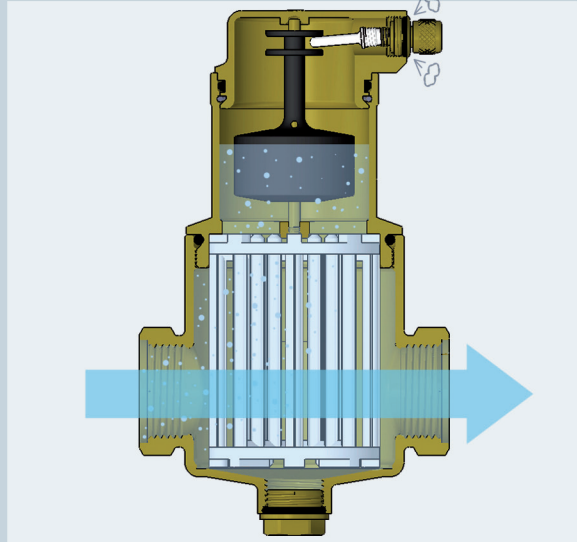

4. INSTALLATION

The ideal deaerator position in the heating system is on the supply pipe just after the boiler, where the flow temperature is high. This is because, as the water is heated in the boiler there is a possibility of bubbles being formed, causing damage to components or malfunctioning. It is recommended that the deaerator is installed between two shut-off valves to allow for maintenance.

CORRECT INSTALLATION IN GENERAL SYSTEMS

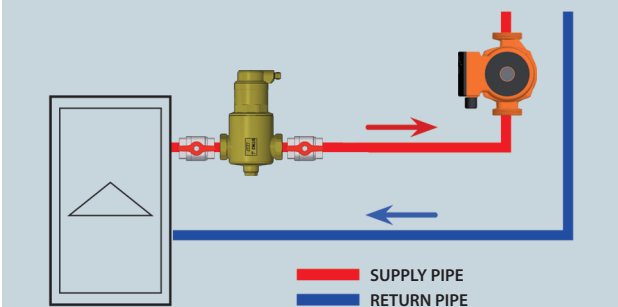

CORRECT INSTALLATION IN SYSTEM WITH MIXING VALVE

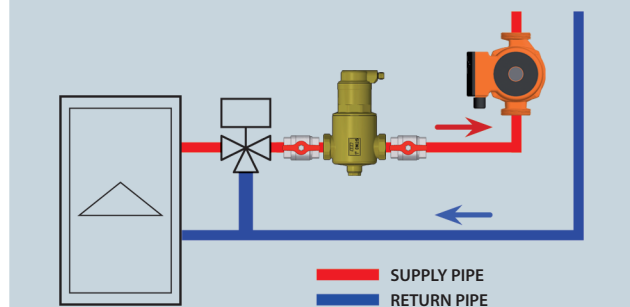

! In cooling systems the deaerator should be installed on the return pipe.

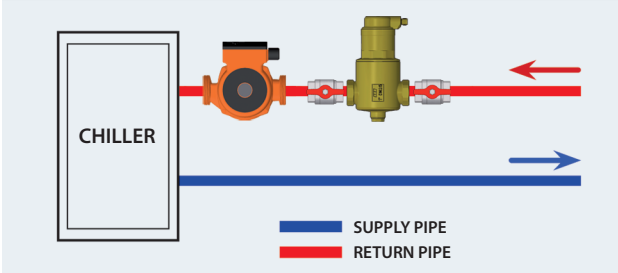

Bubbles mostly appear in the boiler on the surface separating flow and combustion chamber where there are high temperatures. As specified by Henry's Law, at certain values of pressure and temperature there is a certain concentration of gas dissolved in water. Any changes in temperature and pressure may cause the concentrations of dissolved gases to vary.

In particular, where there is an increase in temperature and a decrease in pressure, the gas tends to be liberated from the water.

With a decrease in temperature and an increase in pressure, the gas tends to remain in solution.

NOTE: For proper operation the deaerator should always be installed in a vertical position.

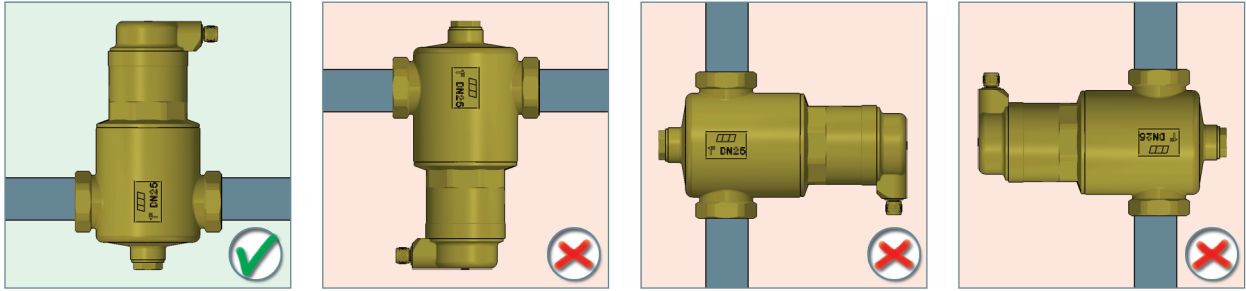

At the bottom of the deaerator there is a 1/2" threaded connection with a cap where a drain cock can be installed (art. 3447).

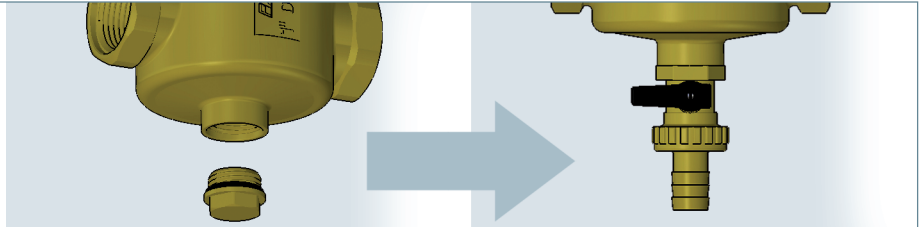

5. MAINTENANCE

In order to carry out maintenance, it is first necessary to close the shut-off valves located before and after the deaerator, and then unscrew the upper body using a plumbing wrench (picture 1). In the event of leakage from the air vent valve it is necessary to clean or replace it as follows. Remove the cap and use a 4 mm

Allen wrench to unscrew the air vent valve. Then proceed with cleaning or replacement (picture 2). For correct insertion of the stem on the float, turn upside down the cap and screw the air-vent valve (picture 3).

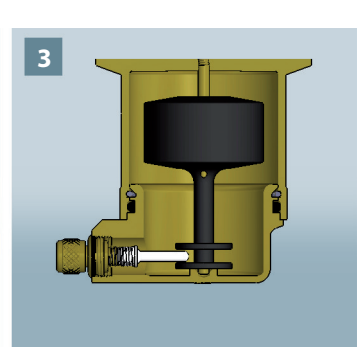
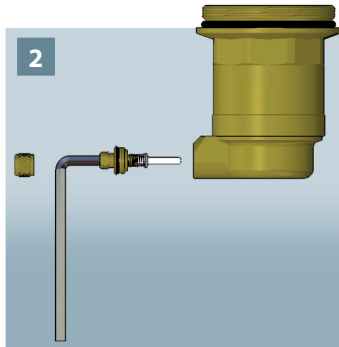
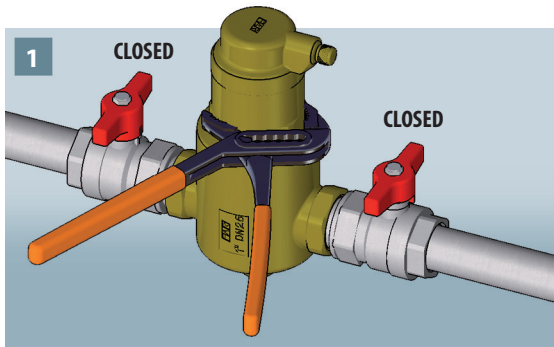

6. FLUID DYNAMIC AND DIMENSIONAL FEATURES

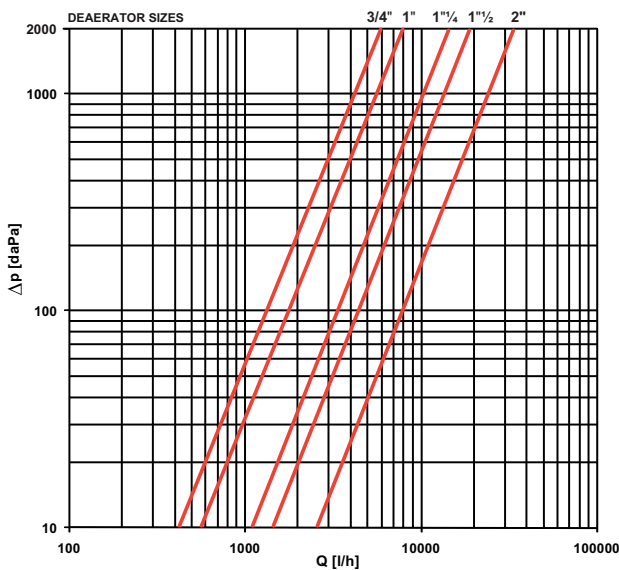

Sizes	3/4"	1"	1" 1/4	1" 1/2	2"
Kv [m³/h]	13,2	17,9	32,4	40,6	73,2

Dimensional features

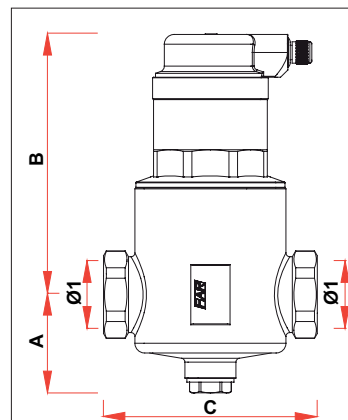

ARTICLE	Ø1	A	B	C
2250 34	G3/4	51	134	109
2250 1	G1	51	134	109
2250 114	G1 1/4	56	149	119
2250 112	G1 1/2	56	149	119
2250 2	G2	61	145	126