

# BAXI

## LUNA DUO-TEC E

<b>it</b>	<b>CALDAIA MURALE A GAS A CONDENSAZIONE</b> Manuale per l'uso destinato all'utente e all'installatore
<b>en</b>	<b>CONDENSING GAS WALL-HUNG BOILERS</b> Instructions manual for users and fitters
<b>de (AT)</b>	<b>KONDENSATIONS-WANDGASHEIZKESSEL</b> Gebrauchsanleitung für den Benutzer und Installateur
<b>cs</b>	<b>PLYNOVÉ ZÁVĚSNÉ KONDENZAČNÍ KOTLE</b> Návod na použití pro uživatele a instalatéry
<b>sk</b>	<b>PLYNOVÉ ZÁVESNÉ KONDENZAČNÉ KOTLE</b> Návod na použitie pre užívateľov a inštalatérov



Dear Customer,

Our company is confident our new product will meet all your requirements. Buying one of our products guarantees all your expectations: good performance combined with simple and rational use.

Please do not put this booklet away without reading it first: it contains useful information for the correct and efficient use of your product.

Our company declares that these products are marked **CE** in compliance with the essential requirements of the following Directives:

- Gas regulation (EU) **2016/426**
- Efficiency Directive **92/42/EEC**
- Electromagnetic Compatibility Directive **2014/30/EU**
- Low Voltage Directive **2014/35/EU**
- Ecodesign directive **2009/125/EC**
- Regulation (EU) No **2017/1369** (for boilers with Power<70kW)
- Ecodesign regulation (EU) No **813/2013**
- Energy labelling regulation (EU) No **811/2013** (for boilers with Power<70kW)



Our company, constantly striving to improve the products, reserves the right to modify the details given in this documentation at any time and without notice. These Instructions are only meant to provide consumers with use information and under no circumstance should they be construed as a contract with a third party.

**The appliance can be used by children aged 8 or over and by people with reduced physical, sensory or mental faculties, or who do not have the required experience or knowledge, provided they are supervised or have received instructions on using the appliance safely and understanding its intrinsic hazards. Children must not play with the appliance. The cleaning and maintenance operations reserved to the user must not be performed by unsupervised children.**

## CONTENT

DESCRIPTION OF SYMBOLS .....	25
SAFETY WARNINGS .....	25
GENERAL PRECAUTIONS .....	26
ENERGY-SAVING TIPS .....	26
1. COMMISSIONING THE BOILER .....	27
1.1 ADJUSTING THE CH AND DHW FLOW TEMPERATURE .....	27
1.2 OPERATING MODES .....	27
2. PROLONGED SHUTDOWN. ANTI-FREEZE PROTECTION .....	28
3. GAS CONVERSION .....	28
4. FAULTS .....	28
5. BOILER INFORMATION MENU .....	29
6. SWITCHING OFF THE BOILER .....	29
7. FILLING THE SYSTEM .....	29
8. ROUTINE MAINTENANCE INSTRUCTIONS .....	29
INSTRUCTIONS PRIOR TO INSTALLATION .....	30
9. INSTALLING THE BOILER .....	30
9.1 CONTENTS OF PACK .....	30
9.2 BOILER DIMENSIONS AND GAS WATER CONNECTIONS .....	30
10. INSTALLING THE DUCTS .....	31
10.1 CONCENTRIC DUCTS .....	31
10.2 SEPARATE DUCTS .....	31
11. ELECTRICAL CONNECTIONS .....	32
11.1 CONNECTING THE ROOM THERMOSTAT .....	33
11.2 ACCESSORIES NOT INCLUDED IN THE SUPPLY .....	33
12. SPECIAL FUNCTIONS .....	34
12.1 INITIAL IGNITION .....	34
12.2 SYSTEM GAS EXTRACTION FUNCTION .....	34
12.3 CHIMNEY SWEEPER .....	34
12.4 COMBUSTION TEST (CO <sub>2</sub> ) .....	35
COMBUSTION ADJUSTMENT FUNCTION (CO <sub>2</sub> %) .....	35
13. GAS VALVE .....	35
13.1 GAS CONVERSION METHODS .....	35
14. PARAMETERS SETTING .....	36
14.1 ADJUSTING MAXIMUM HEATING POWER .....	37
15. TROUBLESHOOTING SERVICE FAULTS .....	38
16. ADJUSTMENT AND SAFETY DEVICES .....	40
17. PUMP CAPACITY/ HEAD .....	40

18.	ANNUAL SERVICING .....	41
18.1	HYDRAULIC UNIT .....	41
18.1.1	CLEANING THE COLD WATER FILTER .....	41
18.2	POSITIONING THE ELECTRODES .....	41
18.3	REPLACEMENT OF PARTS .....	42
	AUTOMATIC CALIBRATION FUNCTION .....	42
19.	DISMANTLING, DISPOSAL AND RECYCLING .....	42
20.	TECHNICAL SPECIFICATIONS .....	43
21.	TECHNICAL PARAMETERS .....	44
22.	PRODUCT FICHE .....	45

## DESCRIPTION OF SYMBOLS



### WARNING

Risk of damage to or malfunction of the appliance. Pay special attention to the warnings concerning danger to people.



### DANGER OF BURNS

Wait for the appliance to cool down before working on the parts exposed to heat.



### DANGER - HIGH VOLTAGE

Live components - electrocution hazard.



### DANGER OF FREEZING

Possible formation of ice due to low temperatures.



### IMPORTANT INFORMATION

Information to read with particular care as it is useful for the correct operation of the boiler.



### GENERIC PROHIBITION

It is forbidden to do/use the things indicated alongside the symbol.

## SAFETY WARNINGS

### SMELL OF GAS

- Switch off the boiler.
- Do not activate any electrical device (such as switching on the light).
- Put out any naked flames and open the windows.
- Call an Authorised Service Centre.

### SMELL OF COMBUSTION FUMES

- Switch off the boiler.
- Open all the doors and windows to ventilate the room.
- Call an Authorised Service Centre.

### FLAMMABLE MATERIAL

Do not use and/or store highly flammable material (thinners, paper, etc.) near the boiler.

## SERVICING AND CLEANING THE BOILER

Switch off the boiler before working on it.



The appliance is not intended to be used by persons with reduced physical, sensory or mental capacities, or who lack experience or knowledge, unless, through the mediation of a person responsible for their safety, they have had the benefit of supervision or of instructions on the use of the appliance.

## GENERAL PRECAUTIONS

This boiler has been designed to heat water to a temperature lower than boiling point at atmospheric pressure. It must be connected to a central heating system and to a domestic hot water supply system according to its performance and power output. Before having the boiler installed by a qualified service engineer, make sure the following operations are performed:

- Make sure that the boiler is adjusted to use the type of gas delivered by the gas supply. To do this, check the markings on the packaging and the data label on the appliance.
- Make sure that the flue terminal draft is appropriate, that the terminal is not obstructed and that no exhaust gases from other appliances are expelled through the same flue duct, unless the latter has been specially designed to collect exhaust gas from more than one appliance, in compliance with current laws and regulations.
- Make sure that, if the boiler is connected to existing flue ducts, these have been thoroughly cleaned as residual products of combustion may detach from the walls during operation and obstruct the flow of fumes.
- To ensure correct operation and maintain the warranty, observe the following precautions:

### 1. DHW circuit

**1.1** If the water is harder than 20 °F (1 °F = 10 mg calcium carbonate per litre of water), install a polyphosphate dispenser or an equivalent treatment system, compliant with current regulations.

**1.2** Thoroughly flush the system after installation of the appliance and before use.

**1.3** The materials used for the DHW circuit comply with Directive 98/83/EC.

### 2. Heating circuit

**2.1 New system:** Before installing the boiler, the system must be cleaned and flushed to eliminate residual thread-cutting swarf, solder and any solvents, using suitable off-the-shelf non-acid and non-alkaline products that do not damage metal, plastic and rubber parts. To protect the system from scale, use inhibitors such as SENTINEL X100 and FERNOX protector for heating circuits. Use these products in strict compliance with the manufacturers' instructions.

**2.2 Existing system:** Before installing the boiler, drain the system and clean it to remove sludge and contaminants, using suitable proprietary products. Recommended cleaning products are: SENTINEL X300 or X400 and FERNOX regenerator for heating circuits. Use these products in strict compliance with the manufacturers' instructions. Remember that the presence of foreign bodies in the heating system can adversely affect boiler operation (e.g. overheating and excessive noise of the heat exchanger).

Initial lighting of the boiler must be carried out by an authorised Service Engineer who must first ensure that:

- The rated data correspond to the supply (electricity, water and gas) data.
- That the installation complies with current regulations.
- The appliance is correctly connected to the power supply and earthed.



**Failure to observe the above will render the warranty null and void. The names of the Authorised Service Centres are indicated in the attached sheet. Prior to commissioning, remove the protective plastic coating from the boiler. Do not use any tools or abrasive detergents to do this as you may damage the painted surfaces.**



**Do not leave any packaging (plastic bags, polystyrene, etc.) within the reach of children as they are a potential source of danger.**

## ENERGY-SAVING TIPS

### Adjustment in the heating mode

Adjust the boiler flow temperature depending on the kind of system. For systems with radiators, set a maximum heating water flow temperature of approximately 60°C and increase this value if the required room temperature is not reached. For systems with radiant floor panels, do not exceed the temperature indicated by the system designer. Use the External Sensor and/or Control Panel to automatically adjust the flow temperature to atmospheric conditions or the indoor temperature. This ensures that no more heat than that effectively necessary is produced. Adjust the room temperature without overheating the rooms. Every extra degree centigrade means consuming approximately 6% more. Also room ambient temperature depending on how the rooms are used. For example, the bedroom or the least used rooms can be heated to a lower temperature. Use the programmable timer and set the night-time room temperature at approximately 5°C lower than that during the day. There is no appreciable saving to be achieved by setting it any lower. Only in case of a prolonged absence, such as a holiday, should the temperature setpoint be lowered. Do not cover radiators as this prevents the air from circulating correctly. Do not leave the windows partially open to ventilate the rooms but open them completely for a short period.

### Domestic hot water

Setting the domestic hot water at the required temperature without mixing it with cold water saves a lot of money. Additional heating wastes energy and creates additional scale.



**BAXI** a leading European manufacturer of hi-tech boilers and heating systems, has developed CSQ-certified quality management (ISO 9001), environmental (ISO 14001) and health and safety (OHSAS 18001) systems. This means that BAXI S.p.A. includes among its objectives the safeguarding of the environment, the reliability and quality of its products, and the health and safety of its employees.

Through its organisation, the company is constantly committed to implementing and improving these aspects in favour of customer satisfaction.



# 1. COMMISSIONING THE BOILER

To light the boiler correctly, proceed as follows:

- Check that the system pressure is correct (section 6);
- Power the boiler;
- Open the gas tap (yellow, positioned under the boiler);
- Select the required heating mode (section 1.2).

## Key to BUTTONS

	DHW temperature adjustment (+ to increase the temperature and – to decrease it)
	Heating water temperature adjustment (+ to increase the temperature and – to decrease it)
	Boiler operating information
	Operating mode: DHW – DHW & Heating – Heating Only
	Off – Reset – Exit menu/functions

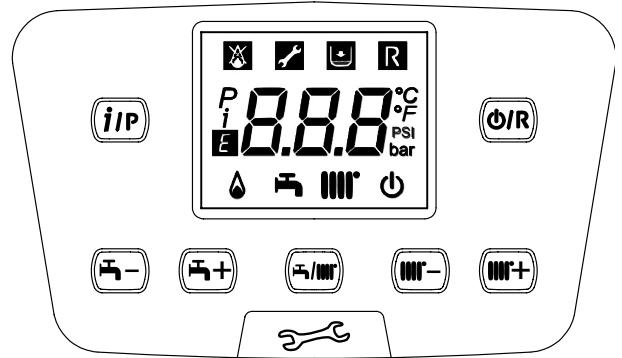

## Key to SYMBOLS

	Off: heating and DHW disabled (only boiler anti-freeze protection is active)		Burner lit
	Fault preventing the burner from lighting		DHW operating mode enabled
	Boiler/system water pressure low		Heating mode enabled
	Technical Service Centre call-in		Programming menu
	Manually resettable fault ()		Boiler information menu
	Fault in progress	°C, °F, bar, PSI	Set unit of measurement (SI/US)

## 1.1 ADJUSTING THE CH AND DHW FLOW TEMPERATURE

Press and respectively to adjust the CH and DHW flow temperature (if an external storage boiler is fitted). When the burner is lit, the display shows the symbol .

**HEATING:** while the boiler is operating in the heating mode, the display shows the flashing symbol and the heating delivery temperature (°C).

When connected to an External Sensor, indirectly adjust the room temperature (factory setting 20°C - see section 10.2.1).

**DHW:** While the boiler is operating in the DHW mode, the display shows the flashing symbol and the primary boiler circuit temperature (°C).

## 1.2 OPERATING MODES

SYMBOL DISPLAYED	OPERATING MODE
	DHW
	DHW & HEATING
	HEATING ONLY

To enable the appliance in **DHW - Heating** or **Heating only** press repeatedly and choose one of the three available modes.

To disable the boiler operating modes whilst keeping the anti-freeze function enabled, press for at least 3 seconds. Just the symbol appears on the display (the display backlighting flashes if the boiler is blocked).

## 2. PROLONGED SHUTDOWN. ANTI-FREEZE PROTECTION

Do not drain the whole system as filling up with water again could cause unnecessary and harmful scale to build up inside the boiler and the heating elements. If the boiler is not used during winter and is therefore exposed to the danger of frost, add some specific anti-freeze to the water in the system (e.g.: propylene glycol coupled with corrosion and scale inhibitors). The electronic boiler management system includes a "frost protection" function for the heating system which, when delivery temperature falls below 5°C, lights the burner until a delivery temperature of 30°C is reached.



*The function is operative if: the boiler is electrically powered, there is gas, system pressure is normal and the boiler is not blocked.*

## 3. GAS CONVERSION

The boilers can operate both on natural gas (G20) and LPG (G31). All gas conversions must be made by the AUTHORISED TECHNICAL SERVICE CENTRE.

## 4. FAULTS

The faults shown on the display are identified with the symbol **E** and a number (fault code). For a complete list of faults, see the following table.

If **R** appears on the display the fault must be RESET by the user. To RESET the boiler, press and hold down **ON** for 2 seconds. If faults are displayed frequently, call the Authorised Service Centre.

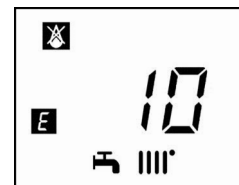

<b>E</b>	Description of fault	Action
10	External probe sensor faulty	Call the Authorised Service Centre.
12	Hydraulic differential pressure switch switching failure	Call the Authorised Service Centre.
13	Hydraulic differential pressure switch contacts stuck	Call the Authorised Service Centre.
15	Gas valve control error	Call the Authorised Service Centre.
18	Hydraulic circuit automatic filling in progress	Wait for the end of the filling cycle
19	Fault in system filling phase	Press and hold down <b>R</b> for at least 2 seconds.
20	NTC flow sensor faulty	Call the Authorised Service Centre.
28	NTC fumes sensor faulty	Call the Authorised Service Centre.
40	NTC return sensor faulty	Call the Authorised Service Centre.
50	NTC domestic hot water sensor faulty	Call the Authorised Service Centre.
53	Fumes outlet obstructed	Disconnect the boiler from the mains power supply for a few seconds. If the fault persists, call the authorised technical service centre
55	Electronic board not calibrated	Call the Authorised Service Centre.
83...87	Communication problem between boiler board and control unit. Probable short circuit on wiring.	Call the Authorised Service Centre.
92	Fumes fault during calibration (probable fumes recirculation)	Call the Authorised Service Centre.
109	Air in boiler circuit (temporary fault)	Call the Authorised Service Centre.
110	Safety thermostat tripped due to overtemperature (pump probably blocked or air in heating circuit).	Press and hold down <b>R</b> for at least 2 seconds.
117	Pressure in hydraulic circuit too high (> 2,7 bar)	Call the Authorised Service Centre.
118	Pressure in hydraulic circuit too low	Check that the pressure in the system is correct; See the FILLING THE SYSTEM section.
125	No circulation safety trip (control performed via a temperature sensor)	Press and hold down <b>R</b> for at least 2 seconds.
128	No flame	Press and hold down <b>R</b> for at least 2 seconds.
129	Loss of flame at ignition	Call the Authorised Service Centre.
130	Fumes NTC tripped due to overtemperature	Press and hold down <b>R</b> for at least 2 seconds.
133	Ignition failure (5 attempts)	Press and hold down <b>R</b> for at least 2 seconds.
134	Gas valve blocked	Press and hold down <b>R</b> for at least 2 seconds.
135	Internal board error	Call the Authorised Service Centre.
	Gas valve connection error	
154	Delivery/return probe control test	Call the Authorised Service Centre.

USER Section (en)

160	Fan fault	Call the Authorised Service Centre.
178	Intervention of safety thermostat for excess temperature in low temperature system	Call the Authorised Service Centre.
270	Overheating exchanger	Call the Authorised Service Centre.
317	162	Call the Authorised Service Centre.
384	164	Parasite flame (internal error)
385	165	Input voltage too low
431	Exchanger sensor faulty	Call the Authorised Service Centre.



*In the event of a fault, the display backlighting indicates the error code. 5 reset attempts can be performed after which the boiler shuts down. Wait 15 minutes before attempting to reset the boiler again.*

## 5. BOILER INFORMATION MENU

Press and hold down **(iP)** for at least 1 second, to display the information indicated in the table. Press **(O/R)** to exit.

<b>i</b>	DESCRIPTION	<b>i</b>	DESCRIPTION
00	Secondary fault internal code	06	Heating return temperature (°C)
01	Heating supply temperature (°C)	07	Flue sensor temperature (°C)
02	Outdoor temperature (°C)	08	Primary exchanger temperature (°C)
03	Indirect tank DHW temperature (boiler CH only)	09 - 13	Manufacturer information
04	Domestic hot water temperature (boiler with plate exchanger)	14	Identification Open Therm communication
05	Water pressure in heating system (bar)	15 - 18	Manufacturer information

## 6. SWITCHING OFF THE BOILER

To turn off the boiler, disconnect the electric power supply using the two-pole switch. In the "Off" operating mode **(O)** the boiler stays off but the electrical circuits remain powered and the anti-freeze function remains active.

## 7. FILLING THE SYSTEM

Regularly check that the pressure displayed on the pressure gauge "B" is 1 - 1.5 bar, with the boiler cold. If the pressure is too low, turn tap "A" to fill the boiler (figure to side).

A	Boiler/system filling tap
B	Pressure gauge



*Take special care when filling the heating system. In particular, open any thermostat valves in the system, ensure the water enters slowly in order to prevent the formation of air inside the primary circuit until operating pressure is reached. Lastly, vent any radiators in the system. BAXI declines all liability for damage deriving from the presence of air bubbles in the primary exchanger due to the incorrect or imprecise observance of the above.*



The boiler is fitted with a hydraulic pressure gauge which prevents the boiler from working if there is no water.



*If pressure drops occur frequently, have the boiler checked by the AUTHORISED TECHNICAL SERVICE CENTRE.*

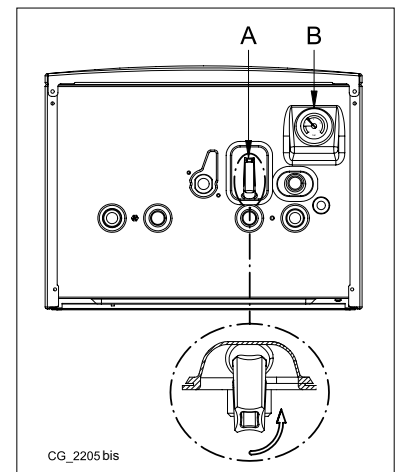

## 8. ROUTINE MAINTENANCE INSTRUCTIONS

To keep the boiler efficient and safe, have it checked by the Authorised Service Centre at the end of every operating period. Careful servicing ensures economical operation of the system.



## INSTRUCTIONS PRIOR TO INSTALLATION

The following notes and instructions are addressed to fitters to allow them to carry out trouble-free installation. Instructions for lighting and using the boiler are contained in the 'Instructions for Users' section. Installation, servicing and running of domestic gas-fired systems must be performed by qualified technicians, in compliance with current regulations.

Additionally, bear in mind the following:

- When installing the unit in environments with temperatures lower than 0°C, take the necessary precautions to avoid the formation of ice in the siphon and in the condensation drain.
- This boiler can be connected to any type of double- or single-pipe convector plate, radiator or thermoconvector. Design the system sections as usual, though, bearing in mind the available flow-head at the plate, as shown in section 16.
- Do not leave any packaging (plastic bags, polystyrene, etc.) within the reach of children as they are a potential source of danger.
- Initial lighting of the boiler must be carried out by an authorised Service Engineer, as indicated on the attached sheet.

Failure to observe the above will render the guarantee null and void.

### ADDITIONAL PUMP WARNING

If an additional pump is used on the heating system, position it on the boiler return circuit. This will allow the correct operation of the water pressure switch.

### SOLAR WARNING

If the instantaneous (mixed) boiler is connected to a system with solar panels, the maximum temperature of the domestic hot water entering the boiler must not exceed 60°C.



Do not leave any packaging (plastic bags, polystyrene, etc.) within the reach of children as they are a potential source of danger.

## 9. INSTALLING THE BOILER

The template outline is shown in annex "SECTION" C at the end of this manual.

After deciding the exact location of the boiler, fix the template to the wall. Connect the system to the gas and water inlets present on the lower bar of the template. Make sure the rear part of the boiler (back) is as parallel as possible to the wall (otherwise, shim the lower part). Fit two G3/4 taps (flow and return) on the central heating circuit; these taps make it possible to carry out important operations on the system without draining it completely. If you are either installing the boiler on an existing system or replacing one, as well as the above, fit a settling tank under the boiler on the system return line in order to collect any deposits and scale circulating in the system after flushing. After fixing the boiler to the template, connect the flue and air ducts, supplied as accessories, as described in the following sections. Connect the siphon to a drain trap, making sure the slope is continuous. Avoid horizontal stretches.



Do not lift the boiler exerting pressure on the plastic parts like the siphon and the flue turret.



Tighten the boiler water connections with care (maximum tightening torque 30 Nm).



Before starting up the boiler, fill the water siphon to prevent the fumes from diffusing in the room.

### 9.1 CONTENTS OF PACK

- Template (see figure in annex "SECTION" C at the end of this manual)
- Boiler support bar
- 8 mm expansion grips and pressure screws

ACCESSORIES supplied on request:

- heating flow/return taps and telescopic joint
- Gas tap (1) and Water inlet tap (2)

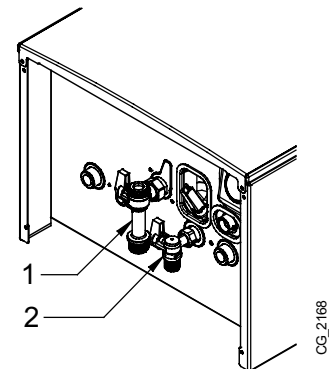

### 9.2 BOILER DIMENSIONS AND GAS WATER CONNECTIONS

The dimensions of the boiler and the relative installation positions of the water connections are shown in the annex "SECTION" C at the end of the manual.

<b>A</b>	Condensate drain point	<b>D</b>	GAS inlet
<b>B</b>	Heating flow	<b>E</b>	Cold domestic water inlet / System filling tap
<b>C</b>	D.H.W. outlet (G1/2") / Boiler heating flow (G3/4")	<b>F</b>	Heating return



## 10. INSTALLING THE DUCTS

The boiler is easy and flexible to install thanks to the extensive range of available accessories, as described below. The boiler has been designed for connection to a vertical or horizontal coaxial flue-air duct. The boiler can also be used with separate ducts using the accessory splitting kit.

See figure in annex "SECTION" C at the end of this manual.

### WARNINGS

**C13, C33** The terminals for separate flues must be fitted inside a 50 cm square. Detailed instructions are provided with the individual accessories.

**C53** Do not fit the flue and air duct terminals on opposite walls of the building.

**C63** The pressure drop of the ducts must not exceed **100 Pa**. The ducts must be certified for this specific use and for a temperature in excess of 100°C. The flue terminal must be certified to EN 1856-1.

**C43, C83** The flue terminal or flue duct must be suitable for the purpose.



**SOME DUCT INSTALLATION EXAMPLES ARE SHOWN AT THE END OF THIS MANUAL, SEE FIGURE IN ANNEX "SECTION" D.**



**For optimal installation, the accessories supplied by the manufacturer should be used.**



**To optimise operating safety, make sure the flue ducts are firmly fixed to the wall with suitable brackets. The brackets must be positioned over the joints at a distance of approximately 1 metre from one another.**

### 10.1 CONCENTRIC DUCTS

This type of duct is used to discharge exhaust fumes and draw combustion air both outside the building and if a LAS flue is fitted. The 90° coaxial bend allows the boiler to be connected to a flue-air duct in any direction as it can be rotated by 360°. It can also be used as a supplementary curve combined with a coaxial duct or a 45° curve.

If fumes are discharged outside the building, the flue-air duct must protrude at least 18 mm from the wall to allow an aluminium weathering surround to be fitted and sealed to avoid water infiltrations.

- A 90° bend reduces the total duct length by 1 metre.
- A 45° bend reduces the total duct length by 0.5 metres.
- The first 90° bend is not included when calculating the maximum available length.

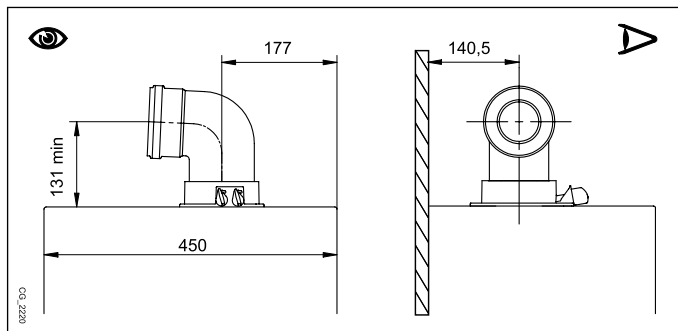

Secure the intake pipes with two galvanised screws with a diameter of 4.2 mm and a maximum length of 19 mm.



**Before securing the screws, make sure that at least 45 mm of the pipe is inserted into the gasket (see the figures in annex "SECTION" D at the end of this manual).**



**Make sure there is a minimum downward slope of 5 cm per metre of duct towards the boiler.**



**SOME OUTLET DUCT INSTALLATION EXAMPLES AND THEIR RELATIVE MAXIMUM LENGTHS ARE SHOWN IN ANNEX "SECTION" D AT THE END OF THIS MANUAL.**

### 10.2 SEPARATE DUCTS

This type of installation makes it possible to discharge exhaust fumes both outside the building and into single flue ducts. Comburent air can be drawn in at a different location from that of the flue terminal. The accessory splitting kit comprises a flue duct adaptor (80) (B) and an air duct adaptor (A). For the air duct adaptor, fit the screws and seals previously removed from the cap.

The 90° bend is used to connect the boiler to the inlet and outlet ducts, adapting them to various requirements. It can also be used as a supplementary curve combined with a duct or a 45° bend.

- A 90° bend reduces the total duct length by 0.5 metres.
- A 45° bend reduces the total duct length by 0.25 metres.
- The first 90° bend is not included when calculating the maximum available length.

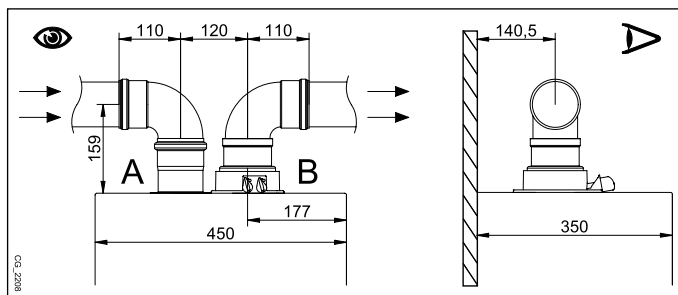

**Make sure there is a minimum downward slope of 5 cm per metre of duct towards the boiler.**

**SINGLE SPLITTING KIT (ALTERNATIVE ACCESSORY)**

For special installations of the fumes inlet/outlet ducts, the single splitting kit (C), supplied as an accessory, can be used. This accessory, in fact, can be used to move the inlet and outlet in any direction. This type of installation makes it possible to discharge exhaust fumes both outside the building and into single flue ducts. Comburent air can be drawn in at a different location from that of the flue terminal. The splitting kit is fixed to the boiler turret (100/60 mm) and allows the comburent air and outlet fumes to enter/leave the two separate ducts (80 mm). For further information, read the assembly instructions supplied with the accessory.

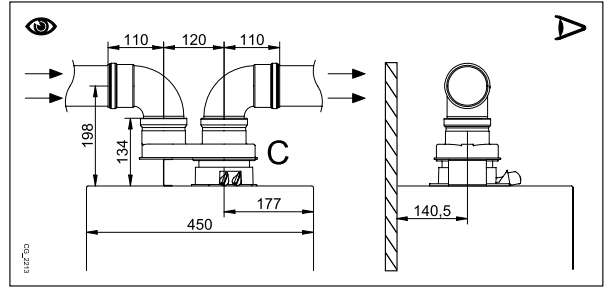

**SOME OUTLET DUCT INSTALLATION EXAMPLES AND THEIR RELATIVE MAXIMUM LENGTHS ARE SHOWN IN ANNEX "SECTION" D AT THE END OF THIS MANUAL.**

**11. ELECTRICAL CONNECTIONS**

This machine is only electrically safe if it is correctly connected to an efficient earth system in compliance with current safety regulations. Connect the boiler to a 230V single-phase earthed power supply using the supplied three-pin cable, observing correct Live-Neutral polarity.

**Use a double-pole switch with a contact separation of at least 3 mm.**

When replacing the power supply cable, fit a harmonised "HAR H05 VV-F" 3x0,75 mm<sup>2</sup> cable with a maximum diameter of 8 mm. To access the terminal block, remove the front boiler panel (fixed with two screws at the bottom), turn the control box downwards and access terminal blocks **M1**, **M2**, **M3**, used for the electrical connections, after removing the protective cover. The 3.15 A fast-blowing fuses are incorporated in the power supply terminal block (to check and/or replace the fuse, pull out the black fuse carrier).

SEE WIRING DIAGRAM IN ANNEX "SECTION" B AT THE END OF THIS MANUAL



**Make sure that the overall rated power input of the accessories connected to the appliance is less than 2A. If it is higher, install a relay between the accessories and the electronic board.**



**The connections in terminal blocks M1- M3 are high voltage (230 V). Before making connections, make sure the appliance is disconnected from the power supply. Respect the input polarity on terminal block M1: L (LINE) - N (NEUTRAL).**

**TERMINAL BLOCK M1**

(L) = Live (brown) - (N) = Neutral (light blue).

⊕ = Earth (yellow-green).

(1) (2) = contact for **Room Thermostat**.



**Put back the jumper on terminals 1-2 of boiler terminal block M1 if the room thermostat is not used or if the Remote Control, supplied as an accessory, is not installed.**

**TERMINAL BLOCK M2**

**Terminals 1 - 2:** connection to the Remote Control (low voltage) supplied as an accessory.

**Terminals 4 - 5 (common):** external Probe connection (supplied as an accessory)

**Terminals 3-6-7-8:** not used.

**Terminals 9-10:** storage boiler sensor connection.

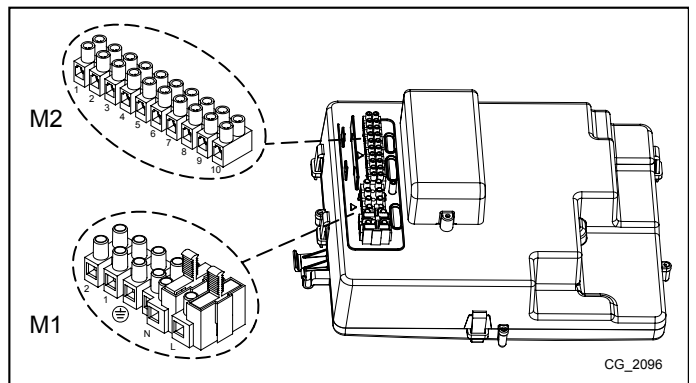

**If the appliance is connected to an underfloor system, install a limit thermostat to prevent the latter from overheating.**



**Use the relative cable grommets at the bottom of the boiler to thread the cables through to the terminal blocks.**

## 11.1 CONNECTING THE ROOM THERMOSTAT



The connections in terminal block M1 are high voltage (230 V). Before making connections, make sure the appliance is disconnected from the power supply. Respect polarity L (LIVE) - N (NEUTRAL).

To connect the Room Thermostat to the boiler, proceed as described below:

- switch off the boiler;
- access the terminal block **M1**;
- remove the jumper from the ends of contacts 1-2 and connect the wires of the Room Thermostat;
- switch on the boiler and make sure the Room Thermostat works correctly.

## 11.2 ACCESSORIES NOT INCLUDED IN THE SUPPLY

### 11.2.1 EXTERNAL SENSOR

To connect this accessory, see figure to side (terminals 4-5) and the instructions supplied with the sensor.

#### SETTING THE "Kt" CLIMATE CURVE

When the external sensor is connected to the boiler, the electronic board adjusts the flow temperature calculated according to the set **Kt** coefficient. Select the required curve by pressing as indicated in the chart in annex **SECTION E** for selecting the most appropriate one (00 to 90).

KEY TO CHART - "SECTION" E

	Flow temp		Outside temp
--	-----------	--	--------------

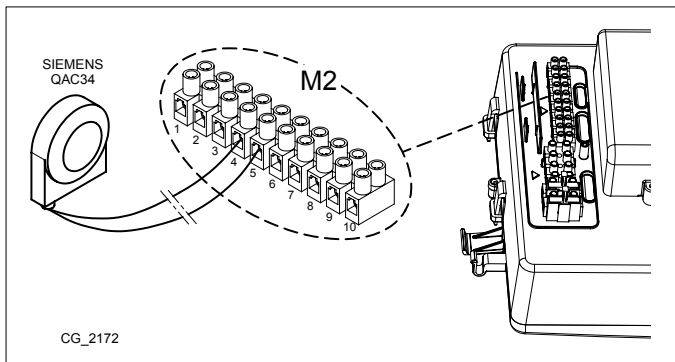

### 11.2.2 EXTERNAL STORAGE BOILER

The boiler can be electrically connected to an external storage boiler. A diagram of the hydraulic connection of the external storage boiler is shown in annex "**SECTION**" F. Connect the DHW priority sensor NTC to terminals 9-10 on terminal block **M2**. The sensitive element of the NTC sensor must be inserted in the special well located on the storage boiler. Make sure that the exchange capacity of the storage boiler coil is appropriate for the power of the boiler. Adjust DHW temperature (+35°C...+60°C) by pressing .

**IMPORTANT:** set parameter **P03 = 05** as described in section 14.

### 11.2.3 CONNECTING TO A ZONE SYSTEM

To use this function, install the programmable relay electronic board supplied as an accessory.

KEY TO ELECTRICAL CONNECTIONS (see diagram in annex "**SECTION**" G at the end of this manual).

<b>Z</b>	Zone (1..n)	<b>EV</b>	Zone electrovalve
<b>R</b>	Relay	<b>RT</b>	Room thermostat

The boiler can manage a zone heating system. The Room Unit (wall-mounted) can be used to control one zone while normal ambient thermostats can be used to control the other zones.

#### SYSTEM CONNECTIONS







- Connect the zone 1 valve/pump to terminals 1 - 3 of the relay board terminal block inside the boiler control box.
- Connect the Ambient Thermostat contact of the other zones to terminals 1-2 of terminal block M1 (CONNECTING THE AMBIENT THERMOSTAT section).









Check that parameter **P04=02**. Set parameter **P10** (SETTING PARAMETERS section).

## 12. SPECIAL FUNCTIONS

### 12.1 INITIAL IGNITION

When lighting the boiler for the first time perform the following procedure. After electrically powering the boiler the code "000" appears on the display. This means the appliance is ready for the "initial lighting" procedure.

- Press   together and hold down for 6 seconds. "On" appears on the display for 2 seconds followed by code "312" indicating that the "system venting" function is active. This function lasts 10 minutes.
- Afterwards, the boiler switches on, the display shows the code "000" alternating with the % of ignition power and the temperature value (°C). During this "gas recognition function" phase, that lasts approximately 7 minutes, the type of gas used is analysed. During this function, assure maximum heat exchange to the heating or DHW system (domestic hot water demand) in order to prevent the boiler from switching off due to overheating.
- If the boiler runs on natural gas, the display shows **NG** for approximately 10 seconds. The boiler is now ready for normal operation. If the display shows **LPG**, press  and  together and hold down for at least 4 seconds to exit without changing the factory setting.
- If the boiler runs on propane the display shows **LPG**. Press  for at least 6 seconds to confirm the gas effectively used. If the display shows **NG** and does not recognise the type of gas used, press  and  together and hold down for at least 4 seconds to exit the function and then change parameter **P02=01** as described in the "PARAMETER SETTINGS" section of the boiler instructions manual.

 *If the venting or gas recognition function is interrupted by a power blackout, start the function again when power is restored by pressing  and  together and holding them down for at least 6 seconds. If the display shows fault E118 (low pressure in hydraulic circuit) during the venting function, open the filling tap on the appliance and restore the correct pressure. If the gas recognition function is interrupted due to a fault (e.g.: E133 no gas) press  to reset and then press  and  (for at least 6 seconds) to restart the function again. If the gas recognition function is interrupted due to overheating, restart the function by pressing  and  and holding them down for at least 6 seconds.*

*The combustion of this appliance has been factory controlled, calibrated and set for operation with NATURAL GAS.*

*During the Gas Type Control Function, the combustion ratio will increase for a short period of time while the gas type is being established.*



During initial ignition, the burner may not ignite (causing the boiler to shut down) until any air in the gas pipes is vented. In this case, repeat the ignition procedure until gas reaches the burner. To reset boiler operation, press  for at least 2 seconds.



For the first few ignitions immediately after installation the system must implement a self-learning procedure to reach the correct ignition level.

### 12.2 SYSTEM GAS EXTRACTION FUNCTION





This function is used to facilitate the elimination of the air inside the heating circuit when the boiler is first installed or after maintenance when the water is drained from the primary circuit.

To enable the system gas extraction function press buttons   together for 6 seconds. When the function is active, **On** appears on the display for a few seconds, followed by programme row **312**.

The electronic board will activate a pump on/off cycle lasting 10 minutes. The function will automatically stop at the end of the cycle. To manually exit this function, press the above buttons together for 6 seconds once again.

### 12.3 CHIMNEY SWEEPER

This function enables the boiler to generate **maximum heating power**. After activation, the boiler power % can be adjusted from minimum to maximum in the DHW mode. The following procedure is used.

- Press buttons  and  together for at least 6 seconds. When the function is enabled, the displays shows "On" for a few seconds followed by programme row "303" alternated with the % of boiler power.
- Press   to gradually adjust power (sensitivity 1%).
- To exit press both buttons together for at least 6 seconds, as described in point one.



Press  to display the instantaneous flow temperature for 15 seconds.

## 12.4 COMBUSTION TEST (CO<sub>2</sub>)

For correct boiler operation, the content of (CO<sub>2</sub>- O<sub>2</sub>) in the combustion fumes must observe the tolerances indicated in the following table. If the value of (CO<sub>2</sub>- O<sub>2</sub>) is different, check the electrodes and their relative distances. If necessary, replace the electrodes and position them correctly. If the problem persists, use the following function.

		G20		G31			
		1.12 - 1.24 - 1.28 24 - 28 - 33 - 40		1.12		1.24 - 1.28 - 24 28 - 33 - 40	
		CO <sub>2</sub> %	O <sub>2</sub> %	CO <sub>2</sub> %	O <sub>2</sub> %	CO <sub>2</sub> %	O <sub>2</sub> %
Maximum power	Nominal value	8.7	5.4	10.5	5.2	10.0	6.0
	Permitted value	8.2 – 9.3	6.3 – 4.3	10.0 – 11.0	6.0 – 4.5	9.5 – 10.5	6.8 – 5.2
Ignition power	Nominal value	8.7	5.4	10.8	4.8	10.8	4.8
	Permitted value	8.2 – 9.3	6.3 – 4.3	10.3 – 11.3	5.5 – 4.1	10.3 – 11.3	5.5 – 4.1
Minimum power	Nominal value	8.8	5.2	10.0	6.0	10.0	6.0
	Permitted value	8.2 – 9.3	6.3 – 4.3	9.5 – 10.5	6.8 – 5.2	9.5 – 10.5	6.8 – 5.2



The CO<sub>2</sub>/O<sub>2</sub> values are with the cover closed.



The combustions analisys shall be done using an analyzer regularly calibrated.



During normal operation the boiler performs combustion control cycles. In this phase, CO values higher than 1000 ppm can occur for brief periods of time.

## COMBUSTION ADJUSTMENT FUNCTION (CO<sub>2</sub>%)

This function sets out to partially adjust the value of CO<sub>2</sub>%. The following procedure is used.

- Press buttons and together for at least 6 seconds. When the function is enabled, the displays shows "On" for a few seconds followed by programme row "304" alternated with the % of boiler power.
- After the burner is lit, the boiler reverts to maximum DHW power (100). When the display shows "100" it is possible to partially adjust the value of CO<sub>2</sub> %;
- press . The display shows "00" alternating with the function number "304" (Δ flashes);
- press to raise or lower the amount of CO<sub>2</sub> (from -5 to +5).
- press to save the new value and view the power value "100" on the display again (the boiler continues operating at maximum DHW power).

This procedure can also be used to adjust the quantity of CO<sub>2</sub> to the **ignition power** and to the **minimum power** by pressing after point 5 of the procedure described above.

- After saving the new value (point 5 of the procedure), press to take the boiler to its **ignition power**. Wait for the value of CO<sub>2</sub> to stabilise and then adjust as described in point 4 of the procedure (the power value is a number <> 100 and <> 0) then save (point 5).
- press again to take the boiler to **minimum power**. Wait for the value of CO<sub>2</sub> to stabilise and then adjust as described in point 4 of the procedure (power value = 00);
- to exit the function, press the buttons for at least 6 seconds as described in point 1.

## 13. GAS VALVE

This appliance does not require any mechanical adjustment on the valve. The system ensures electronic auto-adaptation.

### Gas valve key

Pi
Gas supply inlet pressure tap

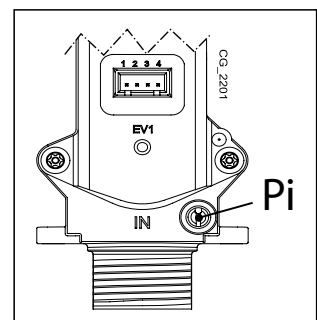

## 13.1 GAS CONVERSION METHODS

Only an Authorised Technical Assistance Service can convert boiler operation from **NATURAL GAS** to **LPG** or vice-versa. To perform calibration, set parameter **P02** as described in the PARAMETER SETTINGS section. Lastly, check the combustion parameters as described in the SPECIAL FUNCTIONS - CHECKING COMBUSTION PARAMETERS section.



When the gas change is completed the boiler data plate must be amended to indicate the new gas data.

# 14.PARAMETERS SETTING

To programme the parameters of the boiler electronic board, proceed as follows:

- Press and together and hold them down for 6 seconds until programme row "P01" appears on the display alternated with the set value;
- Press to scroll the list of parameters;
- Press the value of the selected begins flashing, press to change the value;
- Press to confirm the value or press to exit without saving.



Further information concerning the parameters listed in the following table are supplied together with the required accessories.



If the appliance is connected to an underfloor system, set the parameter P16=01.

	DESCRIPTION OF PARAMETERS	FACTORY SETTINGS						
		1.12	1.24	1.28	24	28	33	40
P01	Manufacturer information	01						
P02	Gas used 00 = METHANE - 01 = LPG	00						
P03	Hydraulic system 00 = instantaneous appliance 05 = appliance with external storage boiler 08 = heating only appliance	08	08	08	00	00	00	00
P04	Programmable relay 1 settings (See SERVICE instructions) 00 = no associated function 01 = relay contact closed with Room Thermostat demand (230V) 02 = relay contact closed with Remote Control demand (low voltage) 03 = system fill contact 04 = boiler faulty signal contact 05 = fan contact (kitchen fan) 06-07 = not used 08 = timed contact for enabling external DHW pump 09 = timed contact for enabling external DHW circulation pump via DHW programming from remote control 10 = relay contact closed with DWH demand active 11 - 12 - 13 = not used	02						
P05	Programmable relay 2 settings (See SERVICE instructions) Same configurations as relay 1 - P04	04						
P06	External probe input configuration (See SERVICE Instructions)	00						
P07..P09	Manufacturer information	--						
P10	Heating setpoint setting OT / RT (Remote Control - Open Therm / Room Thermostat 230V~)  00=the temperature request is the Remote Control setpoint 01=the temperature Request is the highest setpoint between Remote Control and PCB 02=the temperature request is the Remote Control setpoint. The Room Thermostat enable the gas boiler operates 03= the calculated setpoint depends on the origin of the request (PCB or Remote Control): a)PCB (Ambient Thermostat): the setpoint is set by pressing the +/- buttons on the boiler control panel, after having first disconnected the Remote Control from the boiler. b)Remote Control: the setpoint is set by modifying the "ULT" parameter (see Room Unit accessory manual, chapter "INSTALLER FUNCTIONS") c)Simultaneous request PCB - Remote Control the higher setpoint of the two requests is satisfied.	00						
P11..P12	Manufacturer information	--						
P13	Max. heating output (0-100%)	100	100	100	80	86	80	77
P14	Max DHW output (0-100%)	100						
P15	Min. heating output (0-100%)	00						
P16	Maximum CH setpoint (°C) 00 = 85°C - 01 = 45°C	00						
P17	Pump overrun time in heating mode (01-240 minutes)	03						

INSTALLER Section (en)

<b>P18</b>	Delay prior to new ignition in CH mode <b>(00-10 minutes) - 00=10 seconds</b>	03
<b>P19</b>	Manufacturer information	07
<b>P20</b>	Pump overrun time in DHW mode <b>(seconds)</b>	30
<b>P21</b>	Anti-legionellosis function (°C) <b>00...54 = Disabled - 55...67 = Enabled</b> (set the desired temperature value)	00
<b>P22</b>	Manufacturer information	00
<b>P23</b>	Maximum DHW setpoint temperature (ACS)	60
<b>P24</b>	Manufacturer information	35
<b>P25</b>	No water safety device	00
<b>P26..P31</b>	Manufacturer information	--
<b>P32..P41</b>	Diagnostics (See SERVICE Instructions)	--
<b>P67</b>	Open Therm (OT) settings (See SERVICE Instructions) <b>00 = Plug &amp; Play</b>	00

## 14.1 ADJUSTING MAXIMUM HEATING POWER

The maximum heating power of the boiler can be reduced to suit the requirements of the heating system it serves. A table showing parameter **P13** values according to the desired maximum power model is shown below for each single boiler. To access and edit parameter **P13** values, proceed as described in the PARAMETER SETTINGS section.

### Boiler model - PARAMETER P13 (%) / Heating output (kW)

<b>kW</b>	<b>1.12</b>	<b>1.24</b>	<b>1.28</b>	<b>24</b>	<b>28</b>	<b>33</b>	<b>40</b>
<b>2</b>	<b>0</b>						
<b>3</b>	10						
<b>3,5</b>	15	<b>0</b>		<b>0</b>			
<b>4</b>	20	2	<b>0</b>	2	<b>0</b>		
<b>5</b>	30	7	4	7	4	<b>0</b>	
<b>6</b>	40	12	8	12	8	4	<b>0</b>
<b>7</b>	50	17	13	17	13	7	3
<b>8</b>	60	22	17	22	17	11	6
<b>9</b>	70	27	21	27	21	14	9
<b>10</b>	80	32	25	32	25	18	11
<b>12</b>	<b>100</b>	41	33	41	33	25	17
<b>14</b>		51	42	51	42	32	23
<b>16</b>		61	50	61	50	39	29
<b>18</b>		71	58	71	58	46	34
<b>20</b>		80	67	<b>80</b>	67	54	40
<b>22</b>		90	75		75	61	46
<b>24</b>		<b>100</b>	83		<b>86</b>	68	51
<b>26</b>			92			75	57
<b>28</b>			<b>100</b>			<b>80</b>	63
<b>30</b>							69
<b>32</b>							74
<b>33</b>							<b>77</b>



## 15. TROUBLESHOOTING SERVICE FAULTS

The faults shown on the display are identified with the symbol **E** and a number (fault code). For a complete list of faults, see the following table.

If **R** appears on the display the fault must be RESET by the user.

To RESET the boiler, press and hold down **(ON)** for 2 seconds. If faults are displayed frequently, call the Authorised Service Centre.

<b>E</b>	Description of fault	Service action
10	External probe sensor faulty	Check the sensor (*).
12	Hydraulic differential pressure switch switching failure	Check correct operation of the pressure switch and the wiring.
13	Hydraulic differential pressure switch contacts stuck	See the actions indicated in E12
15	Gas valve control error	Check the connections between the gas valve and the electronic board. If necessary, replace the electronic board.
18	Hydraulic circuit automatic filling in progress	Wait for the end of the filling cycle.
19	Fault in system filling phase	Check the filling tap.
20	NTC flow sensor faulty	Check the sensor (**). Check the continuity of the probe wiring. Make sure the wiring has not shorted.
28	NTC fumes sensor faulty	Check the fumes NTC probe (***). Check the continuity of the probe wiring. Make sure the wiring has not shorted.
40	NTC return sensor faulty	See the actions indicated in E20
50	NTC domestic hot water sensor faulty	See the actions indicated in E20
53	Fumes outlet obstructed	Check that the drainage pipe is free from obstructions. Switch off the electric power supply to the boiler for a few seconds.
55	Electronic board not calibrated	Activate the automatic calibration function described in the spare parts instructions sheet.
83...87	Communication problem between boiler board and control unit. Probable short circuit on wiring.	Check the wiring between the Ambient Unit and the electronic board or RF link.
92	Fumes fault during calibration (probable fumes recirculation)	Check for any recirculation of fumes. Activate the automatic calibration function described in the paragraph YEARLY MAINTENANCE – REPLACING COMPONENTS.
109	Air in boiler circuit (temporary fault)	Check pump operation. Check the pump power input wiring.
110	Safety thermostat tripped due to overtemperature (pump probably blocked or air in heating circuit).	Check pump operation. Check the pump power input wiring Check that the limit thermostat is undamaged and replace it if necessary Check the continuity of the limit thermostat wiring
117	Pressure in hydraulic circuit too high (> 2.7 bar)	Check that the pressure in the system is correct See the FILLING THE SYSTEM section.
118	Pressure in hydraulic circuit too low	If the pressure in the CH circuit is < 0.5 bar, perform filling (see the FILLING THE SYSTEM section). Check the hydraulic pressure switch works correctly
125	No circulation safety trip. (control performed via a temperature sensor)	See the actions indicated in E109
128	No flame	Check the flame sensing electrode is in good condition and correctly positioned (see the ANNUAL SERVICING - POSITIONING THE ELECTRODES section). Check the wire is uninterrupted and makes good contact with the flame sensing electrode and the ignition switch. See the actions indicated in E92
129	Loss of flame at ignition	Check the flame sensing electrode is in good condition and correctly positioned (see the ANNUAL SERVICING - POSITIONING THE ELECTRODES section). Check the wire is uninterrupted and makes good contact with the flame sensing electrode and the ignition switch. Check for any recirculation of fumes.
130	Fumes NTC tripped due to overtemperature	Check the heat exchange level of the water-fumes exchanger: possible insufficient circulation or presence of scale. Check the fumes NTC probe (***).
133	Ignition failure (5 attempts)	Check that the gas valve is open and there is no air in the gas supply circuit. Check the gas supply pressure. Check the wire is uninterrupted and makes good contact with the flame sensing electrode and the ignition switch. See the actions indicated in E92 Check correct operation of the condensate drainage.

<b>134</b>	Gas valve blocked	Check the gas supply pressure. Check the integrity and position of the sensing and ignition electrodes and their wiring (see the ANNUAL SERVICING - POSITIONING THE ELECTRODES section). If necessary, replace the electronic board.
<b>135</b>	Internal board error	Check the connections between the gas valve and the electronic board.
	Gas valve connection error	
<b>154</b>	Delivery/return probe control test	See the actions indicated in E109
<b>160</b>	Fan fault	Check correct operation of the fan. Check that the fan power supply wiring is connected to the electronic board.
<b>178</b>	Intervention of safety thermostat for excess temperature in low temperature system	Check correct operation of the pump and the water circulation in the low temperature system. Check the pump power input wiring.
<b>317</b>	<b>162</b> Incorrect power supply frequency	Check whether the incorrect electric power supply frequency is due to causes outside the boiler, in which case contact the power supply company.
<b>384</b>	<b>164</b> Parasite flame (internal error)	Check correct operation of the gas valve.
<b>385</b>	<b>165</b> Input voltage too low	Input voltage $V < 175V$ . Check whether the power supply reductions are due to reasons other than the boiler. If so, contact the electricity provider.

CH = central heating.

(\*) External Sensor: cold resistance value: approximately  $1\text{ k}\Omega$  @  $25^\circ\text{C}$  (resistance decreases as temperature rises).

(\*\*) NTC delivery, return and DHW sensor: cold resistance value: approximately  $10\text{ k}\Omega$  @  $25^\circ\text{C}$  (resistance decreases as temperature rises).

(\*\*\*) NTC fumes probe: cold resistance value: approximately  $20\text{ k}\Omega$  @  $25^\circ\text{C}$  (resistance decreases as temperature rises).



***In the event of a fault, the display backlighting indicates the error code. 5 reset attempts can be performed after which the boiler shuts down. Wait 15 minutes before attempting to reset the boiler again.***

## 16. ADJUSTMENT AND SAFETY DEVICES

The boiler has been designed in full compliance with European reference standards and in particular is equipped with the following:

- **Limit thermostat**

Thanks to a sensor placed on the CH flow line, this thermostat interrupts the flow of gas to the burner if the water in the primary circuit overheats.

 It is forbidden to disable this safety device

- **NTC fumes sensor**

This device is positioned on the fumes-water exchanger. The electronic board stops gas from flowing to the burner in case of over heating.

 It is forbidden to disable this safety device

- **Flame ionisation detector**

The flame sensing electrode guarantees safety of operation in case of gas failure or incomplete ignition of the main burner. In these conditions, the boiler blocks.

- **Hydraulic pressure switch**

This device allows the main burner to be ignited only if system pressure is higher than 0.5 bars.

- **Pump post-circulation**

The electronically-controlled pump post-circulation function lasts 3 minutes and is enabled, in the heating mode, if the ambient thermostat causes the main burner to go out.

- **Antifreeze device**

The electronic boiler management system includes an "antifreeze" function for the heating and DHW systems which, when flow temperature falls below 5° C, operates the burner until a flow temperature of 30° C is reached. This function is enabled when the boiler is switched on, the gas supply is open and the system is correctly pressurised.

- **Anti-block pump function**

If no heat demand is received in the heating and/or DHW modes for 24 consecutive hours, the pump will automatically start and operate for 10 seconds.

- **Three-way valve anti-blockage function**

If no heat demand is received for a period of 24 hours, the three-way valve performs a complete switching cycle.

- **Hydraulic safety valve (heating circuit)**

This device is set to 3 bar and is used for the heating circuit. Connect the safety valve to a drain trap. Do not use it to drain the heating circuit.

- **Heating pump pre-circulation**

In case of a heat demand in the heating mode, the appliance can pre-circulate the pump before the burner is ignited. This pre-circulation phase last from a few seconds to a few minutes, depending on the operating temperature and installation conditions.

## 17. PUMP CAPACITY/ HEAD

This is a high static head pump fit for installation on any type of single or double-pipe heating systems. The automatic air valve incorporated in the pump allows quick venting of the heating system.

### KEY TO PUMP CHARTS - "SECTION" E

<b>Q</b>	WATER FLOW RATE	<b>MIN</b>	Minimum speed of modulation
<b>H</b>	HEAD	<b>MAX</b>	Maximum speed of modulation

## 18. ANNUAL SERVICING



If the boiler was operating, wait for the combustion chamber and pipes to cool down.



Before commencing any maintenance operations, make sure the boiler is disconnected from the power supply. After servicing, reset the original operating parameters of the boiler if they were changed.



Do not clean the boiler with abrasive, aggressive and/or easily flammable substances (such as petrol, acetone, etc.).

To optimise boiler efficiency, carry out the following annual controls:

- Check the appearance and airtightness of the gaskets of the gas and combustion circuits. Replace any worn seals with new original spares;
- Check the state and correct position of the ignition and flame-sensing electrodes;
- Check the state of the burner and make sure it is firmly fixed;
- Check for any impurities inside the combustion chamber. Use a vacuum cleaner to do this;
- Check the pressure of the heating system;
- Check the pressure of the expansion vessel;
- Check the fan works correctly;
- Make sure the flue and air ducts are unobstructed;
- Check for any impurities inside the siphon (for condensation boilers);
- Check the magnesium anode, where present, for boilers fitted with storage boilers.



It is advisable not to use the service cap at the base to empty and clean the siphon. Remove the siphon from inside the boiler and clean it with a jet of water. Fill the siphon with clean water and put back in place, making sure that it is properly connected.

### 18.1 HYDRAULIC UNIT

For special areas, where the water is harder than 20 °F (1 °F = 10 mg calcium carbonate per litre of water), install a polyphosphate dispenser or an equivalent treatment system, compliant with current regulations.

LEGEND - "SECTION" F

<b>A</b>	DHW exchanger fixing screw
<b>B</b>	DHW priority sensor with filter
<b>C</b>	Boiler/system drain tap ( <b>C-1</b> & <b>C-2</b> : access to tap <b>C</b> - bottom of boiler)
<b>D</b>	Boiler / system filling tap
<b>E</b>	DHW temperature NTC probe
<b>F</b>	Heating circuit water pressure sensor

#### 18.1.1 CLEANING THE COLD WATER FILTER

The boiler is fitted with a cold water filter located on the hydraulic assembly ( **B** ). To clean, proceed as follows:

- Drain the domestic hot water system.
- Remove the nut on the DHW priority sensor unit
- Pull out the flow sensor and its filter.
- Remove any impurities.



When replacing and/or cleaning the O-rings on the hydraulic assembly, only use Molykote 111 as a lubricant, not oil or grease.

### 18.2 POSITIONING THE ELECTRODES

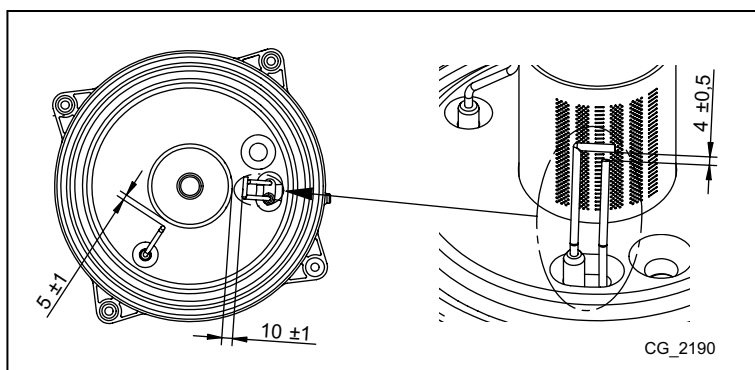

## 18.3 REPLACEMENT OF PARTS

If one or more of the following components are replaced:



- Water-fumes exchanger
- Fan
- Gas valve
- Gas nozzle
- Burner
- Flame sensing electrode

perform the Automatic Calibration procedure described below, then check and adjust the CO<sub>2</sub>% value as indicated in the section "COMBUSTION ADJUSTMENT FUNCTION (CO<sub>2</sub>%)".





*When working on the appliance, check the condition and position of the flame sensing electrode and replace it if necessary.*

### AUTOMATIC CALIBRATION FUNCTION



Press  and  together and hold down for at least 6 seconds. When the display indicates "On" press  (within 3 seconds after pressing the previous buttons).



*If the display indicates "303" the Automatic Calibration function has not been activated. Disconnect the boiler from the mains power supply for a few seconds and repeat the procedure.*

When the function is enabled,  and  flash on the display

After the ignition sequence, which can also take place after a few attempts, the boiler performs three operations (each lasting approximately 1 minute) going first to maximum power, then to ignition power and lastly to minimum power. Before moving on to the following phase (from maximum power to ignition power and then to minimum power), *P* and  appear on the display. During this phase, the power level reached by the boiler and the delivery temperature alternate on the display.

When ,  and  flash together on the display, the calibration function has terminated.

Press  to leave the function. The display shows **ESC**.

## 19. DISMANTLING, DISPOSAL AND RECYCLING



**Only qualified technicians are authorised to service the device and system.**

Before dismantling the appliance, make sure to have cut out the power supply, closed the gas inlet valve and secured all the boiler and system connections.

Dispose of the appliance correctly according to the laws and regulations in force. The appliance and accessories cannot be discarded along with normal household waste.

More than 90% of the materials that make up the appliance are recyclable.

## 20. TECHNICAL SPECIFICATIONS

Model: LUNA DUO-TEC E		1.12	1.24	1.28	24	28	33	40
Cat.		II <sub>2</sub> H3P						
Gas used	-	G20 - G31						
Rated heat input for DHW circuit.	kW	-	-	-	24,7	28,9	34,0	41,2
Rated heat input for heating circuit.	kW	12,4	24,7	28,9	20,6	24,7	28,9	33,0
Reduced heat input	kW	2,1	3,5	4,1	3,5	3,9	4,8	5,9
Rated heat output for DHW circuit	kW	-	-	-	24,0	28,0	33,0	40,0
Rated heat power 80/60 °C	kW	12,0	24,0	28,0	20,0	24,0	28,0	32,0
Rated heat power 50/30 °C	kW	13,1	26,1	30,5	21,8	26,1	30,6	34,9
Reduced heat output 80/60 °C	kW	2,0	3,4	4,0	3,4	3,8	4,7	5,7
Reduced heat output 50/30 °C	kW	2,2	3,7	4,3	3,7	4,1	5,1	6,3
Rated efficiency 50/30 °C	%	105,8	105,7	105,7	105,8	105,8	105,8	105,8
Max. pressure of water in heating circuit	bar	3						
Min. pressure of water in heating circuit	bar	0,5						
Capacity of water in expansion vessel	l	8	8	10	8	8	10	10
Minimum pressure of expansion vessel	bar	0,8						
Max. pressure of water in DHW circuit	bar	-	-	-	8,0	8,0	8,0	8,0
Min. dynamic pressure in DHW circuit	bar	-	-	-	0,15	0,15	0,15	0,15
Minimum flow of water in DHW circuit	l/min	-	-	-	2,0	2,0	2,0	2,0
Production of DHW with $\Delta T = 25$ °C	l/min	-	-	-	13,8	16,1	18,9	22,9
Production of DHW with $\Delta T = 35$ °C	l/min	-	-	-	9,8	11,5	13,5	16,4
Specific flow "D" (EN 13203-1)	l/min	-	-	-	11,5	13,4	15,8	19,1
Temperature range in heating circuit	°C	25+80						
Temperature range in DHW circuit	°C	35+60						
Fumes typology	-	C13 - C33 - C43 - C53 - C63 - C83 - B23						
Coaxial flue duct diameter	mm	60/100						
Diameter of separate outlets	mm	80/80						
Max. mass flow rate of fumes	kg/s	0,006	0,012	0,014	0,012	0,014	0,016	0,019
Min. mass flow rate of fumes	kg/s	0,001	0,002	0,002	0,002	0,002	0,002	0,003
Max. temperature of fumes	°C	75	80	80	80	80	80	80
NOx Class	-	6						
Natural gas supply pressure 2H	mbar	20						
Propane gas supply pressure 3P	mbar	37						
Power supply voltage	V	230						
Power supply frequency	Hz	50						
Rated power supply	W	72	85	99	85	99	106	120
Net weight	kg	34,5	34,5	36	38,5	38,5	39,5	41
Dimensions - height	mm	763						
- width	mm	450						
- depth	mm	345						
Protection-limit against humidity (EN 60529)	-	IPX5D						
EC certificate 0085CL0214								

### CONSUMPTION AT HEAT INPUT Q<sub>max</sub> and Q<sub>min</sub>

Q <sub>max</sub> (G20) - 2H	m <sup>3</sup> /h	1,31	2,61	3,06	2,61	3,06	3,60	4,36
Q <sub>min</sub> (G20) - 2H	m <sup>3</sup> /h	0,22	0,37	0,43	0,37	0,41	0,51	0,62
Q <sub>max</sub> (G31) - 3P	kg/h	0,96	1,92	2,25	1,92	2,25	2,64	3,20
Q <sub>min</sub> (G31) - 3P	kg/h	0,16	0,27	0,32	0,27	0,30	0,37	0,46

INSTALLER Section (en)

## 21. TECHNICAL PARAMETERS

BAXI LUNA DUO-TEC E			1.12	1.24	1.28	24	28	33	40
Condensing boiler			Yes	Yes	Yes	Yes	Yes	Yes	Yes
Low-temperature boiler <sup>(1)</sup>			No	No	No	No	No	No	No
B1 boiler			No	No	No	No	No	No	No
Cogeneration space heater			No	No	No	No	No	No	No
Combination heater			No	No	No	Yes	Yes	Yes	Yes
<b>Rated heat output</b>	<i>P<sub>rated</sub></i>	kW	12	24	28	20	24	28	32
Useful heat output at rated heat output and high temperature regime <sup>(2)</sup>	<i>P<sub>4</sub></i>	kW	12.0	24.0	28.0	20.0	24.0	28.0	32.0
Useful heat output at 30% of rated heat output and low temperature regime <sup>(1)</sup>	<i>P<sub>1</sub></i>	kW	4.0	8.0	9.4	6.7	8.0	9.4	10.7
<b>Seasonal space heating energy efficiency</b>	<i>η<sub>s</sub></i>	%	93	93	93	93	93	93	93
Useful efficiency at rated heat output and high temperature regime <sup>(2)</sup>	<i>η<sub>4</sub></i>	%	88.1	87.9	87.9	88.0	87.9	88.1	87.9
Useful efficiency at 30% of rated heat output and low temperature regime <sup>(1)</sup>	<i>η<sub>1</sub></i>	%	98.2	98.0	98.0	98.0	98.0	98.1	98.0
<b>Auxiliary electricity consumption</b>									
Full load	<i>el<sub>max</sub></i>	kW	0.030	0.042	0.047	0.030	0.042	0.041	0.035
Part load	<i>el<sub>min</sub></i>	kW	0.013	0.013	0.013	0.013	0.013	0.013	0.013
Standby mode	<i>P<sub>SB</sub></i>	kW	0.003	0.003	0.003	0.003	0.003	0.003	0.003
<b>Other items</b>									
Standby heat loss	<i>P<sub>stby</sub></i>	kW	0.035	0.035	0.040	0.035	0.035	0.040	0.045
Ignition burner power consumption	<i>P<sub>ign</sub></i>	kW	0.000	0.000	0.000	0.000	0.000	0.000	0.000
Annual energy consumption	<i>Q<sub>HE</sub></i>	GJ	37	74	87	62	74	87	99
Sound power level, indoors	<i>L<sub>WA</sub></i>	dB	52	52	53	49	50	53	51
Emissions of nitrogen oxides	NO <sub>x</sub>	mg/kWh	21	16	16	15	17	15	24
<b>Domestic hot water parameters</b>									
<b>Declared load profile</b>						XL	XL	XXL	XXL
Daily electricity consumption	<i>Q<sub>elec</sub></i>	kWh				0.162	0.232	0.214	0.276
Annual electricity consumption	<i>AEC</i>	kWh				36	51	47	61
<b>Water heating energy efficiency</b>	<i>η<sub>wh</sub></i>	%				88	86	87	85
Daily fuel consumption	<i>Q<sub>fuel</sub></i>	kWh				21.780	22.470	27.820	28.050
Annual fuel consumption	<i>AFC</i>	GJ				17	17	22	22
(1) Low temperature means for condensing boilers 30°C, for low temperature boilers 37°C and for other heaters 50°C return temperature (at heater inlet).									
(2) High temperature regime means 60°C return temperature at heater inlet and 80°C feed temperature at heater outlet.									



## 22.PRODUCT FICHE

BAXI LUNA DUO-TEC E		1.12	1.24	1.28	24	28	33	40
Space heating - Temperature application		Medium	Medium	Medium	Medium	Medium	Medium	Medium
Water heating - Declared load profile					XL	XL	XXL	XXL
Seasonal space heating energy efficiency class		A	A	A	A	A	A	A
Water heating energy efficiency class					A	A	A	A
Rated heat output ( <i>Prated or Psup</i> )	kW	12	24	28	20	24	28	32
Space heating - Annual energy consumption	GJ	37	74	87	62	74	87	99
Water heating - Annual energy consumption	kWh <sup>(1)</sup>				36	51	47	61
	GJ <sup>(2)</sup>				17	17	22	22
Seasonal space heating energy efficiency	%	93	93	93	93	93	93	93
Water heating energy efficiency	%				88	86	87	85
Sound power level L <sub>WA</sub> indoors	dB	52	52	53	49	50	53	51
(1) Electricity (2) Fuel								

	it	en	de	cs	sk
1	Pompa con separatore d'aria	Pump with air separator	Pumpe mit Luftabscheidung	Čerpadlo se separátorem vzduchu	Čerpadlo so separátorom vzduchu
2	Rubinetto di scarico caldaia	Boiler drain tap	Entleerungshahn Heizkessel	Vypouštěcí ventil kotle	Vypouštěcí ventil kotla
3	Manometro	Pressure gauge	Druckmesser	Manometr	Manometer
4	Valvola di sicurezza idraulica	Hydraulic Safety valve	Hydraulisches Sicherheitsventil	Bezpečnostní hydraulický ventil	Bezpečnostný hydraulický ventil
5	Rubinetto di caricamento impianto	Boiler filling tap	Hahn zum Anfüllen der Anlage	Napouštěcí ventil systému	Napouštěcí ventil systému
6	Sensore di flusso con filtro e limitatore di portata	Flow sensor with water filter and flow limiting device	Flusssensor mit Filter und Durchflussbegrenzer	Snímač proudění s filtrem a omezovačem průtoku	Snímač průdenia s filtrom a omezovačom prietoku
7	Sensore di precedenza sanitaria	DHW priority sensor	Warmwasser-Vorrangfühler	Snímač přednosti TUV	Prednostný snímač TUV
8	Sonda NTC sanitaria	NTC DHW sensor	NTC-Fühler Sanitärwasser	Sonda NTC TUV	Sonda NTC TUV
9	Sensore di pressione idraulico	Hydraulic Pressure Sensor	Hydraulikdruckfühler	Hydraulický tlakový snímač	Snímač hydraulického tlaku
10	Valvola 3 vie motorizzata	3-way valve with motor	Motorisiertes Dreiwegeventil	Trojcestný motorizovaný ventil	Trojcestný motorizovaný ventil
11	Valvola di non ritorno	Non-return valve	Rückschlagventil	Zpětný ventil	Spätňý ventil
12	Scambiatore sanitario	DHW heat exchanger	Warmwassertaustauscher	Výměník TUV	Výmenník TUV
13	Valvola gas	Gas valve	Gasventil	Plynový ventil	Plynový ventil
14	Termostato di sicurezza	Safety thermostat	Sicherheitsthermostat	Bezpečnostní termostat	Bezpečnostný termostat
15	Sonda NTC riscaldamento	NTC heating sensor (flow/return)	NTC-Fühler Heizung	Sonda topení NTC	Sonda NTC vykurovania
16	Sonda fumi	Fumes sensor	Abgasfühler	Sonda spalin	Sonda spalin
17	Raccordo coassiale	Coaxial connector	Koaxiales Anschlussstück	Koaxiální spoj	Koaxiálny spoj
18	Scambiatore acqua-fumi	Water-fumes exchanger	Wasser-Abgas-Austauscher	Výměník voda-spaliny	Výmenník voda-spaliny
19	Elettrodo di accensione	Ignition electrode	Zündungselektrode	Zapalovací elektroda	Zapalovacia elektroda
20	Brucciato	Burner	Brenner	Hořák	Horák
21	Elettrodo di rivelazione di fiamma	Flame detection electrode	Flammenüberwachungselektrode	Kontrolní elektroda plamene	Kontrolná elektroda plameňa
22	Collettore miscela aria-gas	Air/gas blend manifold	Sammelrohr Luft-/Gasgemisch	Kolektor směsi vzduch-plyn	Kolektor zmesi vzduch-plyn
23	Ventilatore	Fan	Ventilator	Ventilátor	Ventilátor
24	Venturi	Venturi	Venturi	Venturiho trubice	Venturiho trubica
25	Vaso di espansione	Expansion vessel	Expansionsgefäß	Expanzní nádoba	Expanzná nádoba
26	By-pass automatico	Automatic by-pass	Automatischer By-pass	Automatický by-pass	Automatický by-pass
27	Rubinetto di caricamento con valvola di non ritorno	Boiler filling tap with non-return valve	Hahn zum Anfüllen mit Rückschlagventil	Napouštěcí ventil se zpětným ventilem	Napouštěcí ventil so spätňým ventilem
A	Sifone con scarico condensa	Siphon with condensate drain	Siphon mit Kondenswasserablass	Sifon s vypuštěním kondenzace	Sifón s vypúšťaním kondenzácie
B	Rubinetto mandata acqua di riscaldamento	Heating flow tap	Hahn des Heizwasservorlaufs	Přívodní ventil vody vytápění	Prívodný ventil vody vykurovania
C	Uscita acqua calda sanitaria/Bollitore	DHW outlet/Storage boiler	Wasserabfluss warmes Sanitärwasser/Boiler	Výstup teplé vody TUV/bojler	Vypustenie teplej vody TUV/bojlera
D	Rubinetto ingresso GAS	Gas inlet tap	GAS-Zuflusshahn	Vstupní ventil PLYN	Vstupný ventil PLYNU
E	Rubinetto ingresso acqua fredda sanitaria	Cool DHW inlet tap	Zuflusshahn für kaltes Sanitärwasser	Vstupní ventil studené vody TUV	Vstupný ventil studenej vody TUV
F	Rubinetto ritorno acqua riscaldamento	Heating return tap	Rücklaufhahn Heizwasser	Zpětný ventil vody topení	Spätňý ventil vykurovanej vody



	it	en	de	cs	sk
1	Fusibili	Fuses	Schmelzsicherungen	Pojistky	Pojistky
2	Alimentazione elettrica 230 V	230 V Power Supply	Stromversorgung 230 V	Napájecí síť	Napájecia sieť
3	Termostato Ambiente (TA)	Room Thermostat (RT)	Raumthermostat (RT)	Prostorový termostat (PT)	Priestorový termostat (PT)
4	Ventilatore	Fan	Ventilator	Ventilátor	Ventilátor
5	Termostato di sicurezza	Safety Thermostat	Sicherheitsthermostat	Bezpečnostní termostat	Bezpečnostný termostat
6	Valvola gas	Gas valve	Gasventil	Plynová armatura	Plynová armatúra
7	Sensore di precedenza sanitario	DHW priority sensor	Warmwasser-Vorrangsensor	Čidlo přednosti TUV	Čidlo přednosti TUV
8	Sonda fumi	Fumes sensor	Abgasfühler	Sonda spalin	Sonda spalin
9	Sensore di pressione	Water pressure sensor	Drucksensor	Tlakový spínač	Tlakový spínač
10	Sonda ritorno riscaldamento	Heating return sensor	Rücklauffühler Heizung	Sonda zpátečky topeni	Sonda spätočky kúrenia
11	Sonda mandata riscaldamento	Heating flow sensor	Vorlauffühler Heizung	Sonda vstupu topeni	Sonda vstupu kúrenia
12	Sonda NTC sanitaria	NTC DHW sensor	NTC-Fühler Warmwasser	Sonda NTC TUV	Sonda NTC TUV
13	Collegamento accessori	Accessories connection	Anschluss des Zubehörs	Ovládací panel (na stěně)	Ovládací panel (na stene)
14	Sonda esterna	Outdoor sensor	Außentemperaturfühler	Vnější sonda	Vonkajšia sonda
15	Elettrodo di rivelazione fiamma	Flame sensor electrode	Flammenüberwachungselektrode	Kontrolní elektroda plamene	Kontrolná elektroda plameňa
16	Elettrodo di accensione	Ignition electrode	Zündungselektrode	Zapalovací elektroda	Zapaľovacia elektroda
17	Valvola 3-vie motorizzata	Diverter valve motor	Motorisiertes Dreiwegeventil	Trojcestný ventil	Trojcestný ventil
18	Pompa	Pump	Pumpe	Čerpadlo	Čerpadlo
C	Celeste	Blue	Heilblau	Modrá	Modrá
M	Marrone	Brown	Braun	Hnědá	Hnědá
N	Nero	Black	Schwarz	Černá	Čierna
R	Rosso	Red	Rot	Červená	Červená
G/V	Giallo/Verde	Yellow/Green	Grüngelb	Žlutá/Zelená	Žltá/Zelená
V	Verde	Green	Grün	Zelená	Zelená
B	Bianco	White	Weiß	Bílá	Biela
G	Grigio	Grey	Grau	Šedá	Šedá
Y	Giallo	Yellow	Gelb	Žlutá	Žltá
P	Viola	Violet	Violett	Fialová	Fialová



	it	en	de	cs	sk
1	Fusibili	Fuses	Schmelzsicherungen	Pojistky	Pojistky
2	Alimentazione elettrica 230 V	230 V Power Supply	Stromversorgung 230 V	Napájecí síť 230 V	Napájecí sieť 230 V
3	Termostato Ambiente (TA)	Room Thermostat (RT)	Raumthermostat (RT)	Prostorový termostat (PT)	Priestorový termostat (PT)
4	Ventilatore	Fan	Ventilator	Ventilátor	Ventilátor
5	Termostato di sicurezza	Safety Thermostat	Sicherheitsthermostat	Bezpečnostní termostat	Bezpečnostný termostat
6	Valvola gas	Gas valve	Gasventil	Plynová armatura	Plynová armatúra
7	Sonda fumi	Fumes sensor	Abgasfühler	Sonda spalin	Sonda spalin
8	Sensore di pressione	Water pressure sensor	Drucksensor	Tlakový spínač	Tlakový spínač
9	Sonda ritorno riscaldamento	Heating return sensor	Rücklauffühler Heizung	Sonda zpátečky topení	Sonda spiatocky kúrenia
10	Sonda mandata riscaldamento	Heating flow sensor	Vorlauffühler Heizung	Sonda vstupu topení	Sonda vstupu kúrenia
11	Collegamento accessori	Accessories connection	Anschluss des Zubehörs	Ovládací panel (na stěně)	Ovládací panel (na stene)
12	Sonda esterna	Outdoor sensor	Außentemperaturfühler	Vnější sonda	Vonkajšia sonda
13	Sonda NTC bollitore sanitario	Boiler NTC DHW sensor	NTC-Fühler Warmwasserspeicher	Sonda NTC esterno/riserbovniku	Sonda NTC externého zásobníka
14	Elettrodo di rivelazione fiamma	Flame sensor electrode	Flammenüberwachungselektrode	Kontrolní elektroda plamene	Kontrolná elektroda plameňa
15	Elettrodo di accensione	Ignition electrode	Zündungselektrode	Zapalovací elektroda	Zapalovacia elektroda
16	Valvola 3-vie motorizzata	Diverter valve motor	Motorisiertes Dreiwegeventil	Trojcestný ventil	Trojcestný ventil
17	Pompa	Pump	Pumpe	Čerpadlo	Čerpadlo
C	Celeste	Blue	Hellblau	Modrá	Modrá
M	Marrone	Brown	Braun	Hnědá	Hnědá
N	Nero	Black	Schwarz	Černá	Čierna
R	Rosso	Red	Rot	Červená	Červená
GM	Giallo/Verde	Yellow/Green	Grüngelb	Žlutá/Zelená	Žltá/Zelená
V	Verde	Green	Grün	Zelená	Zelená
B	Bianco	White	Weiß	Bílá	Biela
G	Grigio	Grey	Grau	Šedá	Šedá
Y	Giallo	Yellow	Gelb	Žlutá	Žltá
P	Viola	Violet	Violett	Fialová	Fialová

SECTION C

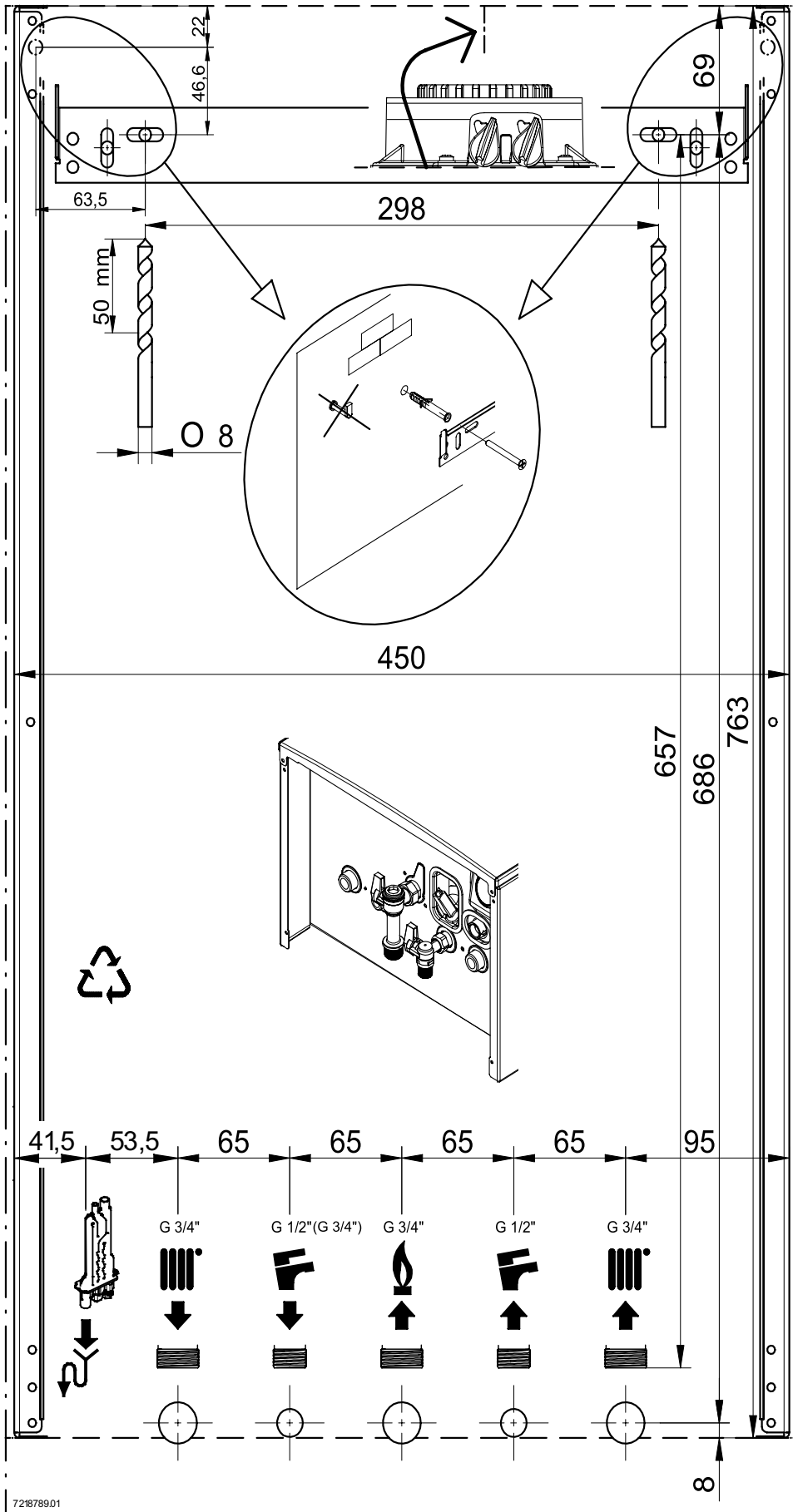



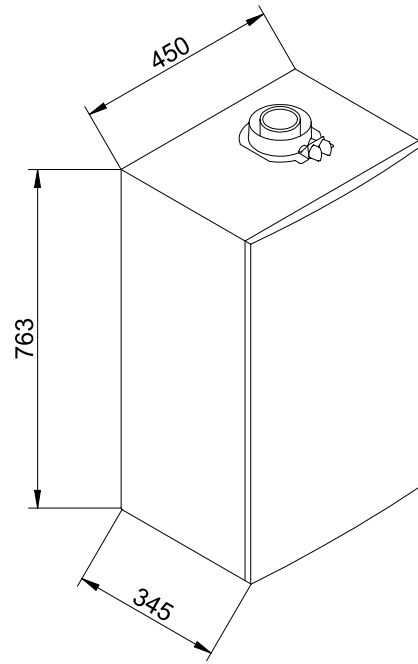

1.12 - 1.24 - 1.28

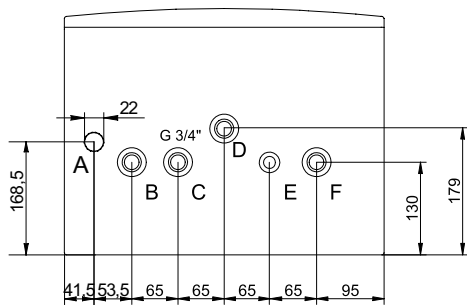

24 - 28 - 33 - 40

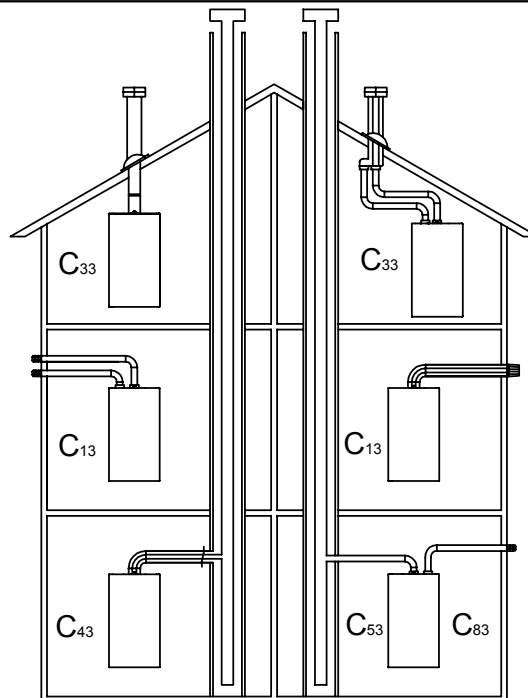
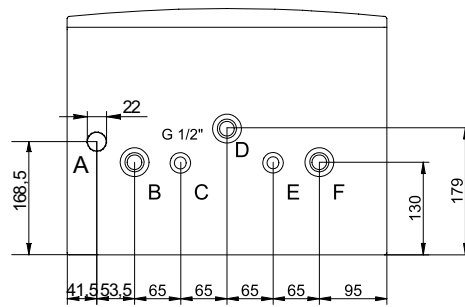

CG\_1638

SECTION D

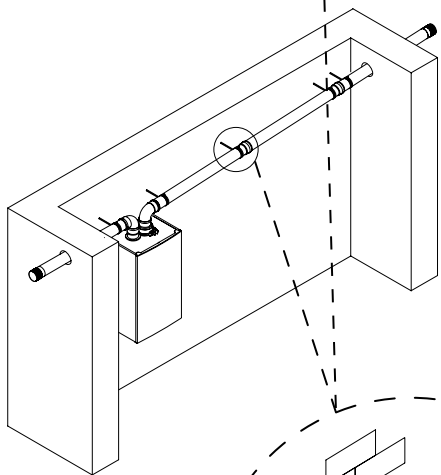
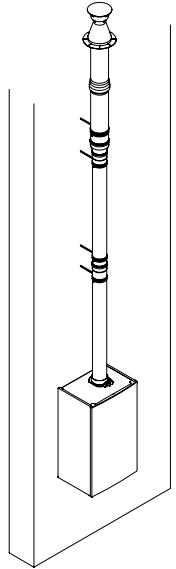
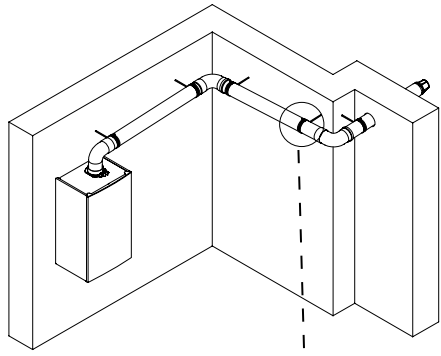

CG\_2275

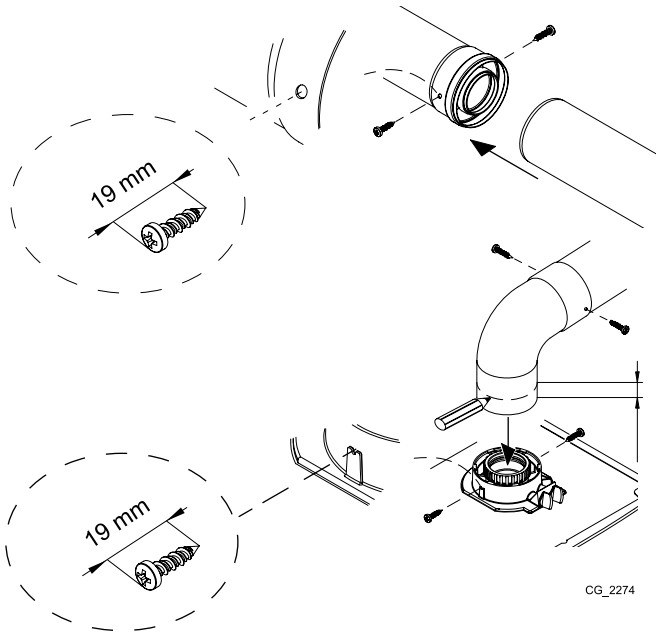
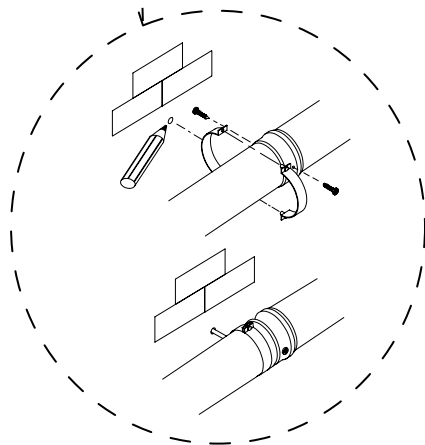

CG\_2274

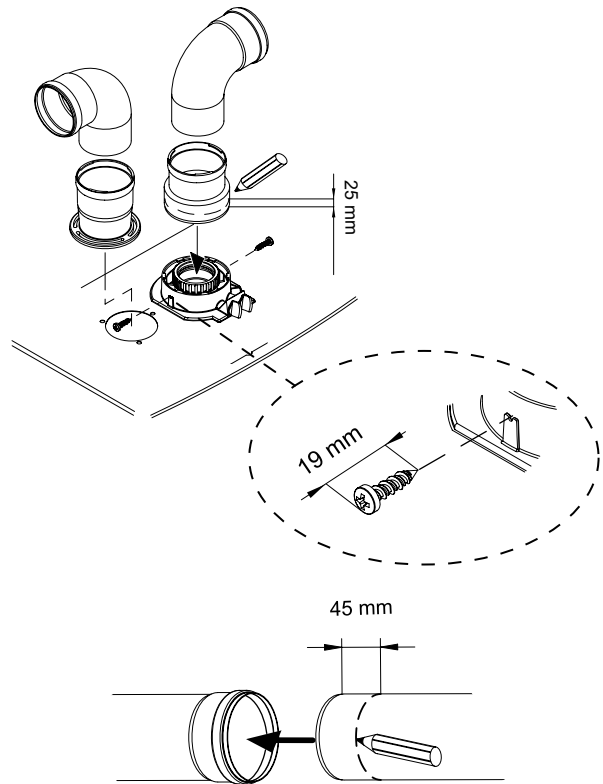
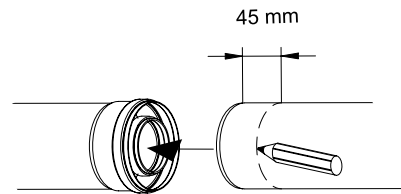

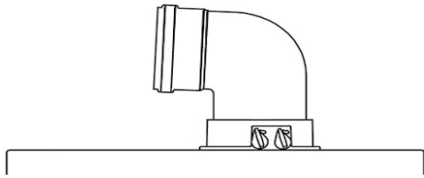

<b>A B</b>	Lmax = 10 m - Ø 60/100 mm
	Lmax = 25 m - Ø 80/125 mm
<b>C D</b>	Lmax = 9 m - Ø 60/100 mm
	Lmax = 24 m - Ø 80/125 mm
<b>E</b>	Lmax = 10 m - Ø 60/100 mm
	Lmax = 25 m - Ø 80/125 mm
<b>F G</b>	Lmax = 10 m - Ø 60/100 mm
	Lmax = 25 m - Ø 80/125 mm
<b>H</b>	Lmax = 8 m - Ø 60/100 mm
	Lmax = 23 m - Ø 80/125 mm
<b>I</b>	Lmax = 9 m - Ø 60/100 mm
	Lmax = 24 m - Ø 80/125 mm

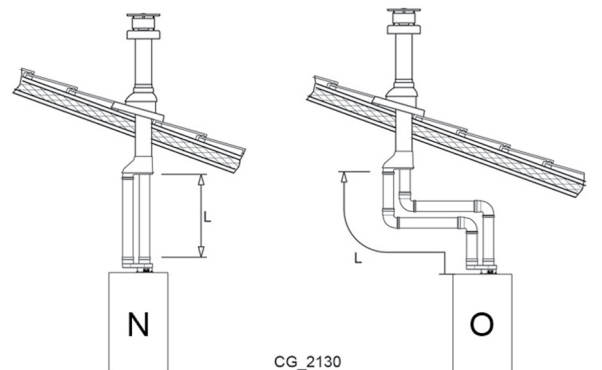
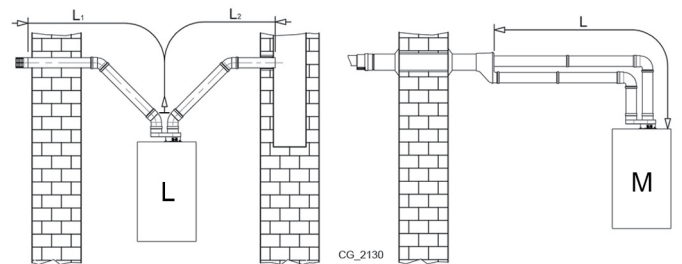
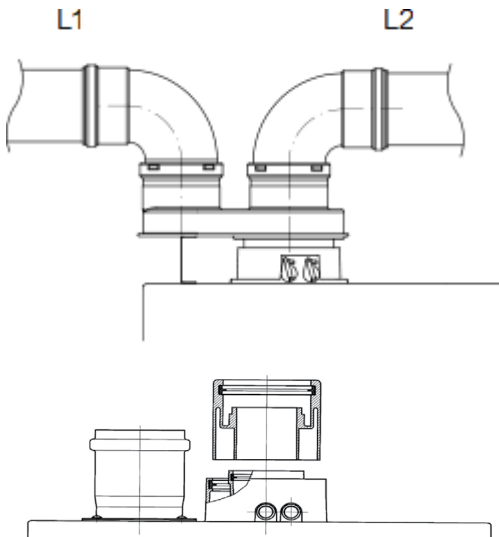
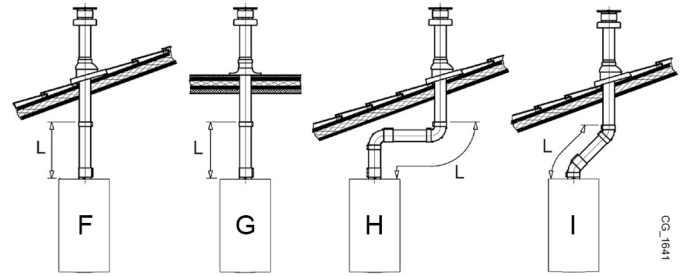
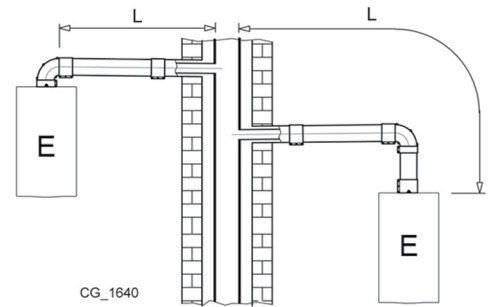
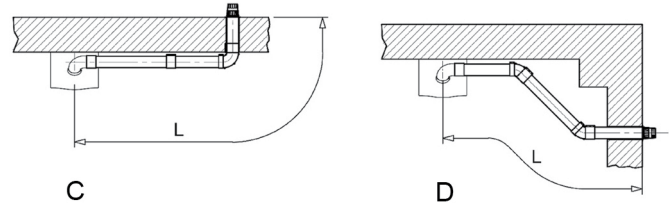
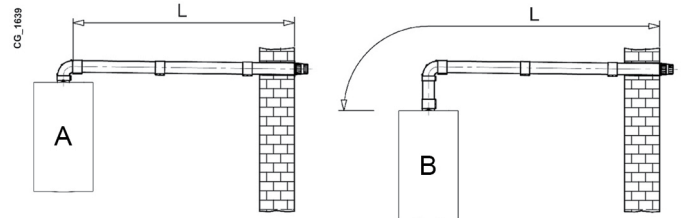

<b>L</b>	(L1+L2) max = 80 m - Ø 80 mm L1 max = 15 m
<b>M</b>	L max = 15 m
<b>N</b>	L max = 15 m
<b>O</b>	L max = 14 m

SECTION D

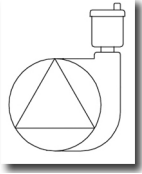

LUNA DUO-TEC E 1.12 - 1.24 - 24 - 28 - 33

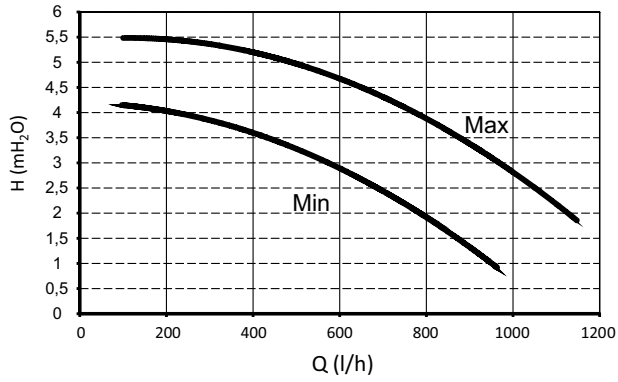

LUNA DUO-TEC E 1.28 - 40

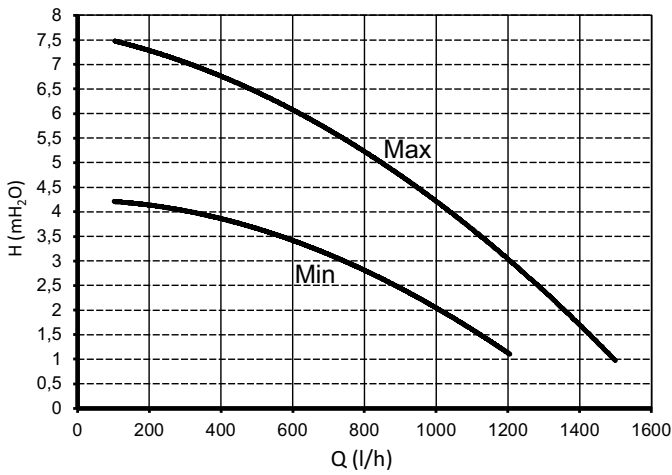

SECTION E

SIEMENS QAC34

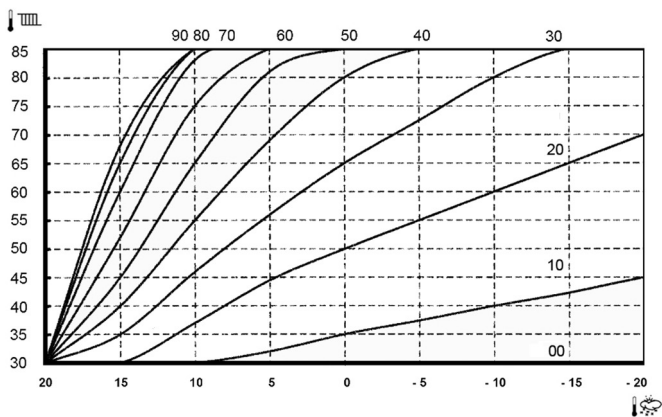

A

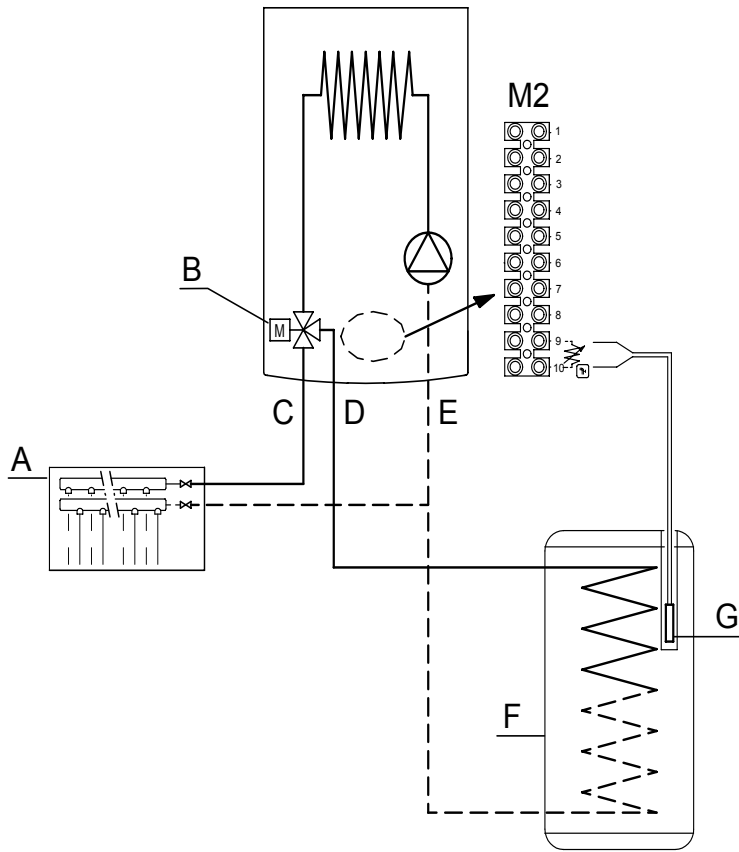

CG\_2171

B

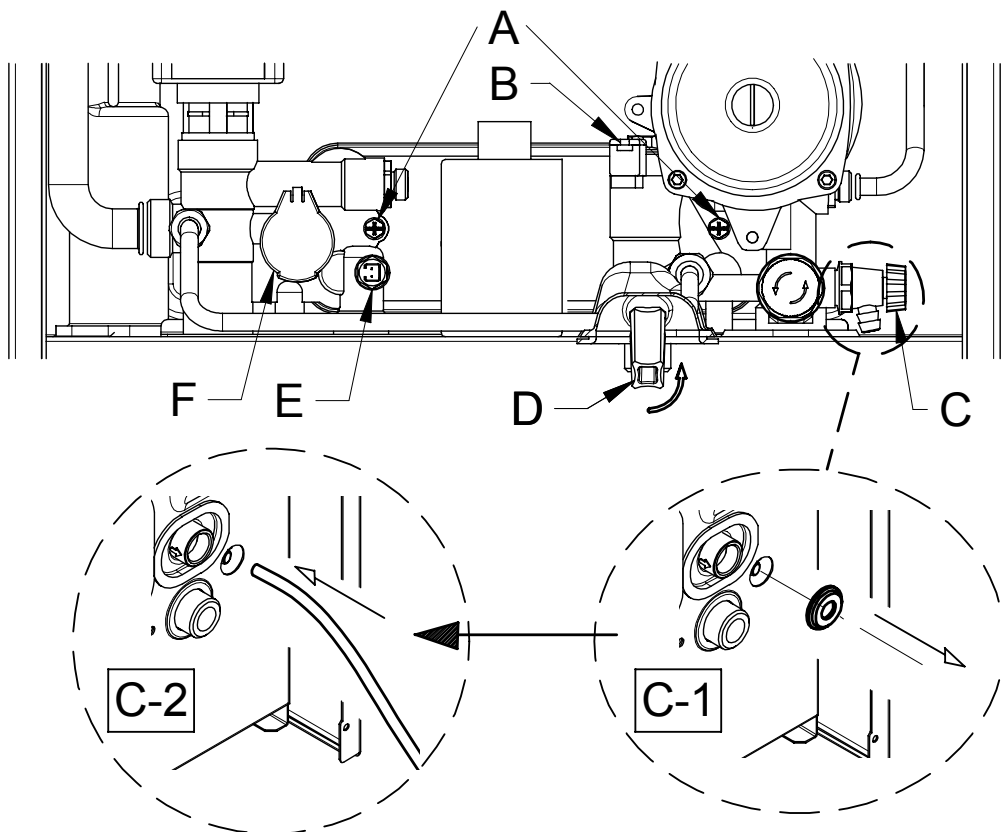

CG\_2200

SECTION F

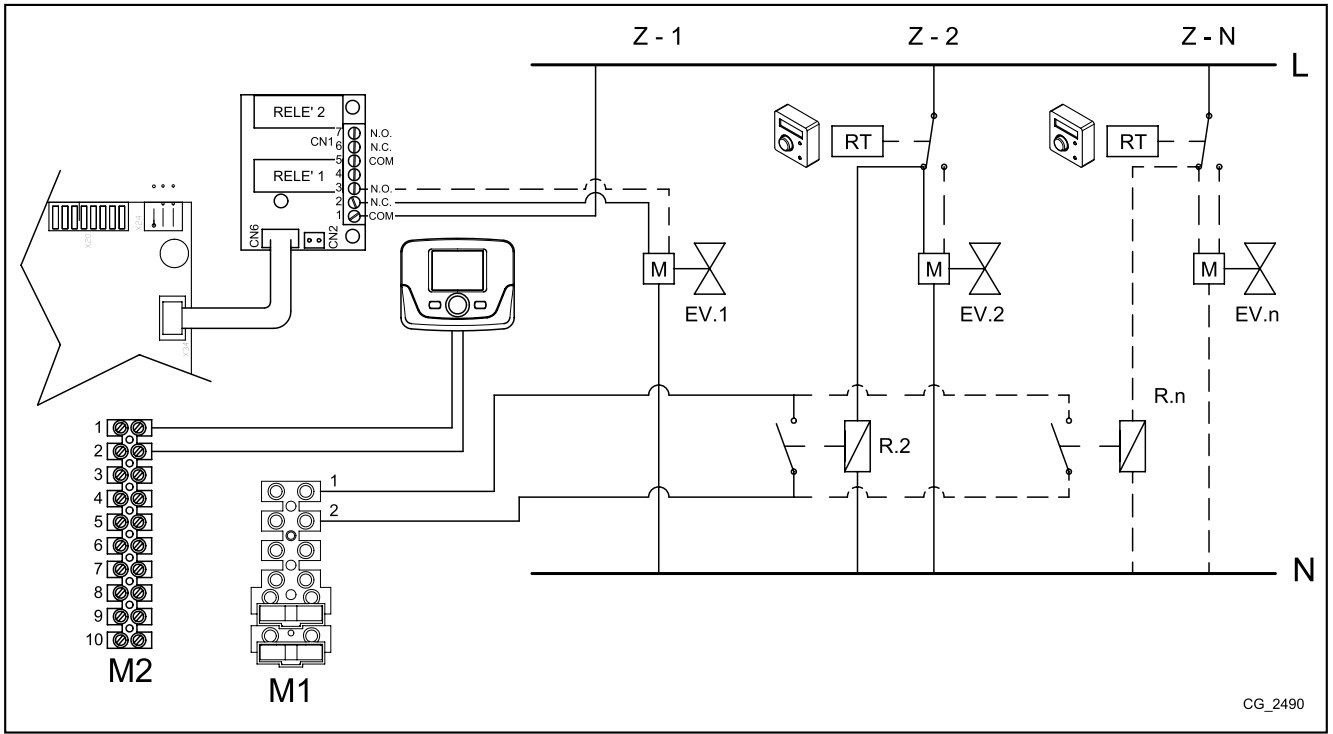

CG\_2490









**BAXI**

*36061 Bassano del Grappa (VI) - ITALIA*

*Via Trozzetti, 20*

*Servizio clienti: tel. 0424-517800 – Telefax 0424-38089*

*[www.baxi.it](http://www.baxi.it)*