

MCCH

INSTALLATION

MODULAR CEILING. COOLING AND HEATING.

ModuleCeiling.

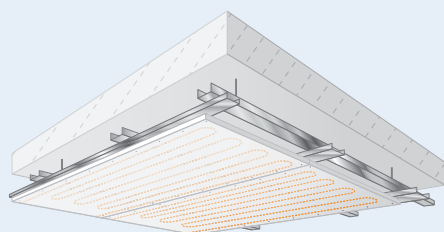
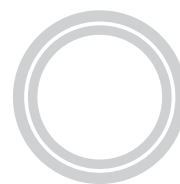

Classic.

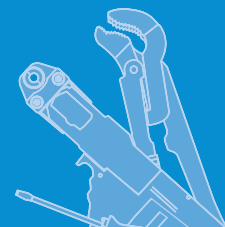
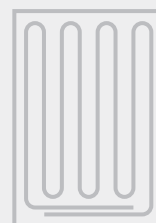

Acoustic.

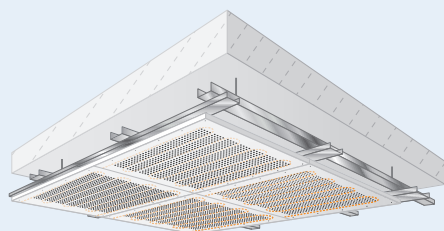

PDF



1. Safety information	3
1.1 General.....	3
1.2 Guarantee conditions	3
1.3 Maximum flow temperature and dew point.....	3
1.4 Humidity.....	3
1.5 Fire protection	3
1.6 Load bearing wall.....	3
1.7 Visible side/rear side of the ModulePanel.....	3
1.8 Standards.....	3
1.9 ModulePanels storage	4
1.10 Variomodular pipe 11.6x1.5 Laser (in ModulePanel)	4
1.11 Storage of pre-insulated Variomodular pipe 16x2 Laser.....	4
2. Preparation	5
2.1 Tools.....	5
2.2 Other work documents.....	5
3. Substructure	6
3.1 General.....	6
3.2 Dimensions in border area.....	6
3.3 Main joists/main profiles.....	6
3.4 Cross joists/cross profiles.....	8
3.5 Directly fastened cross joists (variant without main joists)	8
4. ModulePanels	9
4.1 ModulePanels-Acoustic – Overview.....	9
4.2 ModulePanels-Acoustic – Fastening area.....	9
4.3 ModulePanels-Classic – Overview.....	10
4.4 ModulePanels-Classic – Fastening area.....	11
4.5 Installing the ModulePanels	12
4.6 Movement joints	14
4.7 Fitting dew-point controller	14
4.8 ModuleExpansionPanels	15
4.9 Panel transitions	15
4.10 Transitions from ModulePanels to other panel materials.....	15
4.11 Installation of panels between installed ModulePanels	16
4.12 Ceiling elements.....	17
4.13 Insulation with ModulePanels-Acoustic	17
4.14 Hydraulic connection & pressing.....	18
5. Surface	20
5.1 Stopping	20
5.2 Fastening loads to the ModuleCeiling	20
5.3 Painting.....	20
6. Protocols	21
6.1 Leak-tightness test.....	21
6.2 Preheating Protocol.....	21

1.1 General

These installation instructions are intended for authorised specialist personnel. Local, geographical and climatic regulations/standards for cooling, heating and electrical installations must be observed!

1.2 Guarantee conditions

If the heating system is installed or commissioned incorrectly, all claims on the basis of the manufacturer's warranty and guarantee become void. Our currently applicable installation instructions are an integral part of our guarantee!

1.3 Maximum flow temperature and dew point

Heating: The maximum flow temperature for the ModulePanels is 50 °C. For reasons of comfort, do not exceed $t_{mH} = 35$ °C ($t_i/t_r = 40/30$ °C) with the ModuleCeiling.

Cooling: The flow temperature must be selected or ensured in such a way that the surface temperature of the ModulePanel (both on the room side and in the cavity) and the pipe never reaches or falls below the dew-point temperature at any point. Condensation can form on the pipes and surfaces if the flow temperature selected is too low. Control precautions must be taken to prevent this (e.g. dew-point controller, see section 4.7).

1.4 Humidity

The relative humidity must not exceed 70 % during storage, installation and additional processing of the ModulePanels and during the construction phase and normal use of the building. Wet plaster and wet screed must be applied and have dried before installation of the ModulePanels.

The ModulePanels can be used in rooms up to moisture class W3 (ÖNORM B 3407). They are not approved for installation from moisture class W4 (e.g. canteens and shower blocks) upwards.

1.5 Fire protection

From a fire protection perspective, the 18 mm Variotherm ModulePanels correspond to a 12.5 mm FERMACELL Gypsum fibre-board panel (Test IBS-Linz No. VFA2001-0389.01, fire protection assessment file number 10111710). Please observe the corresponding FERMACELL regulations and FERMACELL fire protection assessments. The Variotherm **ModulePanels-Acoustic** provide no fire protection!

1.6 Load bearing wall

Low "static" single loads up to 2 kg (max. 6 kg/m²) can be fixed directly on the ModuleCeiling (see chapter 5.2). Heavier suspended elements must only be attached to the substructure and not to the ModulePanels. These loads are to be taken into account when installing the substructure (see chapter 3).

1.7 Visible side/rear side of the ModulePanel

The visible side of the ModulePanel (the smooth side) faces into the room and the rear side (with the integrated Variomodular pipe) faces the substructure.

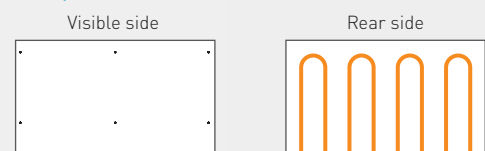

1.8 Standards

The validity of the standards specified in these installation instructions was last verified on 16 January 2020!

If necessary, amendments to standards must be checked!



1.9 ModulePanels storage

The ModulePanel are gypsum fibreboard 18 mm with a pre-integrated Variomodular pipe 11.6x1.5 Laser (aluminium multi-layer composite pipe)

The ModulePanels are supplied on pallets.

When storing the ModulePanel pallets, you should ensure that the storage area can support them.

Each ModulePanel weighs 20.5 kg/m².

The ModulePanels must be laid flat on a level surface.

They should be protected from moisture. Panels that have become damp for a short time should only be used after they have completely dried out.

If they are re-stacked during transport on the building site, the visible side of the ModulePanels should be laid so that they face downwards.

Vertical storage deforms the panels and damages the edges. It is possible to transport the panels horizontally inside the building with a lift truck or other panel transportation vehicle.

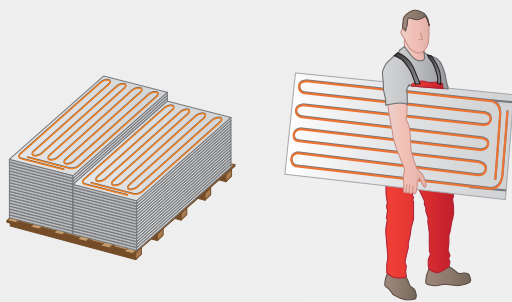
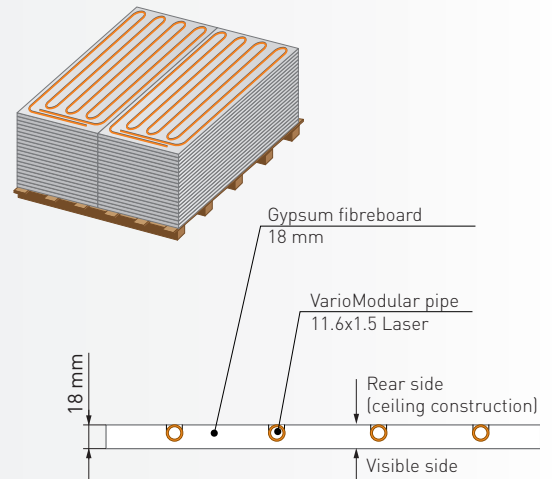

<< It is best to carry individual ModulePanels vertically.

1.10 Variomodular pipe 11.6x1.5 Laser (in ModulePanel)

The Variomodular pipe 11.6x1.5 Laser is an aluminium multi-layer composite pipe (100 % oxygen diffusion-tight). It is pre-integrated in the ModulePanels.

In order to prevent the Variomodular pipe from being damaged by drilling or chiselling during the construction phase, high-visibility warning signs should be placed at appropriate locations.

In terms of weather resistance, the same instructions apply to the Variomodular pipe 11.6x1.5 Laser as to the pre-insulated Variomodular pipe 16x2.

1.11 Storage of pre-insulated Variomodular pipe 16x2 Laser

The pre-insulated Variomodular pipe is an aluminium multi-layer composite pipe (100 % oxygen diffusion-tight) which includes insulation.

Damage (e.g. denting and scratching) is to be avoided during storage, transport, unloading, unwinding and laying. This type of damage has a detrimental effect on the creep behaviour.

In order to prevent damage to the Variomodular pipe during the construction phase, high-visibility warning signs should be placed at appropriate locations.

The interaction of the air's oxygen with UV rays damages the pipes, which should not be stored in the open air. Normal temporary storage on the construction site for a few days is permissible.

At low temperatures (≤ 5 °C) the Variomodular pipe should be stored in heated rooms prior to processing.



2.1 Tools

Tools for installing the ModulePanels to the substructure (on-site):

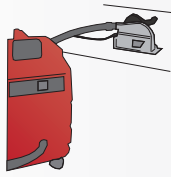

Circular saw with vacuum attachment

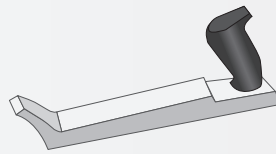

Plane for visible edges

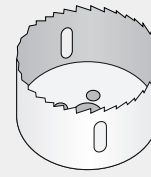

Hole saw



Ceiling supports



Ladder



Power screw gun, preferable with latching depth stop



Cartridge gun for joint adhesive

Tools for stopping the ModulePanel seams:



Clean buckets

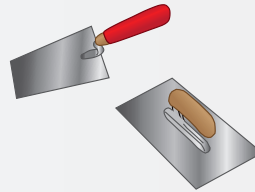

Trowel and plastering knife

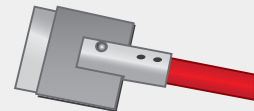

Adhesive scraper

Variotherm tools for connecting the Variotherm pipes:

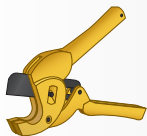

Pipe cutting pliers



Calibration and chamfering tool

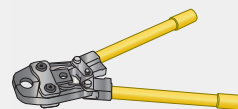

EcoPress or AkkuPress Mini pressing tool, incl. press-fitting jaws



2.2 Other work documents

Please also follow up-to-date FERMACELL planning and installation instructions!

Fermacell -
Planning and preparationFermacell -
Processing instructionsVariotherm -
Distribution and control

3.1 General

This chapter shows possible substructures for the ModulePanels and special issues to be noted before and during installation of the ModulePanels. Independently of this, please observe the planning and installation guidelines of the manufacturer of the wooden or drywall system used for your ceiling construction.

With wooden constructions, the timber used must be sufficiently dry and straight, and conform to the Austrian standard DIN 4074-1 (quality class 2 and cutting class S = sharp-edged).

With metal constructions, the profiles must be made of soft, non-alloyed steel with double-sided galvanising of at least 100 g/m² according to the Austrian standard DIN 18 182-1 or DIN EN 14 195.

Before installing the ModulePanels it must be ensured that the construction is designed to carry the weight of the ModulePanels (20.5 kg/m²) and any eventual additional loads (e.g. ceiling lights).

Caution: Do not glue the ModulePanels directly to the ceiling (plaster).

Additional loads such as ceiling lights, multi-layer planking and other fittings must also be taken into account! These must not be directly hung on the ModulePanel.

3.2 Dimensions in border area

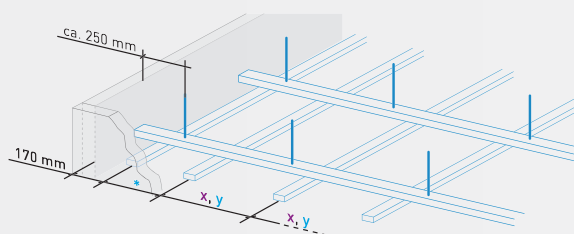

* ... (x or y) minus 170 mm

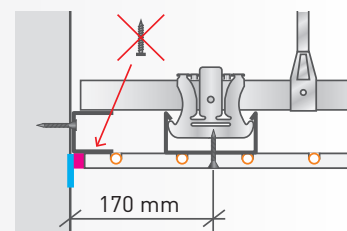

3.3 Main joists/main profiles

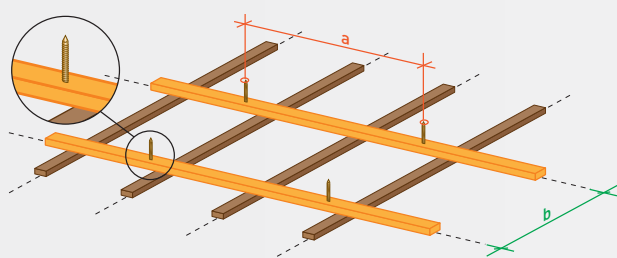

3.3.1 Wooden substructure:
Directly fastened
main joists.

	Joist dimensions w × h [mm]	Max. permissible span for loads of up to 30 kg/m ² \triangleq ModulePanel (20.5 kg/m ²) + light additional load (up to 9.5 kg/m ²)	Max. permissible span for loads of up to 50 kg/m ² \triangleq ModulePanel (20.5 kg/m ²) + heavy additional load (up to 29.5 kg/m ²)
Max. clearance direct attachment (a)	Main joists 48 × 24	650 mm	600 mm
	Main joists 50 × 30	750 mm	600 mm
	Main joists 60 × 40	850 mm	700 mm
Max. axis clearance main joists (b)	Cross joists 48 × 24	600 mm	500 mm
	Cross joists 50 × 30	750 mm	600 mm
	Cross joists 60 × 40	1000 mm	900 mm

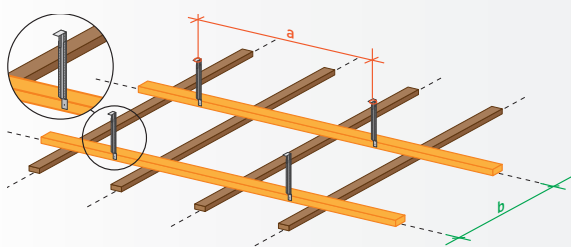

3.3.2 Wooden substructure: suspended main joists

	Joist dimensions w × h [mm]	Max. permissible span for loads of up to 30 kg/m ² \triangleq ModulePanel (20.5 kg/m ²) + light additional load (up to 9.5 kg/m ²)	Max. permissible span for loads of up to 50 kg/m ² \triangleq ModulePanel (20.5 kg/m ²) + heavy additional load (up to 29.5 kg/m ²)
Max. clearance suspension element (a)	Main joists 30 × 50 ¹⁾	850 mm	700 mm
	Main joists 40 × 60	1000 mm	850 mm
Max. axis clearance main joists (b)	Cross joists 48 × 24	600 mm	500 mm
	Cross joists 50 × 30	750 mm	600 mm
	Cross joists 60 × 40	1000 mm	900 mm

¹⁾ Only in conjunction with cross joists that are 50 mm wide and 30 mm high

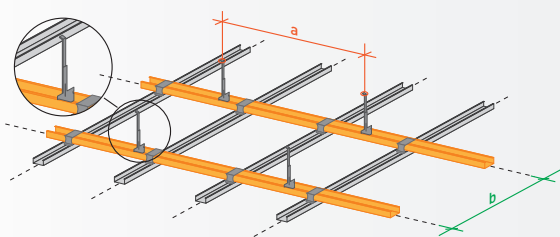

3.3.3 Metal substructure: suspended main profile

	Profile dimensions ²⁾ w × h [mm]	Max. permissible span for loads of up to 30 kg/m ² \triangleq ModulePanel (20.5 kg/m ²) + light additional load (up to 9.5 kg/m ²)	Max. permissible span for loads of up to 50 kg/m ² \triangleq ModulePanel (20.5 kg/m ²) + heavy additional load (up to 29.5 kg/m ²)
Max. clearance suspension element (a)	Main profile CD 60 × 27 × 06	750 mm	600 mm
Max. axis clearance main profile (b)	Cross profile CD 60 × 27 × 06	1000 mm	750 mm

²⁾ Standard steel sheet profiles (as per ÖNORM/DIN 18182 or ÖNORM/DIN EN 14195)

3.4 Cross joists/cross profiles

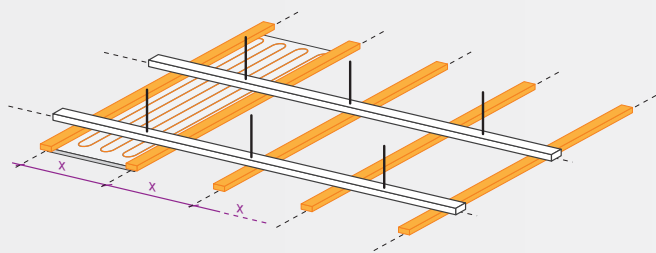

Cross joists longitudinal to the ModulePanels

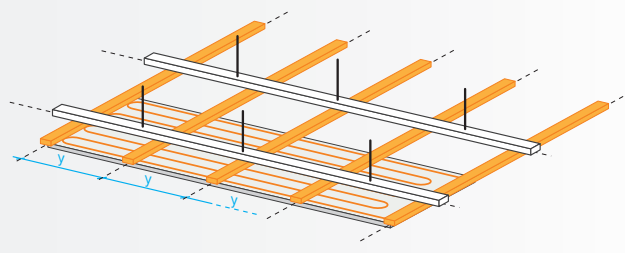

Cross joists transverse to the ModulePanels

Panel size h × w [mm]	ModulePanels-Classic									-Acoustic 1000 × 625
	2500 × 625	2500 × 600	2000 × 625	2000 × 600	1500 × 625	1500 × 600	1000 × 625	1000 × 600	2000 × 312	
Max. axis clearance [mm] longitudinal cross joists (x)	625	600	625	600	625	600	625	600	312	625
Max. axis clearance [mm] transverse cross joists (y)	416.7	416.7	500	500	375	375	500	500	500	500

🔥 In the case of fire protection requirements, except where test verification/certification is otherwise specified

3.5 Directly fastened cross joists (variant without main joists)

Due to the low construction height it is necessary to interrupt the substructure approx. 200 mm after the end of the panel. This is followed by an intermediate space of 200 mm for supply lines and/or press connections of the ModulePanels.

For axis clearances of the cross joists, see Section 3.4.

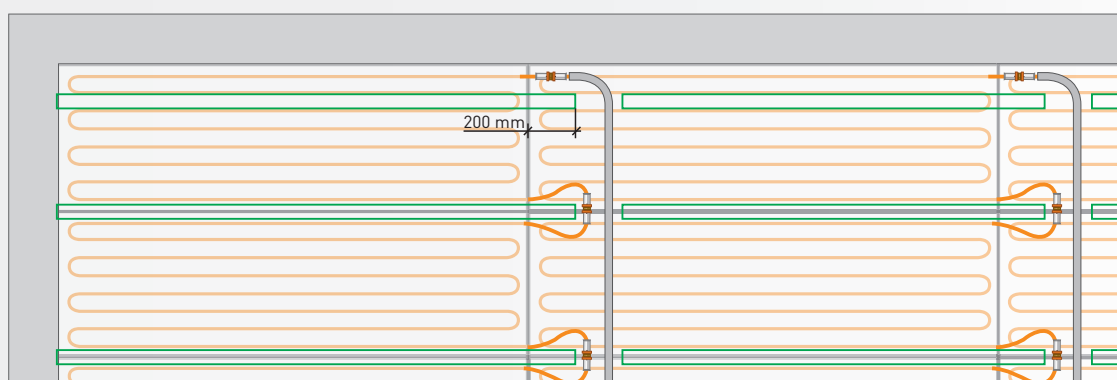

4.1 ModulePanels-Acoustic – Overview

ModulePanels with different sized holes to improve the acoustic characteristics.

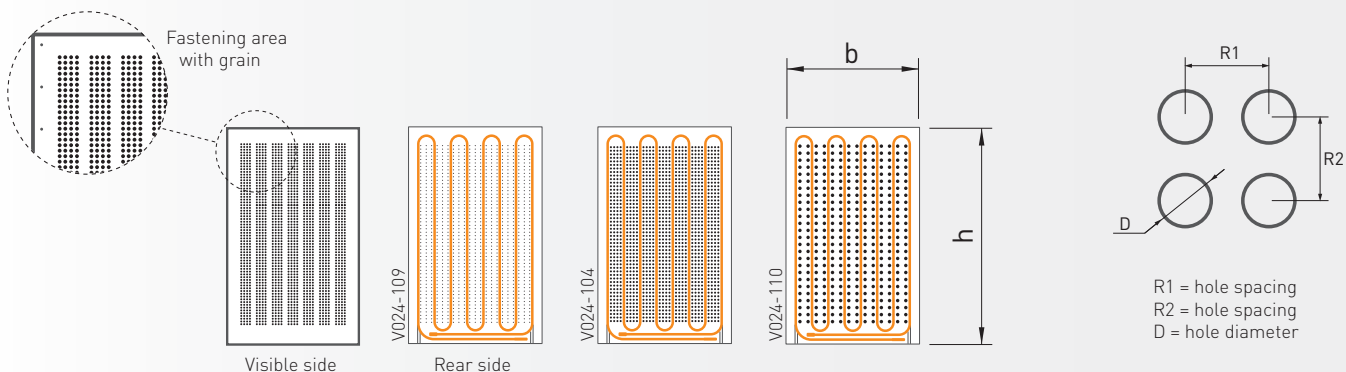

Part no.	Colour code	Product code	h [mm]	b [mm]	A [m ²]	D [mm]	R1 [mm]	R2 [mm]	Heating/cooling area A _{HK} [m ²]	Weight/Panel	Required quantity ¹⁾ dry wall screws (3.9 × 40 mm)	
											Longitudinal joists	Transverse joists
V024-109		MSDA-1000-625-F06	1000	625	0.63	6	25.0	16.0	0.63	11.6 kg	2 × 5 pcs.	3 × 3 pcs.
V024-104		MSDA-1000-625-B08	1000	625	0.63	8	15.0	16.0	0.63	10.5 kg	2 × 5 pcs.	3 × 3 pcs.
V024-110		MSDA-1000-625-F12	1000	625	0.63	12	37.5	32.0	0.63	11.4 kg	2 × 5 pcs.	3 × 3 pcs.

¹⁾ Spread out bolts evenly across the length/width of the panel

4.2 ModulePanels-Acoustic – Fastening area

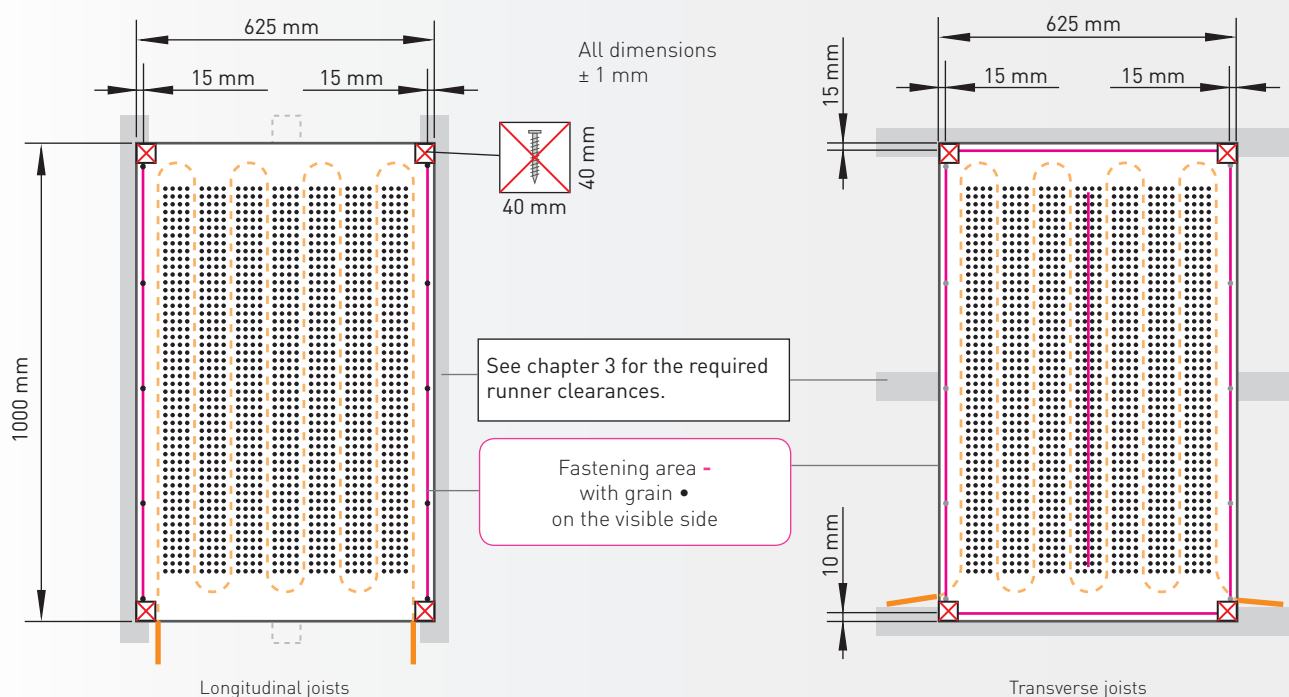

4.3 ModulePanels-Classic – Overview

Fixed and variable ModulePanels have been developed to accommodate the different local conditions on building sites.

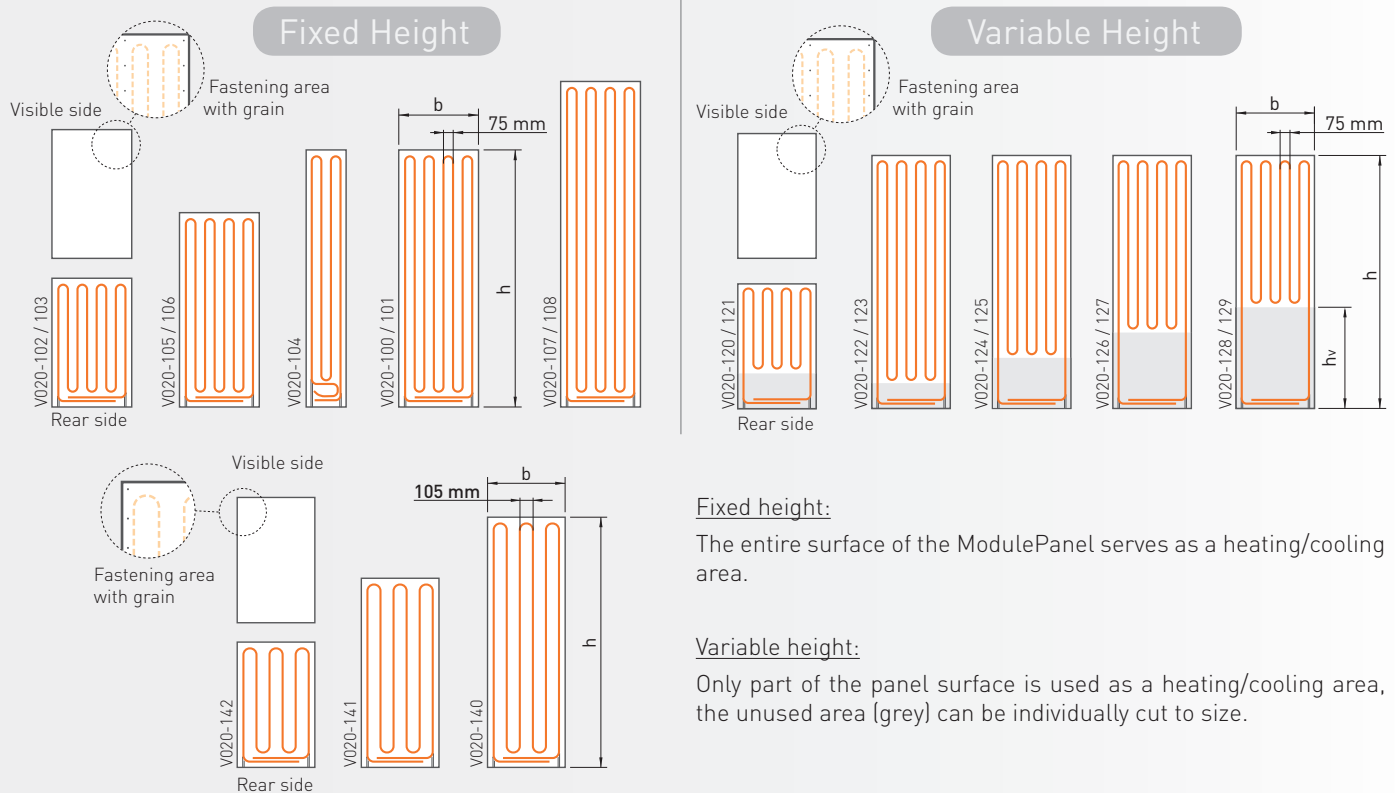

Fixed height:

The entire surface of the ModulePanel serves as a heating/cooling area.

Variable height:

Only part of the panel surface is used as a heating/cooling area, the unused area (grey) can be individually cut to size.

Part no.	Colour code on the ModulePanel	Product code	h [mm]	b [mm]	A [m ²]	Pipe spacing [mm]	Height h _v [mm]	Heating/cooling area A _{HK} [m ²]	Weight/Panel	Required quantity ¹⁾ dry wall screws (3.9 x 40 mm)	
										Longitudinal joists	Transverse joists
V020-100		MDC-2000-625	2000	625	1.25	75	-	1.25	25.5 kg		
V020-101		MDC-2000-600	2000	600	1.20	75	-	1.20	24.5 kg	2 x 9 pcs. / 3 x 11 pcs. 🔥	5 x 5 pcs. / 6 x 5 pcs. 🔥
V020-140		MDC-2000-625-105	2000	625	1.25	105	-	1.25	25.6 kg		
V020-102		MDC-1000-625	1000	625	0.63	75	-	0.63	12.8 kg		
V020-103		MDC-1000-600	1000	600	0.60	75	-	0.60	12.2 kg	2 x 5 pcs. / 3 x 6 pcs. 🔥	3 x 3 pcs. / 4 x 5 pcs. 🔥
V020-142		MDC-1000-625-105	1000	625	0.63	105	-	0.63	12.9 kg		
V020-104		MDC-2000-312	2000	312	0.62	75	-	0.62	12.6 kg	2 x 9 pcs. / 2 x 11 pcs. 🔥	5 x 2 pcs. / 6 x 3 pcs. 🔥
V020-105		MDC-1500-625	1500	625	0.94	75	-	0.94	19.2 kg		
V020-106		MDC-1500-600	1500	600	0.90	75	-	0.90	18.4 kg	2 x 7 pcs. / 3 x 9 pcs. 🔥	5 x 3 pcs. / 5 x 5 pcs. 🔥
V020-141		MDC-1500-625-105	1500	625	0.94	105	-	0.94	19.2 kg		
V020-107		MDC-2500-625	2500	625	1.56	75	-	1.56	33.8 kg	2 x 11 pcs. / 3 x 14 pcs. 🔥	7 x 3 pcs. / 7 x 5 pcs. 🔥
V020-108		MDC-2500-600	2500	600	1.50	75	-	1.50	30.6 kg		
V020-120		MDC-1000-625-V300	1000	625	0.63	75	300	0.48	13.0 kg	2 x 5 pcs. / 3 x 6 pcs. 🔥	3 x 3 pcs. / 4 x 5 pcs. 🔥
V020-121		MDC-1000-600-V300	1000	600	0.60	75	300	0.46	12.5 kg		
V020-122		MDC-2000-625-V200	2000	625	1.25	75	200	1.17	25.7 kg		
V020-123		MDC-2000-600-V200	2000	600	1.20	75	200	1.12	24.6 kg		
V020-124		MDC-2000-625-V400	2000	625	1.25	75	400	1.04	25.8 kg		
V020-125		MDC-2000-600-V400	2000	600	1.20	75	400	1.00	24.8 kg		
V020-126		MDC-2000-625-V600	2000	625	1.25	75	600	0.92	26.0 kg	2 x 9 pcs. / 3 x 11 pcs. 🔥	5 x 5 pcs. / 6 x 5 pcs. 🔥
V020-127		MDC-2000-600-V600	2000	600	1.20	75	600	0.88	24.9 kg		
V020-128		MDC-2000-625-V800	2000	625	1.25	75	800	0.79	26.2 kg		
V020-129		MDC-2000-600-V800	2000	600	1.20	75	800	0.76	25.1 kg		

🔥 In the case of fire protection requirements, except where test verification/certification is otherwise specified

¹⁾ Spread out bolts evenly across the length/width of the panel

4.4 ModulePanels-Classic – Fastening area

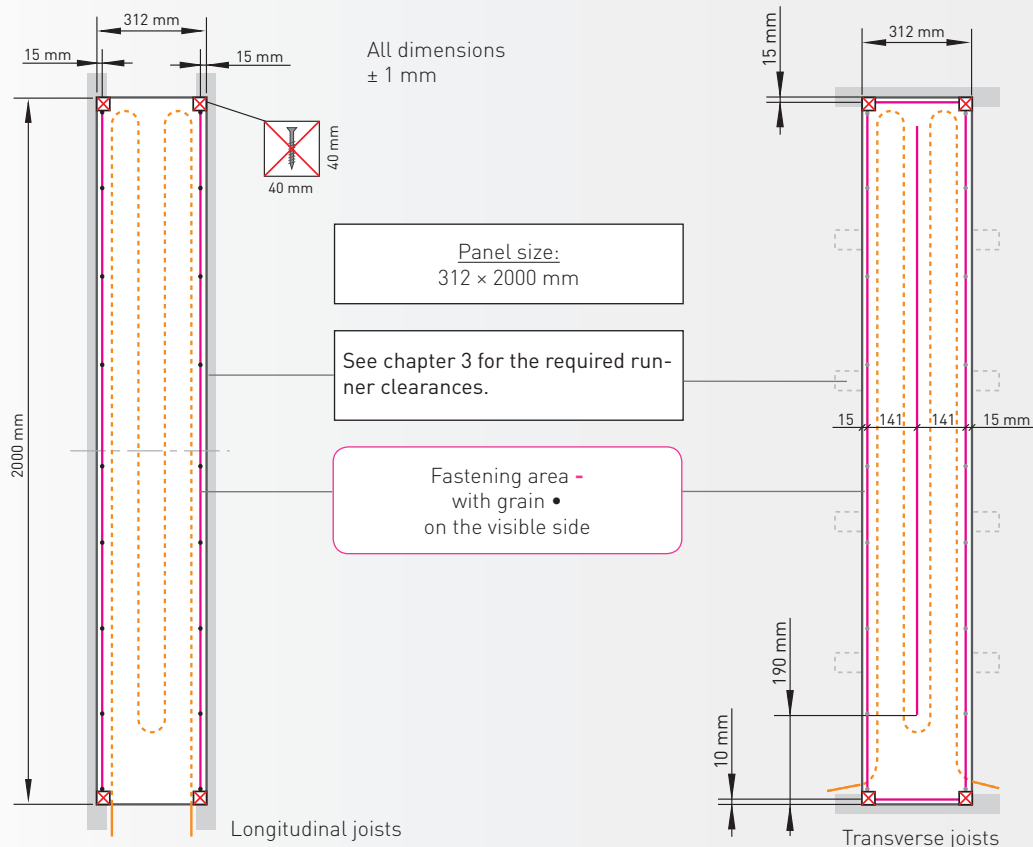
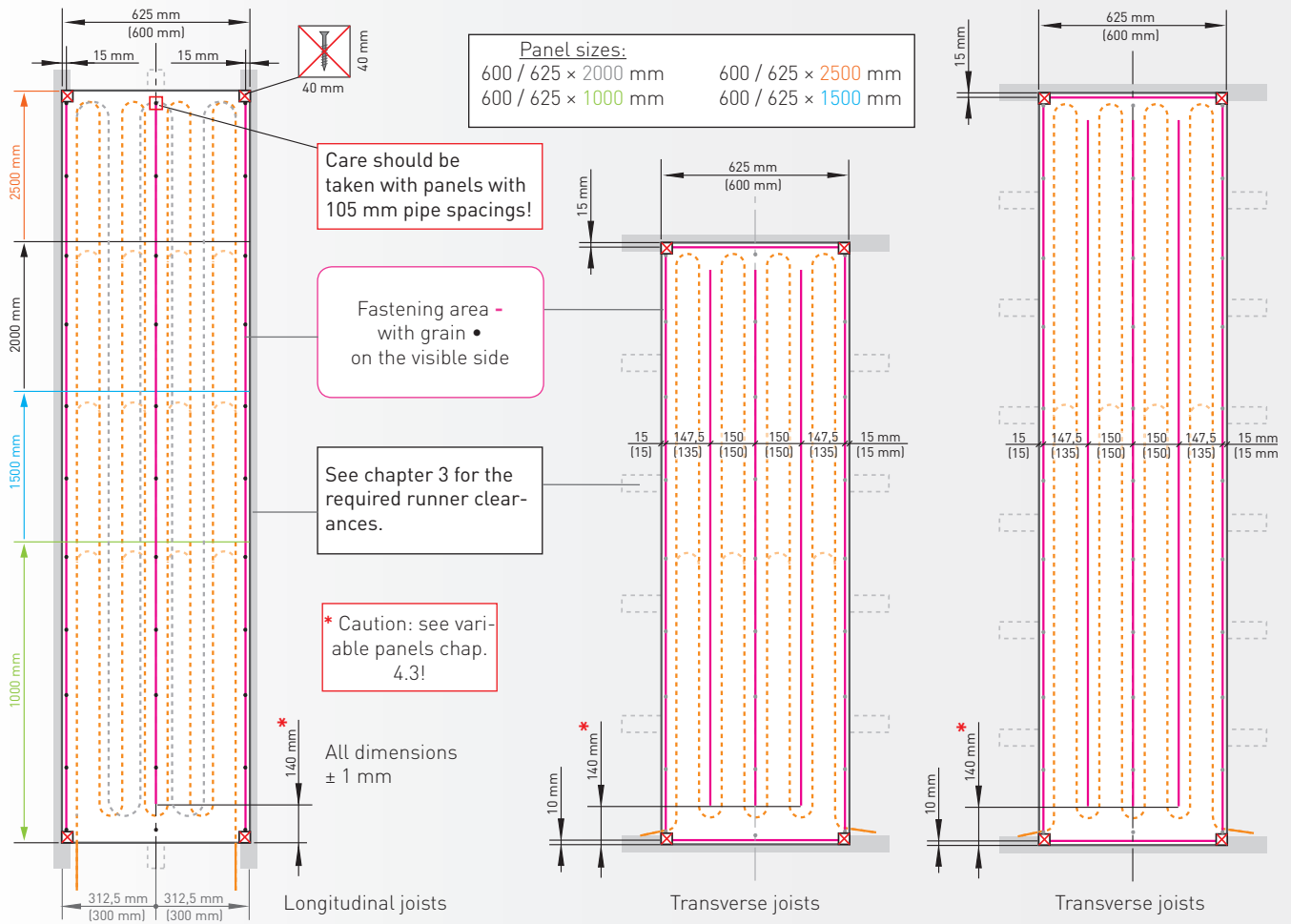

4.5 Installing the ModulePanels

1 Fold out the pipe:

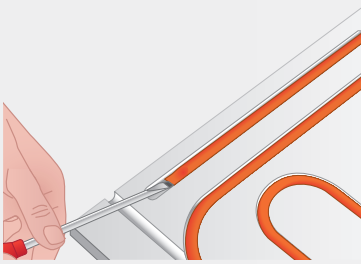

Move the Variomodular pipe out of its „parking position“...

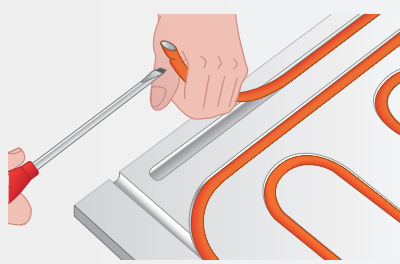

....

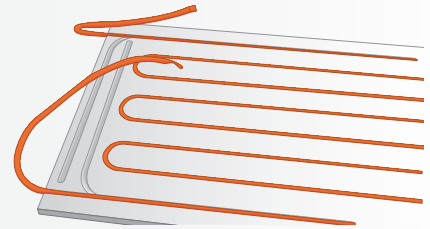

... and insert it into the groove along the long side of the panel.

2 Preparing ModulePanels (if required):

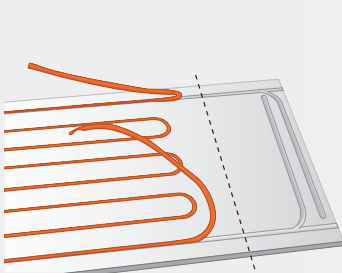

Cut the (variable) ModulePanel straight (preferably using a circular saw with a vacuum attachment).

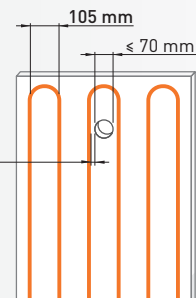
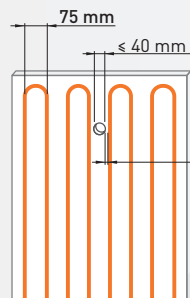
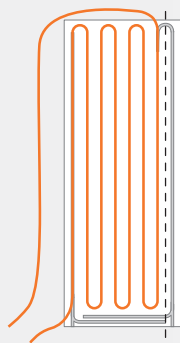

Clearance to the pipe ≥ 10 mm

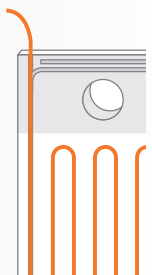

If necessary, drill a hole, for example, ducting or light spots.

3 Install the first panel:

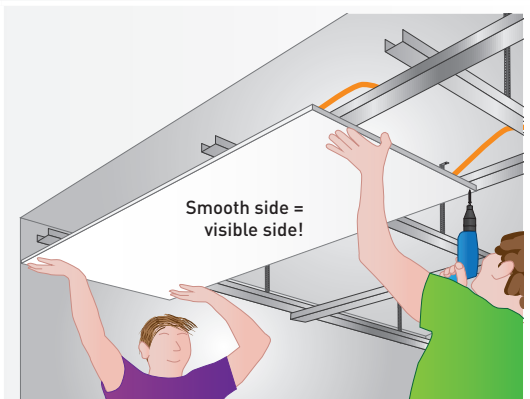
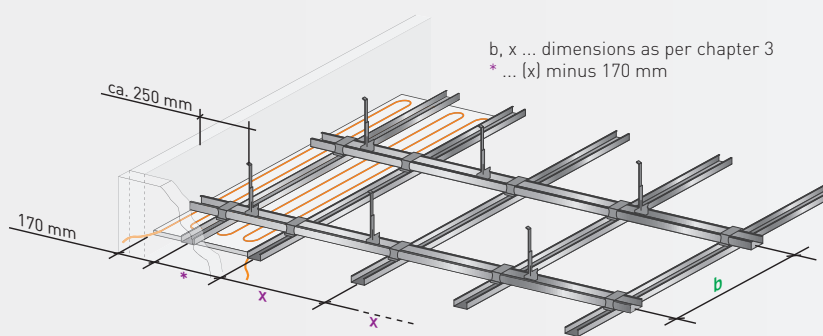

Caution: Pay attention to the Variomodular pipe with substructures in edge areas! (Fastening outside the fastening area).

The ModulePanel is installed in the fastening area (see section 4.2 or 4.4) using Variotherm dry wall screws (3.9 x 40 mm) or staples. **Tip from Variotherm:** Use a power screw gun if possible and set the penetration depth of the screw head to approx. 1 mm.

Observe the order of the fastening points! >>

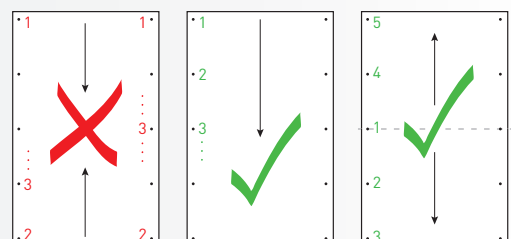

4 Apply joint adhesive:

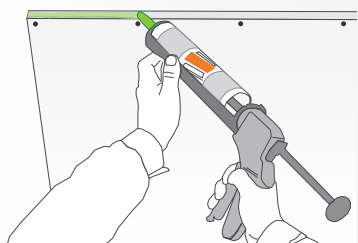

The joint adhesive from the cartridge is applied as a flat bulge along the entire dust-free vertical edge of the panel. The working temperature of the adhesive should be greater than 10 °C and the room temperature should be greater than 5 °C.

A tip from Variotherm: Cut off the cartridge tip as shown in the illustration. >>



5 Installation of the other ModulePanels (max. 6.25 m² heating/cooling surface area per heating/cooling circuit):

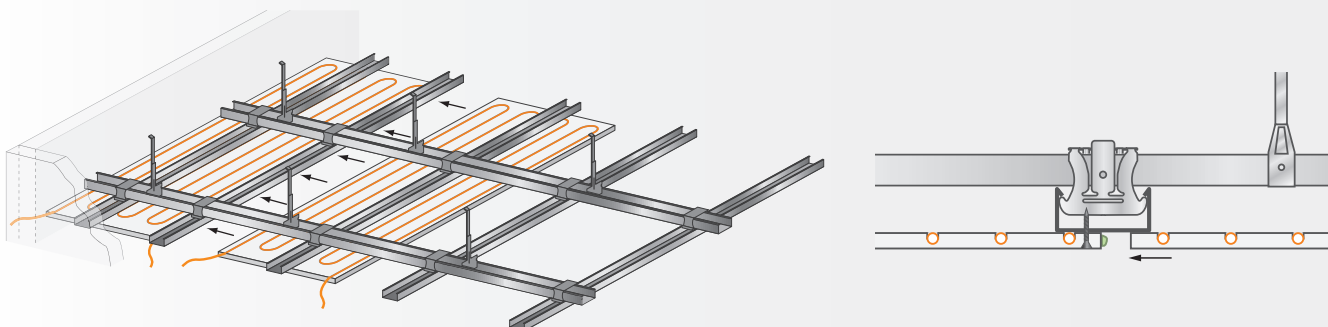

The next ModulePanel is thus pressed against the already installed ModulePanel, resulting in a seam with a maximum width of 1.0 mm (visual inspection!). Then screw the ModulePanel in place as specified (see chap. 4.1 to 4.4)

Do not remove soft joint adhesive; leave it to set for approximately 18 to 36 hours (set adhesive will be scraped off later – see section 5.1).

Check the abutting seam of the panels:

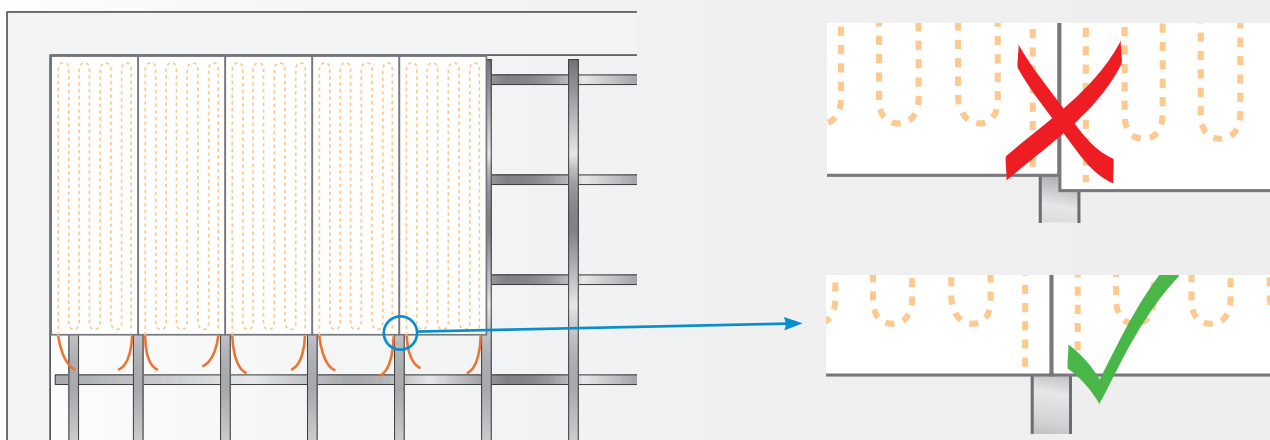

4.6 Movement joints

Movement joints are to be provided every 8 m in ceiling constructions.

Caution: Pay special attention to the Variomodular pipes when fastening the ModulePanels in the area of the movement joints (deviation from fastening area)!

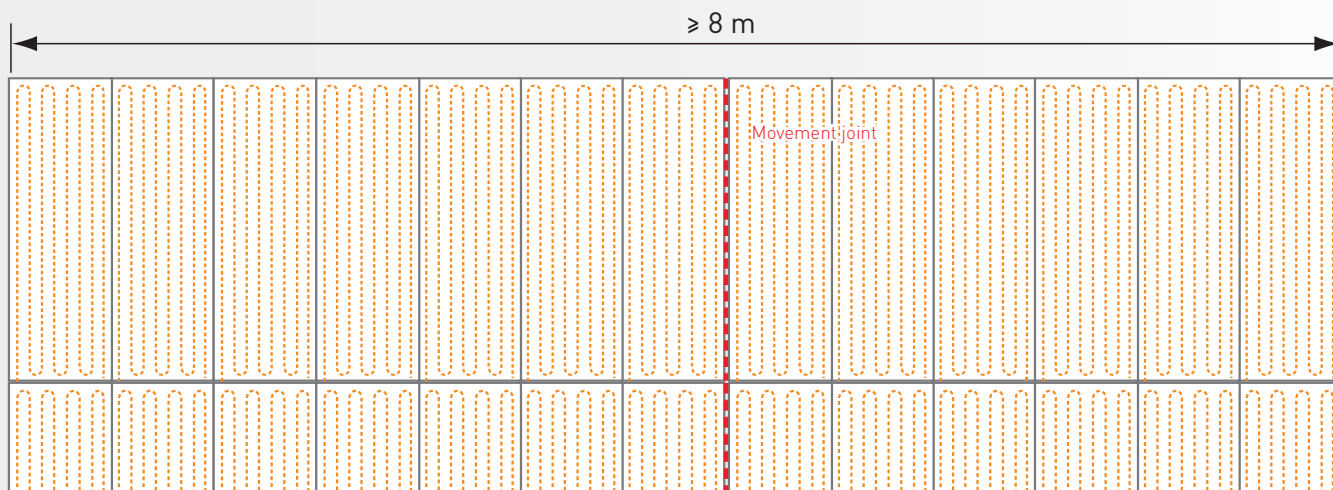

Movement joint at [e.g.] 13 × V020-100 (13 × 0.625 m = 8.13 m)

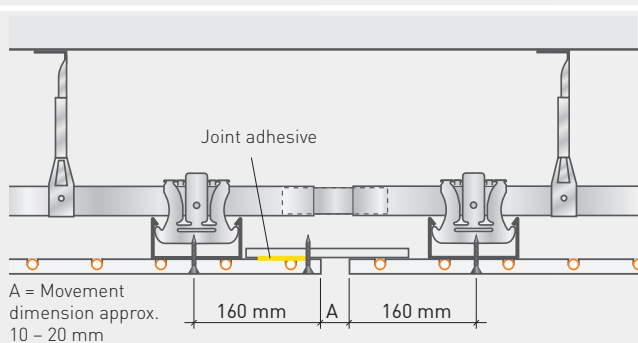

Movement joint with panel strip

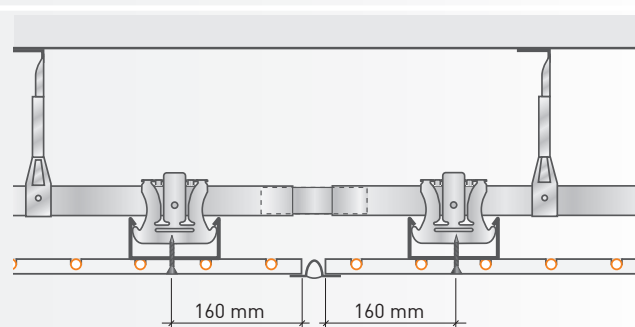

Movement joint with additional profile

4.7 Fitting dew-point controller

The dew-point sensor is fitted with e.g. cable ties at the position on the pipe that is expected to dew first. Generally this is the case at the flow entry.

Make sure that there is good thermal contact between the pipe and the sensor (use heat transfer paste).

The supply pipes should be sufficiently secured.

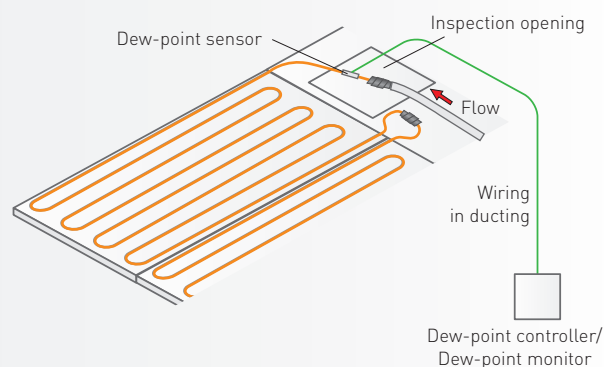

Example of modular ceiling cooling >>

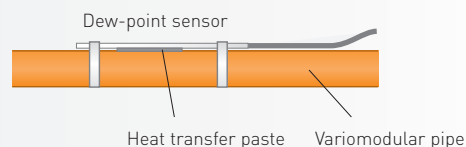

4.8 ModuleExpansionPanels

The areas at the sides of or above the ModulePanels are filled out using ModuleExpansionPanels with offset seams (please observe the FERMACELL guidelines). The ModuleExpansionPanels are also glued with joint adhesive on the front side. >>

Cut panel edges (circular saw) must always be cleaned of all dust immediately before applying the joint adhesive.

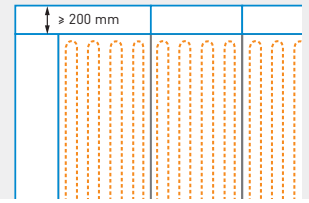

4.9 Panel transitions

Connections to walls or pitched roofs are to be constructed as drywall seams (approx. 7 mm) ■ with a separating layer ■ or using angled beading (decoupled connections).

Caution: Pay special attention to the Variomodular pipes when fastening the ModulePanels in the connection areas (deviation from fastening area)!

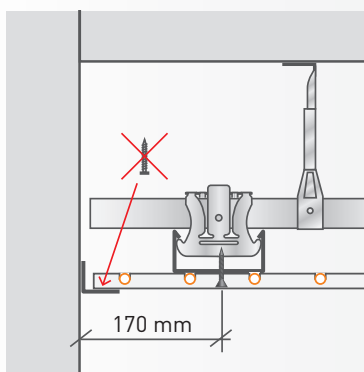

Connection with angled beading

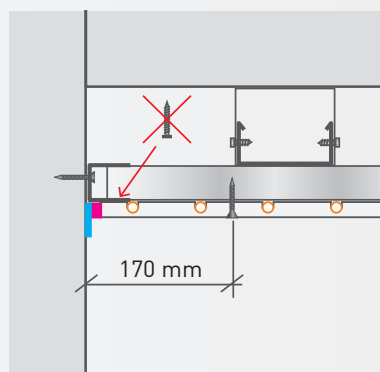

Connection with UD profile –
Cross joists transverse to the panel

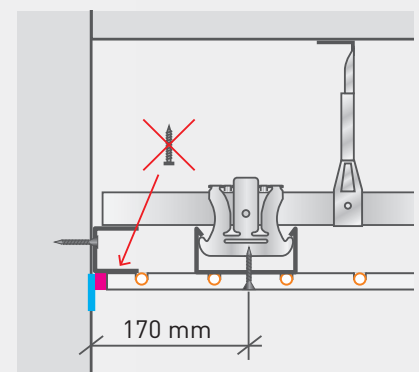

Connection with UD profile –
Cross joists longitudinal to the panel

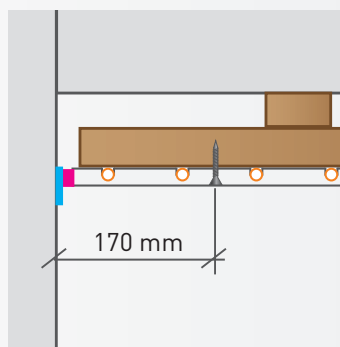

Connection with separating layer

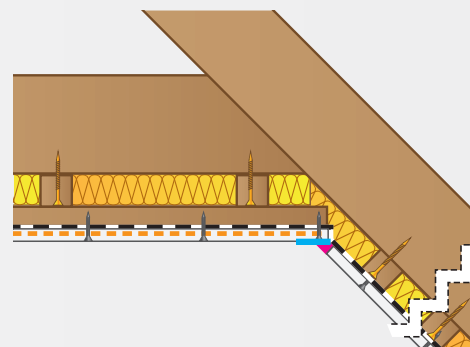

ModuleCeiling to roof pitch

4.10 Transitions from ModulePanels to other panel materials

Variotherm provides no guarantee for transitions to panel materials (e.g. plasterboard panels).

Please observe the specifications of the respective (panel) manufacturer.

We can, however, provide you with the following practical examples of transition methods:

- Grouted joints (approx. 7 mm) ■ with a separating layer ■ (decoupled connection). Advantage: intentional straight crack (usually hardly visible)
- Elastic seam (acrylic mass), (maintenance seam, not suitable for fire prevention constructions)
- Fascia
- Wooden strip fastened on one side for covering the transition

4.11 Installation of panels between installed ModulePanels

If "drop to drop" installation of the ModulePanels is not possible, proceed as follows:

- 1 Glue one side of the Modular Expansion Panel using joint adhesive
- 2 Leave a 3 to 8 mm gap on the other side.
- 3 Completely fill the gap with **Variotherm Duo adhesive** (special **W048 manual applicator** required!).

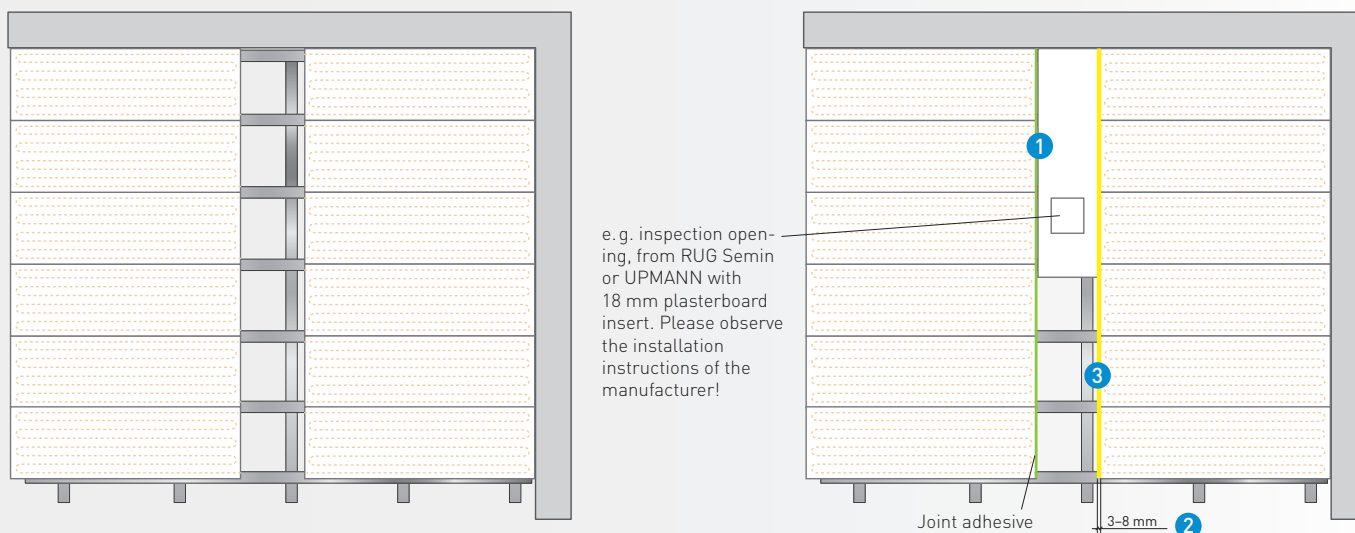

Processing:

- The surfaces of the ModulePanels must be clean, dry, dust-free and grease-free.
- Open the cartridge – screw on the static mixing tube.
- Insert the cartridge into the Duo manual applicator.
- For safety reasons, do not use the first amount of mixed adhesive for gluing (20 g, approx. walnut-sized).
- Completely fill the joint from the top to the bottom using the static mixing tube.
- For a better filling result, use a pointing trowel (or similar) to slightly hollow out the fresh joint.
- Remove excess adhesive when still fresh. Hardened adhesive can only be removed with great effort.
- The static mixing tube remains on the cartridge unit at the end of work/during breaks – the static mixing tube is then replaced the next time work begins again.
- The joint can be covered with filler 4 hours after gluing the panels (working temperature > +15 °C).



Duo adhesive

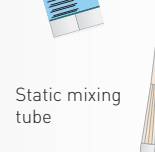

Static mixing tube



Manual applicator

Safety information:

Keep out of the reach of children! For further information see the product label or the safety data sheets according to Regulation 1907/2006/EC, Annex II, available at www.variotherm.com/en/service/info-centre/safety-data-sheets.html.

Wear suitable protective gloves. Protect your skin, eyes, clothing and tools from coming into contact with unhardened Duo adhesive. In the case of skin contact clean immediately with soap and water. Clean contaminated tools immediately with universal thinner. Hardened adhesive can only be removed mechanically.

Technical data:

Basis:	2-component PUR reaction adhesive
Colour when hard:	beige
Viscosity at +20 °C:	low-viscosity paste
Working time (at +10/+20/+30 °C):	approx. 60/30/15 minutes
Hardening time (+20 °C, 50 % relative humidity):	approx. 24 hours, final hardness after approx. 7 days
Working temperature:	minimum of +7 °C to a maximum of +30 °C
Net weight:	900 g (2 × 310 ml tandem cartridge)
Usage:	1 cartridge is sufficient for an approx. 7 m joint (with a breadth of 4 mm and a height of 18 mm)
Storage:	unopened, in a dry place at +15 °C to +25 °C approx. 15 months

4.12 Ceiling elements

Caution: Pay special attention to the Variomodular pipes when fastening the Modular Panels in the edge area (deviation from fastening area)!

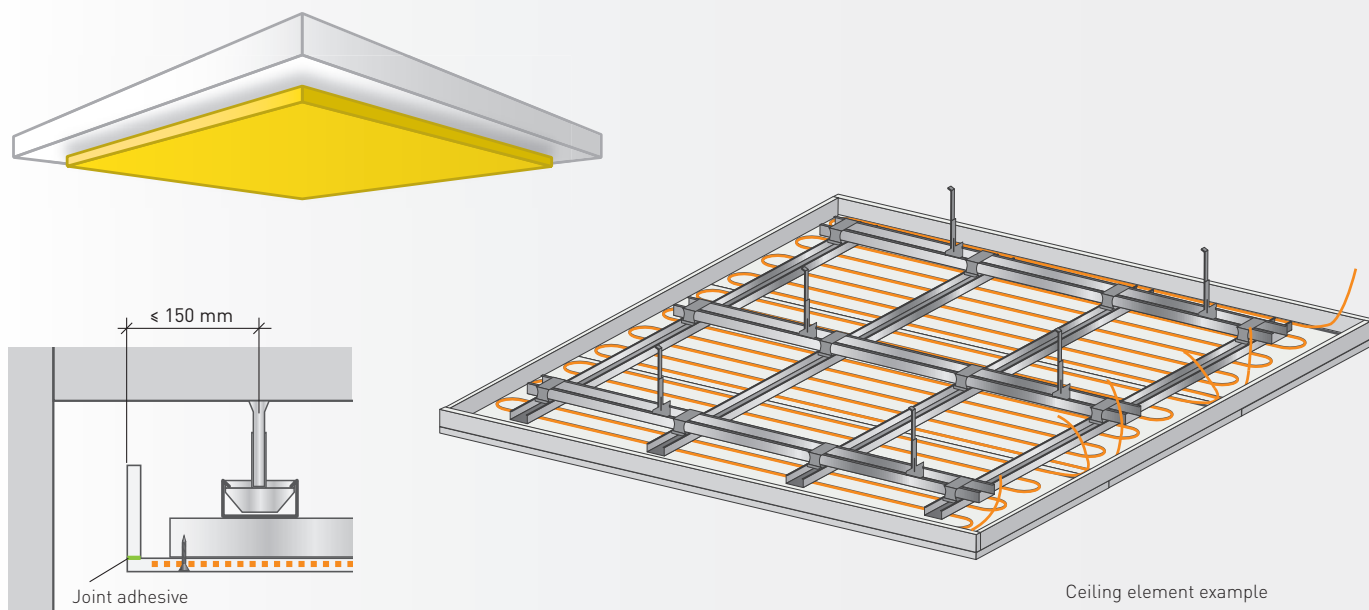

4.13 Insulation with ModulePanels-Acoustic

With ModulePanels-Acoustic the hollow space in the ceiling construction is laid with mineral wool (e.g. Rockwool Sonorock or equivalent). Vapour-retarders cannot be installed. Care must be taken to ensure that the dew point is not reached within the mineral wool.

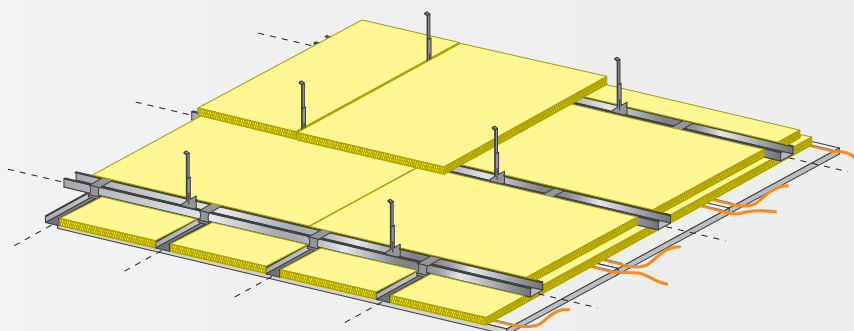

Example of substructure insulation

4.14 Hydraulic connection & pressing

ModulePanel connection options:

Maximum heating/cooling surface area per circuit: 6.25 m² (e.g. 5 × V020-100)

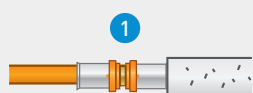
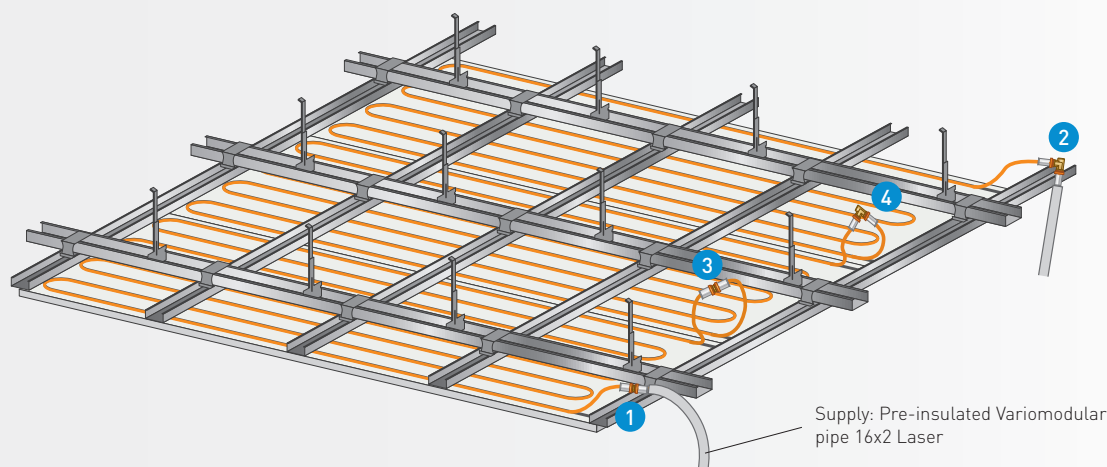

Press-fit coupling 16x11.6

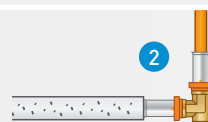

Press-fit angled coupling 90° 16x11.6



Press-fit coupling 11.6x11.6

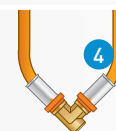

Press-fit angled coupling 90° 11.6x11.6

Corrosion prevention notice:

The connecting elements are to be protected (after the pressure test) in accordance with ÖN H 5155. For example, using cold shrink tape or corrosion protection tape. This measure is also a prerequisite for effective dew-point monitoring.



Once the panels and the heating/cooling manifolds are installed, the panels are connected to the desired circuits. The pre-insulated Variomodular pipe 16x2 is used as the supply pipe. If modified insulation thicknesses are necessary (e.g. for cooling), these must be provided by the customer (see also section 1). Ensure air-tightness – glue insulation joints air-tight.

Caution! A lasting, tight connection is only guaranteed if original Variotherm system components are used:

- Pre-insulated Variomodular pipe 16x2 Laser or Variomodular pipe 11.6x1.5 Laser
- Variotherm calibration and chamfering tool
- Variotherm press-fit coupling and Variotherm pressing tool

Maintenance

The press-fitting jaws and pressing tool must be checked at least once a year for correct operation by REMS or an authorised REMS customer service workshop.

Preparing the pipe:



Pressing procedure for AkkuPress:



- Push the press-fitting jaws (Z) together by hand (causing the press-fitting jaws to open) far enough so that the press-fitting jaws can be placed over the press-fit coupling ②. Place the pressing tool with press-fitting jaws on the press-fit coupling at a right angle to the pipe axis.
- Release the press-fitting jaws so that they close around the press-fit coupling ③.
- Hold the pressing tool at the housing grip (G) and at the motor grip (M). When using an REMS AkkuPress, hold the switch (S) pressed until the press-fitting jaws are fully closed. This is indicated by an audible click.
- Press the reset lever (R) until the pressing rollers (P) have retracted completely. Press the press-fitting jaws (Z) together by hand so that the jaws can be removed from the press-fit coupling (see also the REMS AkkuPress operating manual).

The following situations must be avoided (danger of gearbox breakage!):

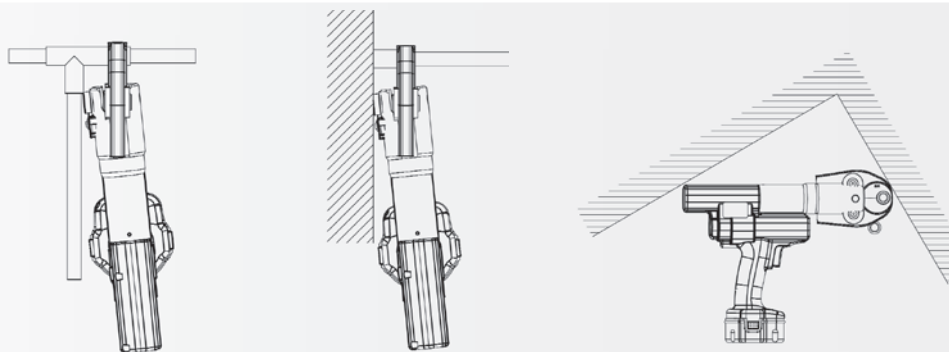

Pressing procedure for EcoPress:

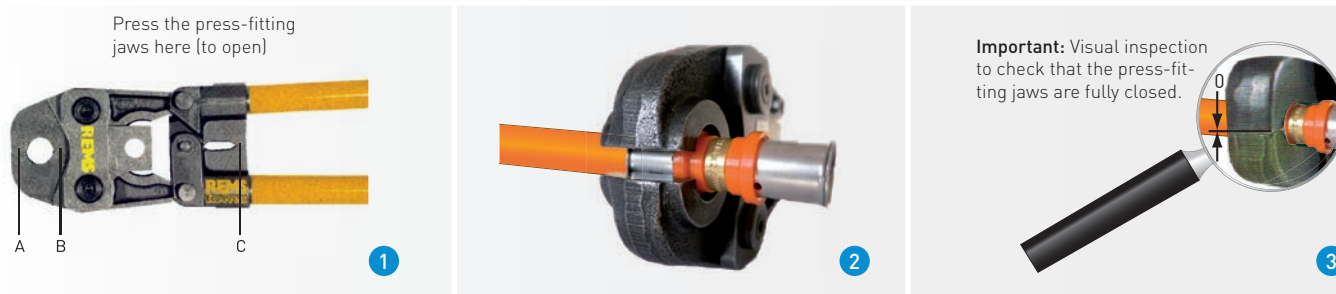

- The pressing tool's lever length can be adjusted to suit the pressing force and the available space on site. Use the provided pipe arms with sleeve sockets for extension. Always screw pipe arms tight before use (danger of accidents!). Secure the selected press-fitting jaws with plug-in bolts.
- Pull the pipe arms far enough apart (press-fitting jaws open) so that the press-fitting jaws can be slid over the press-fit coupling ②. Place the press-fitting jaws on the press-fit coupling at a right angle to the pipe axis.
- Push pipe arms together until they reach the stop position (C) (a click is heard when they reach the stop). Only if the press-fitting jaws are fully closed at (A) and at (B) has a correct press connection been carried out. > Visual check ③.
- Re-open the pipe arms so that the jaws can be removed from the press-fit coupling (see also the REMS EcoPress operating manual).

5.1 Stopping

After installation, the ModulePanels and the Modular Expansion Panels are stopped using FERMACELL grouting or fine stopper. However, before this happens the set joint adhesive must be fully scraped off (the joint adhesive hardens after approx. 18 to 36 hours, depending on the room temperature). Attempting to remove joint adhesive that is still soft will result in smearing.

Caution: Stopping must not be performed until all wet work has dried out (wet screed, plastering work etc.)!

- Scrape off the joint adhesive, e.g. using an adhesive scraper or wooden chisel
- Stop the seam area and recessed fasteners using FERMACELL grouting (Q1)

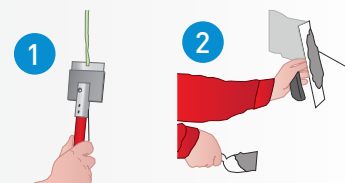

The following work is to be performed, depending on the surface quality required:

Q1	• Stopping of visible joints and adhesive seams with FERMACELL grouting
Q2	• Q1 + burr-free and step-free stopping of the seams and joints
	<u>Full-surface stopping:</u>
Q3	• Stopping of the visible joints with FERMACELL grouting or plaster • Wide stopping of the seams • Full-surface coating and sharp pulling-off using FERMACELL grouting or fine stopper or other suitable stopping material
	<u>Full-surface coating:</u>
Q4	• Stopping of the visible joints with FERMACELL grouting or plaster • Wide stopping of the seams • Full-surface coating and smoothing using FERMACELL fine stopper or plaster or other suitable stopping material

5.2 Fastening loads to the ModuleCeiling

Low “static” loads can be fixed directly on the ModuleCeiling as prescribed by the following table:

Caution: Do not damage the Variomodular pipes!

Fixing components - Observe the instructions of the dowel manufacturer!	Permissible single loads for individual hanging on ModulePanel (dowel distance \geq 300 mm)	Max. permissible area load per m ² ModulePanel (dowel distance \geq 300 mm)
	2 kg	6 kg

Heavier suspended elements must only be attached to the substructure and not to the ModulePanels. Additional loads must be designed for the substructure (see max. permissible span, chapter 3).

5.3 Painting

Commonly available paints such as (e.g.) latex, emulsion or enamel paint can be applied to the ModulePanels. Mineral-based paints such as (e.g.) lime wash and silicate paints must be approved by the manufacturer for use on gypsum fibreboards. The paint is usually applied in two steps.



Details regarding the system and heating circuit pipes and the room temperature control are provided in the **DISTRIBUTION and CONTROL** design and installation manual.

Construction project: _____

Building owner/Occupant: _____

Client: _____

Heating installation technician: _____

Architect: _____

Other: _____

6.1 Leak-tightness test

After installation and before completion work (plastering, painting, wallpapering), the circuits of the Variotherm ModuleCeiling are to be checked for leak-tightness via a water pressure test. The test pressure should be min. 4 bar and max. 6 bar. If there is a risk of freezing, appropriate measures should be taken, e. g. use of antifreeze and controlling the building's temperature.

- Installation of ModulePanels finished on: _____
- Installation of pipe connections finished on: _____
- Pressure test started on: _____ with test pressure ____ bar
- Pressure test finished on: _____ with test pressure ____ bar
- Start of completion work (plastering, painting, wallpapering) on: _____
- System pressure during the completion work was ____ bar
- The system water was treated (e. g. per ÖNORM H 5195-1) Yes No
- Antifreeze was added to the system water Yes No
- The system was checked for leak-tightness on: _____ and approved

Approval:

Building owner/Occupant/Client

Construction management/Architect

Heating installation technician

6.2 Preheating Protocol

Preheating of the Variotherm ModuleCeiling

- Completion work finished on: _____
- Preheating started on: _____
- Supply temperature set to 23–30 °C and retained for 1 day completed
- Increase to a supply temperature of 30–40 °C and maintained for ½ day completed
- Set to maximum calculated supply temperature plus 5 °C
[Caution: The maximum supply temperature of the ModuleCeiling is: 50 °C] completed
- Maintained for ½ day, set falling supply temperature to 30 °C, maintain for 1 day completed
- Heating switched off on: _____
- Operating state and outdoor temperature on handover:

Approval:

Building owner/Occupant/Client

Construction management/Architect

Heating installation technician

ENJOY THE COMFORT AND SAVE ENERGY

That's why our customers love us:

Heating and cooling optimised for COMFORT in all rooms!

Fast and friendly service, ANSWERS backed up with expertise!

Always in tune with the latest technology, INNOVATION guaranteed!

Everything CLEAR and SIMPLE, in writing of course!

PROFESSIONALISM at all times, from the first contact to the reference list!

VARIOTHERM SINCE 1979

Variotherm is an Austrian model plant with hundreds of partners in Austria, Europe and around the world.

All rights pertaining to distribution and translation, in whole or in part, including film, radio, television, video recording, Internet, photocopying and reprinting, are reserved. Subject to mistakes and printing errors.



VARIOTHERM HEIZSYSTEME GMBH

GÜNSELSDORFER STRASSE 3A
2544 LEOBERSDORF
AUSTRIA

Phone: 0043 22 56 - 648 70-0

Fax: 0043 22 56 - 648 70-9

office@variotherm.com www.variotherm.com